



New South Wales

Road Transport (Vehicle Registration) Regulation 2017

under the

Road Transport Act 2013

His Excellency the Governor, with the advice of the Executive Council, has made the following Regulation under the *Road Transport Act 2013*.

MELINDA PAVEY, MP
Minister for Roads, Maritime and Freight

Explanatory note

The object of this Regulation is to remake, with some changes, the *Road Transport (Vehicle Registration) Regulation 2007*, which is repealed on 1 September 2017 by section 10 (2) of the *Subordinate Legislation Act 1989*.

This regulation makes provision with respect to the following matters under Chapter 4 of, and Schedule 2 to, the *Road Transport Act 2013*:

- (a) the process for registering registrable vehicles,
- (b) the alteration of vehicles' registration status,
- (c) the circumstances in which the use of unregistered registrable vehicles is authorised or permitted,
- (d) the vehicle standards with which registrable vehicles must comply in order to be used on roads or road related areas,
- (e) the certification of registrable vehicles as complying with the applicable vehicle standards,
- (f) written-off vehicles,
- (g) vehicles to which Chapter 4 of the *Road Transport Act 2013*, and the registration provisions of this Regulation, do not apply,
- (h) fees for services in connection with the registration of vehicles,
- (i) the registration charges for chargeable heavy vehicles,
- (j) other miscellaneous matters.

This Regulation is made under the *Road Transport Act 2013*, including Chapter 2, sections 63, 64 (1) and (3), 66 (1) and (4), 68 (2), 70 (2), 71, 76 (4) and (5), 79 (6) and (7), 81 (b), 82, 83 (3) (f), 85 (1) (b) and (c), 90 (1) (a), 91 (b), 93 (1)–(3), 94 (1) (a), 97 (1), 98 (1) (b), 103, 135 (1), Part 2 of Schedule 1 and clause 2 of Schedule 2.

This Regulation comprises or relates to matters set out in Schedule 3 to the *Subordinate Legislation Act 1989*, namely matters of a machinery nature and matters arising under legislation that is substantially uniform or complementary with legislation of the Commonwealth or another State or Territory.

Contents

	Page
Part 1 Preliminary	
1 Name of Regulation	8
2 Commencement	8
3 Definitions	8
4 Applications through agents	8
Part 2 Registration process	
Division 1 Eligibility for registration	
5 Persons eligible to be registered operators of registrable vehicles	9
6 Registrable vehicles eligible to be registered	9
Division 2 Applications for registration	
7 Persons eligible to be registered operators may apply for registration	9
8 Form of application	9
9 Supporting evidence	10
10 Lodgment of application, supporting evidence and payment	10
11 Duration of registration	11
12 Determination of applications	11
13 Conditional registration	12
Division 3 The Register	
14 Maintenance of the Register	12
Division 4 Registration documents	
15 Certificates of registration	14
16 Registration labels for certain registrable vehicles	14
17 Replacement of registration documents	15
Division 5 Number-plates	
Subdivision 1 Interpretation	
18 Definition	15
19 Application of Division to trader's plates	16
Subdivision 2 Issue of number-plates	
20 Number-plates generally	16
21 Special number-plates	16
22 Auxiliary number-plates	17
23 Authority may alter distinguishing number of registration	18
24 Authority may alter number-plate design	18
Subdivision 3 Use of number-plates	
25 Display of number-plates	18
Subdivision 4 Reservation, transfer and replacement of number-plates	
26 Reservation of number-plates	21
27 Transfer of number-plates	21

	Page
28 Replacement of surrendered number-plates	21
Subdivision 5 Damaged, destroyed or missing number-plates	
29 Damaged number-plates	22
30 Lost, stolen or destroyed number-plates	22
31 Recovery of lost or stolen number-plates	22
Subdivision 6 General	
32 Return of number-plates	23
33 Special number-plate concession arrangements	23
34 Possession of number-plates	23
Division 6 Renewal of registration	
35 Notices of renewal of registration	24
36 Renewal of registration	24
Part 3 Alteration of registration status	
Division 1 General obligations of registered operators	
37 Obligations of registered operators	26
Division 2 Transfer of registration	
38 Obligations of disposers: application for transfer of registration and notification to Authority	26
39 Obligations of acquirers	27
40 Repossession and restoration	28
41 Registration of the transfer of vehicles and functions of the Authority	28
42 Transfer on death of registered operator	29
Division 3 Expiry of registration	
43 Expiry of registration	29
Division 4 Surrender, suspension and cancellation of registration	
44 Surrender of registration by registered operator	30
45 Suspension or cancellation of registration by Authority	30
46 Suspension of registration for dimension requirement offence	31
47 Procedures for suspension and cancellation of registration	32
48 Cancellation or suspension of registration by court under Heavy Vehicle National Law (NSW) or corresponding law	33
Part 4 Authorised and permitted uses of unregistered registrable vehicles	
Division 1 Unregistered vehicle permits	
49 Issue of unregistered vehicle permits	34
Division 2 Trader's plates	
50 Issue of trader's plates	34
51 Use of vehicles with trader's plates on road or road related area	35
52 Purposes for which trader's plates may be used	35
53 Trader to keep and produce record	36

	Page
54 Questions regarding use of plate to be answered	36
55 Disposal or cessation of business	36
56 Return of trader's plate	37
Division 3 Persons unaware of registration status	
57 Vehicles being driven in the course of motor industry business	37
58 Vehicles being driven by persons unaware of registration status	37
Part 5 Vehicle standards	
Division 1 General requirements	
59 Applicable vehicle standards	38
60 Registrable vehicles to comply with applicable vehicle standards	38
Division 2 Standards and certifications	
61 Compliance with vehicle standards	39
62 Non-complying and non-standard vehicles	40
63 Operations plates and certificates of approved operations	40
64 Modifications to registered light vehicles	40
65 Construction of or modification to registered vehicles	41
Division 3 Inspections	
Subdivision 1 When vehicles may be inspected	
66 Directed inspections	41
67 Periodic inspections	41
Subdivision 2 Authorised examiners and inspection stations	
68 Examiner's authorities	42
69 Proprietor's authorities	43
70 Authority may issue rules for the purposes of this Subdivision	44
71 Books of inspection reports	45
72 Suspension or cancellation of examiner's authorities and proprietor's authorities	45
73 Committee of review	45
74 Notification of decisions by Authority	46
Division 4 Component identification numbers	
75 Definitions	47
76 Allotment of component identification numbers	47
77 Altering component identification numbers of vehicle parts without authority	47
78 Change or replacement of vehicle part	47
79 Interference with component identification number	48
Division 5 Vehicle defect notices issued under the Act	
80 Issue of vehicle defect notices and formal warnings	48
81 Recording, clearance and withdrawal of vehicle defect notices	49

	Page
Part 6	Certification of vehicles
Division 1	Preliminary
82	Definitions 51
Division 2	Significantly modified vehicles
83	Significant modifications to vehicles 51
84	Modified vehicles not to be used unless certified 51
Division 3	Compliance certificates
85	Compliance certificate may be issued 51
86	Authority may cancel compliance certificate 52
87	Person may drive vehicle for purpose of compliance certificate 52
Division 4	Licensing of certifiers
88	Definition 53
89	Applications with respect to licences 53
90	Licences 53
91	Consultation before making certain decisions 54
92	Immediate suspensions 54
93	Record keeping requirements 54
94	Insurance 55
95	Offence of holding out 55
96	Service of notices under Part 56
Part 7	Written-off vehicles
Division 1	Preliminary
97	Definitions 57
98	Meaning of “written-off vehicle” 58
Division 2	Non-repairable damage
99	Non-repairable damage—vehicles other than motor bikes or trailers 58
100	Non-repairable damage—motor bikes 59
101	Non-repairable damage—trailers 59
Division 3	Authorisations to repair
102	Vehicles that are not eligible for the issue of authorisation to repair 60
103	Eligibility to apply for an authorisation to repair 60
104	Term of authorisations to repair 60
Division 4	Assessment of vehicles
105	Prescribed qualifications to carry out vehicle damage assessments 60
106	Standards of repairs and repair methods 61
107	Records about vehicle damage assessments 61
Division 5	Notifications about written-off vehicles
108	Notification of information about vehicles assessed as a total loss 62
109	Notification of information about vehicles not assessed as a total loss 62

	Page
110 Prescribed information about vehicles disposed of to motor vehicle recycler	62
111 Prescribed information about demolished or dismantled vehicles	63
Division 6 Records about other vehicles	
112 Records required to be kept by insurers of information about certain vehicles assessed as not being total losses	63
Division 7 Written-off vehicle warning labels	
113 Obligation to attach written-off vehicle warning labels	63
114 Content and form of written-off vehicle warning label	64
115 Positioning of written-off vehicle warning label	64
116 Offence to alter, damage, destroy, remove or interfere with written-off vehicle warning label	64
Division 8 Certificates of compliance	
117 Standards of repairs and repair methods	64
118 Certificates of compliance in relation to electronic control systems	64
119 Issue of certificates of compliance	64
120 Term of certificates of compliance	64
121 Records of certificates of compliance	65
Division 9 Special provisions for certain vehicles	
122 Vehicles returned to registered operator by insurer	65
123 Hail-damaged vehicles	65
Part 8 Miscellaneous	
Division 1 Fees, fee refunds and fee exemptions	
124 Fees	67
125 Refunds of fees	67
126 Refunds of number-plate fees	68
127 Exemption for eligible pensioners	68
Division 2 Offences	
128 Use of vehicle offences	68
129 Number-plate and registration certificate and label offences	69
130 Notification offences	69
Division 3 Disposal of forfeited vehicles	
131 How forfeited vehicles may be disposed of under section 79 of the Act	70
132 Proceeds of sales of vehicles seized under section 79 of the Act	70
Division 4 Release of information by Authority	
133 Release of information in Register to toll operators	70
134 Release of information of a personal nature	71
135 Release of information to Austroads	71
136 Release of information in Register to CTP insurers	71
137 Release of information for searches	72

	Page	
138	Release of information in Register to Centrelink to verify concession entitlements	73
139	Release of information in Register to SIRA	73
140	Release of information to National Heavy Vehicle Regulator	74
Division 5 Other provisions		
141	Application of Part 3A and clause 148 of Road Transport (General) Regulation 2013	74
142	Special provisions relating to boat trailers	74
143	Photographic evidence of unauthorised vehicle use: section 135 of Act	74
144	Savings	75
Schedule 1	Application of Chapter 4 of Act and Regulation	76
Schedule 2	Light Vehicle Standards Rules	82
Schedule 3	Fees	143
Schedule 4	Registration charges for chargeable heavy vehicles	147
Schedule 5	Amendment of statutory rules under Road Transport Act 2013 No 18	157
Dictionary		163

Road Transport (Vehicle Registration) Regulation 2017

under the

Road Transport Act 2013

Part 1 Preliminary

1 Name of Regulation (cf 2007 reg cl 1)

This Regulation is the *Road Transport (Vehicle Registration) Regulation 2017*.

2 Commencement (cf 2007 reg cl 2)

This Regulation commences on 1 September 2017.

Note. This Regulation replaces the *Road Transport (Vehicle Registration) Regulation 2007*, which is repealed on 1 September 2017 by section 10 (2) of the *Subordinate Legislation Act 1989*.

3 Definitions (cf 2007 reg cl 3)

(1) Expressions used in this Regulation (or in any particular provision of this Regulation) that are defined in the Dictionary at the end of the Regulation have the meanings set out in the Dictionary.

(2) Notes included in this Regulation do not form part of this Regulation.

Note. For the purposes of comparison, provisions of this Regulation contain bracketed notes in headings drawing attention ("cf") to equivalent or comparable (though not necessarily identical) provisions of:

- (a) the *Road Transport (Vehicle Registration) Regulation 2007 (2007 reg)* as in force immediately before the repeal of that Regulation by section 10 (2) of the *Subordinate Legislation Act 1989*, and
- (b) the *Australian Light Vehicle Standards Rules 2015 (ALVSR 2015)*, being national uniform legislation that is reproduced, with some modifications, in Schedule 2 to this Regulation.

4 Applications through agents (cf 2007 reg cl 7)

(1) An application under this Regulation that may be made to the Authority by a person (the **applicant**) may be made:

- (a) by the applicant personally, or
- (b) on behalf of the applicant by an agent.

(2) The Authority may refuse to grant an application that appears to the Authority to be made on behalf of an applicant by an agent if the agent does not provide the Authority with:

- (a) evidence of the agent's identity in a form acceptable to the Authority, and
- (b) a document evidencing the authority of the agent to act as agent for the applicant.

Part 2 Registration process

Division 1 Eligibility for registration

5 Persons eligible to be registered operators of registrable vehicles (cf 2007 reg cl 5)

- (1) A person is eligible to be the registered operator of a registrable vehicle if the person is:
 - (a) an individual who has attained the requisite age, or
 - (b) a corporation.
- (2) Despite subclause (1), the Authority may record in the Register that an individual is the registered operator of a registrable vehicle even though the individual has not attained the requisite age if the Authority is satisfied that it is appropriate to do so. Any such individual is, for the purposes of this Regulation (including renewal of registration), taken to have been eligible to be the registered operator of the vehicle.
- (3) In this clause, *requisite age* means 16 years of age.

6 Registrable vehicles eligible to be registered (cf 2007 reg cl 6)

- (1) A registrable vehicle is eligible to be registered without conditions if:
 - (a) the vehicle complies with the applicable vehicle standards for the vehicle, and
 - (b) the requirements of any applicable third party insurance legislation and duty legislation are complied with in respect of the vehicle, and
 - (c) the vehicle is owned by, or is under the management of, a person who is eligible to be the registered operator of the vehicle.
- (2) However, the Authority may refuse to register a registrable vehicle if the Authority is satisfied that:
 - (a) the vehicle has been registered in another State or Territory, and
 - (b) the registration in that State or Territory has been cancelled or suspended, and
 - (c) the reasons for the cancellation or suspension still exist.

Division 2 Applications for registration

7 Persons eligible to be registered operators may apply for registration (cf 2007 reg cl 7 (1))

A person who is eligible to be the registered operator of a registrable vehicle may apply to the Authority for registration of the vehicle.

8 Form of application (cf 2007 reg cl 8)

- (1) An application for registration of a registrable vehicle must be in a form approved by the Authority.
- (2) The Authority may require the applicant for registration of a registrable vehicle to provide the Authority information about:
 - (a) the identity and home address of the applicant, and
 - (b) an address for the service of notices, and
 - (c) the proposed garage address of the vehicle, and
 - (d) fees, premiums, imposts and similar amounts relating to the vehicle under third party insurance legislation and duty legislation that have been paid or that are payable, and

- (e) any other matter relevant to the decision whether to register the vehicle or to record the applicant in the Register as the registered operator of the vehicle.

Note. Section 4 of the Act defines *home address*, in relation to a body corporate that has a registered office in Australia, to mean the address of its registered office.

9 Supporting evidence (cf 2007 reg cl 9)

- (1) The Authority may request an applicant for registration of a registrable vehicle to submit evidence, in a form approved by the Authority, verifying:
 - (a) the identity of the applicant, and
 - (b) the means by which the vehicle came into the ownership, or under the management, of the applicant, and
 - (c) the proposed garage address of the vehicle, and
 - (d) that the vehicle complies with the applicable vehicle standards for the vehicle, and
 - (e) the acceptability of non-standard or non-complying vehicles, and
 - (f) any other information specified by the Authority in the application form.
- (2) In addition to the evidence that may be required under subclause (1), the Authority may request an applicant for registration of a registrable vehicle that has a vehicle identifier that is the same as the vehicle identifier of a vehicle recorded on the NSW written-off vehicles register to submit any of the following:
 - (a) a valid receipt for any repairs made to the vehicle,
 - (b) if the vehicle was repaired using a part of another vehicle—a valid receipt for the purchase of that part, being a receipt that contains the vehicle identifier of the other vehicle,
 - (c) any other information specified by the Authority.
- (3) In this clause:
valid receipt means a receipt:
 - (a) that is an original document, and
 - (b) that contains the name and Australian Business Number of the relevant repairer or trader, and
 - (c) that is dated, and
 - (d) that contains any other information required by the Authority.

10 Lodgment of application, supporting evidence and payment (cf 2007 reg cl 10)

- (1) An applicant for registration of a registrable vehicle must submit to the Authority:
 - (a) the application for registration, and
 - (b) any supporting evidence required by the Authority, and
 - (c) payment, or evidence of payment, of the following:
 - (i) any applicable fee for registration of the vehicle,
 - (ii) any applicable fee for the issue of number-plates,
 - (iii) any applicable fee for the inspection of the vehicle,
 - (iv) any relevant registration charge for the vehicle,
 - (v) any applicable fees, premiums, imposts and similar amounts relating to the vehicle under third party insurance legislation and duty legislation.
- (2) An eligible pensioner is not required to pay any applicable fee for registration of a vehicle.

- (3) An applicant is not required to pay any applicable fee or relevant registration charge in relation to a vehicle if the Authority is of the opinion that:
 - (a) the applicant was the registered operator of a registrable vehicle that was destroyed or rendered beyond repair as a consequence of damage caused to the vehicle by an occurrence that gave rise to an emergency, and
 - (b) the vehicle to which the application relates is a replacement for the damaged vehicle, and
 - (c) in the circumstances of the case it would be inappropriate to require payment of the fee or charge.
- (4) In this clause:
emergency has the same meaning as in the *State Emergency and Rescue Management Act 1989*.

11 Duration of registration (cf 2007 reg cl 11)

- (1) An applicant for registration of a registrable vehicle must nominate the period for which the applicant is seeking to register the registrable vehicle.
- (2) If the application relates to a registrable vehicle that is not a seasonal vehicle, that period must be one of the following:
 - (a) 3 months,
 - (b) 6 months,
 - (c) 1 year.
- (3) Despite subclauses (1) and (2), an applicant may nominate, and the Authority may approve, a different period of registration for any light vehicle if the Authority:
 - (a) considers that it is necessary to do so to achieve a common registration expiry date for vehicles in a fleet, or
 - (b) otherwise considers it appropriate, in the circumstances, to do so.

12 Determination of applications (cf 2007 reg cl 12)

- (1) The Authority may refuse an application for registration of a registrable vehicle if:
 - (a) the vehicle is not eligible to be registered under clause 6, or
 - (b) a provision of this Regulation prevents approval of the application, or
 - (c) the applicant has not complied with a provision of the Act or this Regulation in relation to the registration of the vehicle (including any requirement to submit or pay any fee), or
 - (d) the Authority reasonably believes that:
 - (i) the vehicle or a part of the vehicle is or may be stolen, or
 - (ii) information given in the application for registration is false or misleading, or
 - (iii) there are unpaid fines or pecuniary penalties arising out of the use of the vehicle in Australia, or
 - (iv) the vehicle is being used for an unlawful purpose, or
 - (e) the applicant fails to comply with the requirements of or under a law in force in this State relating to inspection of registrable vehicles, or
 - (f) a court has made an order under section 598 (3) of the *Heavy Vehicle National Law (NSW)* (or under a provision of the law of another State or Territory that substantially corresponds to that provision) in relation to the heavy vehicle for a stated period and the period has not expired, or

- (g) the Authority is, for any reason whatsoever, of the opinion that the applicant is not a fit and proper person to be the registered operator of the vehicle.

Note. A vehicle cannot be registered unless the Authority is satisfied that the vehicle's garage address is in New South Wales: see section 65 of the Act.

- (2) If the Authority approves an application for registration of a registrable vehicle, the Authority must record the applicant in the Register as the registered operator of the vehicle.

13 Conditional registration (cf 2007 reg cl 13)

- (1) The Authority may register a registrable vehicle conditionally if:
 - (a) the vehicle does not comply with an applicable vehicle standard for the vehicle, or
 - (b) the Authority considers it appropriate for some other reason to register the vehicle conditionally.
- (2) The Authority may refuse to register a registrable vehicle conditionally under subclause (1) (a) if:
 - (a) the vehicle does not bear an operations plate or identification plate relating to the vehicle, or
 - (b) a certificate of approved operations has not been issued or accepted by the Authority in respect of the vehicle.
- (3) In determining the conditions to be imposed on the registration of a registrable vehicle that does not comply with an applicable vehicle standard for the vehicle, the Authority must take into account the nature and extent of any failure of the vehicle to comply with the applicable vehicle standards for the vehicle and any resulting safety risk.
- (4) The Authority may, at any time, vary any conditions that it imposes on the registration of a registrable vehicle.
- (5) The Authority must notify the registered operator in writing of any conditions, or any variation of the conditions, applicable to the registration of a registrable vehicle. The conditions have effect, or the variation of conditions has effect, only on the notification of the registered operator.

Division 3 The Register

14 Maintenance of the Register (cf 2007 reg cl 14)

(1) General matters to be recorded in respect of vehicle

If the Authority registers a registrable vehicle, the Authority must record in the Register, in respect of the vehicle:

- (a) the name, home address and address for the service of notices (if any) of the registered operator, and
- (b) the identification details of the vehicle, and
- (c) the vehicle's garage address, and
- (d) the expiry date of the registration, and
- (e) if the vehicle is conditionally registered—the conditions of registration, and
- (f) the vehicle's GVM (if applicable to the vehicle concerned), and
- (g) the vehicle's GCM (if applicable to the vehicle concerned), and
- (h) in the case of a heavy vehicle—the vehicle's nominated configuration, and

- (i) the name of any insurer providing third party insurance in respect of the vehicle.

Note. Section 4 of the Act defines *home address*, in relation to a body corporate that has a registered office in Australia, to mean the address of its registered office.

(2) **Other matters that may be recorded**

The Authority may record in the Register other information for:

- (a) the purposes of the Act and this Regulation, or
- (b) the purposes of another Act, or
- (c) any other purposes that the Authority considers to be appropriate.

(3) **Recording of failures to comply with production notices**

The Authority must record details of any finding of guilt under section 243 of the Act in the Register or another register kept by the Authority.

(4) **Changes in description or configuration to be recorded**

The Authority must record in the Register any change in the registrable vehicle's description or nominated configuration that is recorded in the Register of which the Authority has been notified under the Act or this Regulation unless the Authority is satisfied that the description or nominated configuration is false.

(5) **Evidence may be required to verify changes in description or configuration**

The Authority may require evidence in a form acceptable to the Authority verifying that the changes referred to in subclause (4) are correct.

(6) **Register to record information over previous 24 months**

The Authority must ensure that the Register contains details of all registrable vehicles that are currently registered or that have been registered within the previous 24 months.

(7) **Requests for Register searches**

The registered operator of a registrable vehicle is entitled to request a search of the Register or other register kept under subclause (3), and to obtain a certificate as to any matter appearing in the Register or other register kept under subclause (3), in respect of the vehicle, on payment of any applicable fee for the search.

Note. Personal information contained in the Register or other register kept under subclause (3) is subject to the *Privacy and Personal Information Protection Act 1998*.

(8) **Recording of dealing restrictions**

The Authority may also record in the Register information for the purpose of identifying a dealing restriction with respect to a registrable vehicle.

(9) **Effect of recorded dealing restrictions**

If a dealing with respect to a registrable vehicle contravenes a dealing restriction recorded in the Register in respect of the vehicle, the Authority may:

- (a) if the dealing requires the approval of the Authority—refuse to approve the dealing, and
- (b) refuse to record details of the dealing in the Register, and
- (c) refuse to exercise any other function of the Authority in connection with that dealing.

(10) **Definitions**

In this clause:

dealing, in relation to a registrable vehicle, means:

- (a) the registration of the vehicle, or
- (b) the renewal of the registration of the vehicle, or
- (c) the transfer of the registration of the vehicle.

dealing restriction, in relation to a registrable vehicle, means any restriction on a dealing with respect to the vehicle that the Authority has determined should apply to the vehicle.

Division 4 Registration documents

15 Certificates of registration (cf 2007 reg cl 15)

The Authority must, on registering a registrable vehicle, issue the registered operator of the vehicle a certificate of registration that includes the following:

- (a) the name of the registered operator,
- (b) the address (if any) for the service of notices on the registered operator,
- (c) the garage address of the vehicle,
- (d) the registration number of the vehicle,
- (e) the make of the vehicle,
- (f) the vehicle's VIN or, if there is no VIN, any chassis number and engine number of the vehicle,
- (g) the vehicle's GVM (if applicable to the vehicle concerned),
- (h) the vehicle's GCM (if applicable to the vehicle concerned),
- (i) in the case of a heavy vehicle—the applicable charging category for the vehicle for the purposes of Schedule 2 to the Act,
- (j) in the case of a light vehicle—the applicable motor vehicle tax for the vehicle under the *Motor Vehicles Taxation Act 1988*,
- (k) the expiry date of the registration,
- (l) if the vehicle is conditionally registered—the conditions to which registration of the vehicle is subject,
- (m) any other information that the Authority considers appropriate.

16 Registration labels for certain registrable vehicles (cf 2007 reg cl 16)

- (1) The Authority must, on registering a heavy vehicle, or on conditionally registering any registrable vehicle, issue the registered operator of the vehicle a registration label that includes the following:
 - (a) the registration number of the vehicle,
 - (b) its make,
 - (c) its model or body type (whichever is the more descriptive),
 - (d) its VIN or, if there is no VIN, any chassis number and engine number,
 - (e) the expiry date of the vehicle's registration,
 - (f) if the vehicle is conditionally registered—a code indicating that the vehicle is conditionally registered,
 - (g) the vehicle's GVM (if applicable to the vehicle concerned),
 - (h) the vehicle's GCM (if applicable to the vehicle concerned),
 - (i) if the vehicle is a heavy vehicle—the applicable charging category for the vehicle for the purposes of Schedule 2 to the Act in coded form.

- (2) A registration label must be affixed:
 - (a) in the case of a motor vehicle fitted with a windscreen or fixed windows:
 - (i) to the lower left (or near side) portion of the front windscreen, or
 - (ii) to any fixed window on the left (or near) side of the vehicle, and
 - (b) in the case of a caravan or other trailer:
 - (i) on or adjacent to the vehicle's number-plate in such a manner that the characters on the number-plate are not obscured, or
 - (ii) if the vehicle has a fixed rear window or a hinged rear window that is to be closed when the caravan or other trailer is being towed—to that window, in a location as close as possible to the vehicle's number-plate, and
 - (c) in any other case—on or adjacent to the vehicle's rear number-plate in such a manner that the characters on the number-plate are not obscured.
- (3) The registration label must be affixed so that the information on the label is readable from the outside of the vehicle.
- (4) Despite subclause (1), the Authority is not required to issue a registration label in respect of a registrable vehicle that is operated by a State or Territory or the Commonwealth or by an authority of a State or Territory or the Commonwealth.

17 Replacement of registration documents (cf 2007 reg cl 16A)

- (1) The Authority may, on payment of any applicable fee, issue a registration document in respect of a registered vehicle to replace a registration document already issued in respect of the vehicle (an *old registration document*) if the Authority is satisfied that:
 - (a) the details of the vehicle's registration recorded in the Register are different from the details on the old registration document, or
 - (b) the old registration document is damaged, or
 - (c) the old registration document is lost, stolen or destroyed.
- (2) On the issue of a registration document to replace an old registration document, the registered operator of the vehicle must (unless the old registration document is lost, stolen or destroyed):
 - (a) destroy the old registration document, or
 - (b) if required to do so by notice in writing from the Authority, return the old registration document to the Authority (or an agent nominated by the Authority) before the date specified in the notice for that purpose.Maximum penalty: 20 penalty units.
- (3) In this clause, *registration document* means a certificate of registration or a registration label.

Division 5 Number-plates

Subdivision 1 Interpretation

18 Definition (cf 2007 reg cl 17)

In this Division:

plate holder, in relation to a number-plate, means:

- (a) in the case of a trader's plate—the trader to whom the trader's plate is issued, or

- (b) in the case of a special number-plate—the person to whom the special number-plate is issued pursuant to the special number-plate arrangements referred to in clause 21, or
- (c) in the case of any other number-plate—the registered operator of the registrable vehicle in respect of which the number-plate is issued.

19 Application of Division to trader's plates (cf 2007 reg cl 18)

This Division (except Subdivisions 3 and 5) does not apply to trader's plates.

Note. Division 2 of Part 4 provides for the issue and use of trader's plates.

Subdivision 2 Issue of number-plates

20 Number-plates generally (cf 2007 reg cl 19)

- (1) If the Authority registers a registrable vehicle, the Authority must assign a distinguishing registration number to the vehicle.
- (2) The Authority must, on payment of any applicable fee for the issue of a vehicle number-plate or number-plates, issue:
 - (a) for each motor vehicle registered by the Authority (other than a motor vehicle referred to in paragraph (b) or (c))—2 vehicle number-plates bearing the registration number assigned to that motor vehicle, and
 - (b) for each motor bike or trailer registered by the Authority—at least 1 vehicle number-plate bearing the registration number assigned to that motor bike or trailer, and
 - (c) for each other registrable vehicle registered by the Authority—the number of vehicle number-plates that the Authority considers appropriate.
- (3) A vehicle number-plate is to conform to any specifications that the Authority determines and must display the matter “NSW” or the words “New South Wales”, or any other words or matter that may be determined:
 - (a) by the Authority with the consent of the Minister in the case of standard number-plates, or
 - (b) by the Authority in the case of special number-plates.

21 Special number-plates (cf 2007 reg cl 20)

- (1) The Authority may issue special number-plates to a person pursuant to arrangements determined by the Authority (referred to in this Division as the *special number-plate arrangements*).
- (2) Special number-plates may be issued to a person for a motor vehicle registered by the Authority (to display the distinguishing registration number assigned to the vehicle) or independently of vehicle registration. Special number-plates issued independently of vehicle registration must be kept in the possession of the Authority, unless the Authority otherwise determines in a particular case or class of cases.
- (3) The Authority may set the fees, charges and consideration to be paid for or in connection with the issue of special number-plates and other services provided by the Authority in connection with the issue of special number-plates. However, any such fee, charge or consideration cannot be set in relation to a matter for which a fee is prescribed by Schedule 3.
- (4) The special number-plate arrangements can include provision for the following:
 - (a) the terms and conditions under which special number-plates are issued and the rights and obligations of plate holders in respect of special number-plates,

- (b) the arrangements under which special number-plates issued independently of vehicle registration are to be held in the possession of the Authority (including requirements for the payment of additional fees and charges in connection with that service),
 - (c) providing for the consideration to be paid for or in connection with the issue of a special number-plate to be determined by auction, tender or other competitive process,
 - (d) the issue of replica or souvenir versions of special number-plates,
 - (e) requiring an agreement to be entered into for the issue of special number-plates (being an agreement between the Authority and a person for or in connection with the issue to the person of special number-plates).
- (5) The required agreement for the issue of special number-plates can include provision for the following:
- (a) the terms and conditions under which the special number-plates are issued and the rights and obligations of the plate holder in respect of special number-plates,
 - (b) requiring payment of the fees, charges and consideration that are payable under the special number-plate arrangements for or in connection with the issue of special number-plates,
 - (c) any other matters in connection with special number-plates that the Authority considers appropriate.
- (6) The requirements of the special number-plate arrangements are in addition to the other requirements of this Division relating to the issue of number-plates.
- (7) In this clause, *issue* a number-plate includes allocate, set aside, reserve, transfer and replace a number-plate.

22 Auxiliary number-plates (cf 2007 reg cl 21 and 21A)

- (1) The Authority may, on payment of any applicable fee, issue an *auxiliary number-plate* (in addition to any vehicle number-plates) bearing the registration number assigned to the motor vehicle for which it is issued.
- Note.** Clause 20 requires the Authority to assign a distinguishing registration number to any motor vehicle that is registered (conditionally or otherwise) by the Authority. See clause 13 for conditional registration.
- (2) An auxiliary number-plate cannot be issued for a motor bike or motor trike.
- (3) An auxiliary number-plate is to conform to any specifications that the Authority determines and must display the matter “NSW” or the words “New South Wales”, and any other words or matter that may be determined:
- (a) by the Authority with the consent of the Minister in the case of an auxiliary number-plate that is a standard number-plate, or
 - (b) by the Authority in the case of an auxiliary number-plate that is a special number-plate.
- (4) An auxiliary number-plate must not be displayed unless the rear number-plate of the motor vehicle for which it is issued is obscured by:
- (a) an apparatus attached to the motor vehicle for use in transporting a bicycle, personal mobility device or motor bike, or
 - (b) a trailer or caravan being towed by the motor vehicle, but only if the number-plate of the trailer or caravan is obstructed by an apparatus attached to the trailer or caravan for use in transporting a bicycle or personal mobility device, or

- (c) an implement, a vehicle exempt from registration, or an unregistered registrable vehicle, being towed by the motor vehicle, or
- (d) a trailer being towed by the motor vehicle for the conveyance of a boat, but only if the number-plate of the trailer is obscured by the boat.

23 Authority may alter distinguishing number of registration (cf 2007 reg cl 22)

- (1) The Authority may at any time alter the distinguishing number of the registration of a registrable vehicle or of a number-plate allocated, reserved or set aside by the Authority.
- (2) Without limiting subclause (1), the Authority may alter the distinguishing number of a registrable vehicle if the Authority considers that:
 - (a) there is an error of any kind in the vehicle number-plate issued for the vehicle, or
 - (b) there has been an error of any kind in the issuing of a vehicle number-plate for the vehicle.
- (3) On or before altering the distinguishing number of the registration of a registrable vehicle under this clause, the Authority must give notice in writing to the registered operator of the vehicle requiring the registered operator to return to the Authority, within the period specified in the notice, any number-plate issued in respect of the vehicle.
- (4) The registered operator must comply with the notice.
Maximum penalty: 20 penalty units.
- (5) On receipt of a number-plate returned in accordance with the requirements of a notice given under this clause, the Authority is to issue to the registered operator of the registrable vehicle concerned a replacement number-plate bearing the distinguishing number, as altered, of the registration of the vehicle for each number-plate that is returned.

24 Authority may alter number-plate design (cf 2007 reg cl 22A)

- (1) The Authority may at any time alter the design of a number-plate issued by the Authority. The *design* of a number-plate includes the colour, layout, style and other characteristics of the appearance of a number-plate.
- (2) The Authority may give notice in writing to the registered operator of a vehicle requiring the registered operator to return to the Authority, within the period specified in the notice, any number-plate issued in respect of the vehicle that the Authority has decided to alter the design of.
- (3) The registered operator must comply with the notice.
Maximum penalty: 20 penalty units.
- (4) The Authority alters the design of a number-plate by issuing a replacement number-plate with the altered design.
- (5) In this clause, *issue* a number-plate includes allocate, set aside and reserve a number-plate.

Subdivision 3 Use of number-plates

25 Display of number-plates (cf 2007 reg Sch 2 cl 61)

- (1) The vehicle number-plate issued by the Authority for a vehicle must be permanently affixed to the vehicle so that (assuming the vehicle to be on level ground):

- (a) the number-plate is at all times:
 - (i) in an upright position that is substantially parallel to the vehicle's axles, and
 - (ii) not more than 1.3 metres above ground level, and
- (b) the number-plate is not obscured, defaced or otherwise illegible, and
- (c) the numbers on the number-plate are clearly visible from any point that is:
 - (i) up to 20 metres from the number-plate, and
 - (ii) within an arc of 45 degrees from the surface of the number-plate above or to either side of the vehicle, as shown in figures 1 and 2 of Diagram 1 (in relation to heavy vehicles) and figures 1 and 2 of Diagram 2 (in relation to light vehicles), and
- (d) any cover on the number-plate:
 - (i) is clear, clean, untinted and flat over its entire surface, and
 - (ii) has no reflective or other characteristics that would prevent the successful operation of a device approved for use under a law relating to the detection of traffic offences, and
- (e) in the case of a motor vehicle other than a motor bike—1 number-plate is affixed to the front of the vehicle and another to its rear, and
- (f) in the case of a motor bike or trailer—at least 1 number-plate is affixed to its rear, and
- (g) in the case of a motor vehicle for which number-plates of different sizes are issued—the larger of the number-plates is affixed to the rear of the vehicle.

Diagram 1—Heavy vehicles

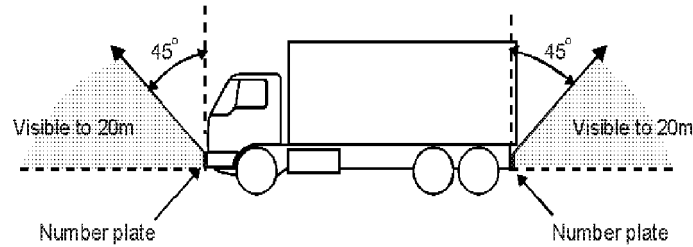

Figure 1

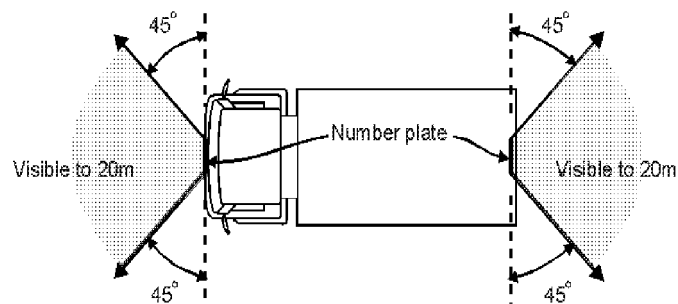

Figure 2

Diagram 2—Light vehicles

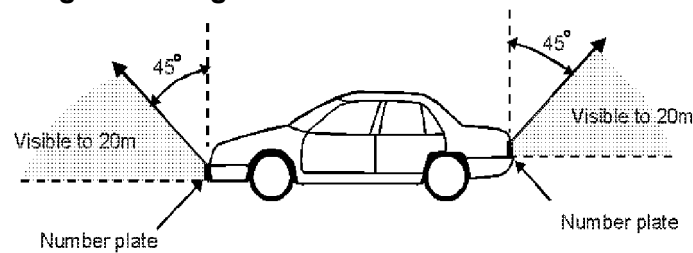

Figure 1

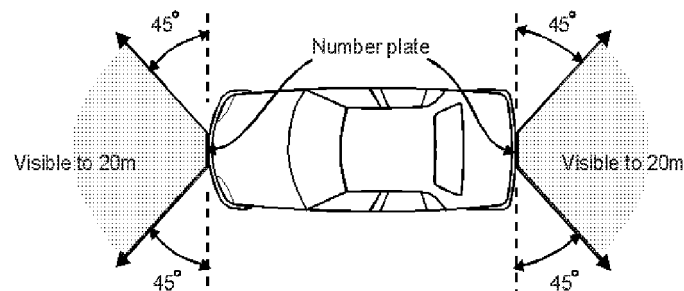

Figure 2

- (2) Subclause (1) (a) does not apply to a vehicle number-plate of a registrable vehicle if:
- (a) due to the construction of the vehicle it is not practicable to comply with that paragraph, and
 - (b) the number-plate is affixed in a manner that complies so far as practicable with that paragraph.

- (3) Subclause (1) (b) does not apply to the rear vehicle number-plate of a registrable vehicle if:
 - (a) the rear number-plate of the registrable vehicle is obscured by a vehicle that is being towed by the registrable vehicle, and
 - (b) the towed vehicle displays a rear number-plate in accordance with subclause (1) or, when the towed vehicle is not required to display a rear number-plate, the registration number of the registrable vehicle is displayed at the rear of the towed vehicle in a manner that complies so far as is practicable with subclause (1).
- (4) Subclause (1) (b) and (c) do not apply to the rear vehicle number-plate of a motor vehicle if an auxiliary number-plate issued for the motor vehicle is displayed, in accordance with clause 22 (4), at the rear of the vehicle in a manner that complies (as far as is practicable) with subclause (1) (a)–(d).
- (5) This clause does not apply to a tow truck that is towing a motor vehicle and displaying a number-plate issued under the *Tow Truck Industry Act 1998* in accordance with the requirements imposed under that Act.

Note. If the number-plate of a tow truck is likely to be obscured by a motor vehicle that is to be towed by the tow truck, clause 47 of the *Tow Truck Industry Regulation 2008* requires that the driver of the tow truck display the number-plate at the rear of the towed vehicle or in such other manner that the number-plate remains clearly visible.
- (6) The Authority may exempt any particular vehicle or class of vehicle from the requirements of this clause.
- (7) An exemption may be granted subject to conditions.
- (8) The Authority may amend or revoke an exemption or a condition made or imposed in accordance with subclause (6) or (7).

Subdivision 4 Reservation, transfer and replacement of number-plates

26 Reservation of number-plates (cf 2007 reg cl 23)

The Authority may, on payment of any applicable fee, reserve a number-plate (or the distinguishing number for a number-plate).

27 Transfer of number-plates (cf 2007 reg cl 24)

- (1) The Authority may, on payment of any applicable fee, transfer number-plates from one vehicle to another.
- (2) The Authority may, on payment of any applicable fee, transfer the reservation of a number-plate (or the distinguishing number for a number-plate).

28 Replacement of surrendered number-plates (cf 2007 reg cl 25)

- (1) The Authority may, on payment of any applicable fee, issue a number-plate to replace an existing number-plate.
- (2) The content and style of a replacement number-plate may be the same as or different from the content and style of the existing number-plate.
- (3) If a replacement number-plate is issued for a registrable vehicle before an existing number-plate for the vehicle is surrendered, the registered operator of the vehicle must surrender any existing number-plate to the Authority within 14 days after the replacement number-plate is issued.
Maximum penalty: 20 penalty units.

Subdivision 5 Damaged, destroyed or missing number-plates

29 Damaged number-plates (cf 2007 reg cl 26)

- (1) The plate holder of a number-plate that has become damaged must surrender the damaged number-plate to the Authority as soon as reasonably practicable for replacement under clause 28.
- (2) The plate holder must at the same time surrender any other number-plate with the same distinguishing number, unless the Authority otherwise approves in a particular case.

Maximum penalty: 20 penalty units.

30 Lost, stolen or destroyed number-plates (cf 2007 reg cl 27)

- (1) If any vehicle number-plate is lost, stolen or destroyed, a plate holder must, as soon as is practicable after discovering the loss, theft or destruction:
 - (a) notify the Authority in writing of the loss, theft or destruction, and
 - (b) deliver to the Authority any other number-plate with the same number unless it too is lost, stolen or destroyed.

Maximum penalty: 20 penalty units.

- (2) If an auxiliary number-plate is lost, stolen or destroyed, the plate holder must, as soon as practicable after discovering the loss, theft or destruction, notify the Authority in writing accordingly.
- (3) The Authority may request any such plate holder:
 - (a) to forward evidence, in a form acceptable to the Authority, verifying the loss, theft or destruction of the number-plate and stating the circumstances connected with it, and
 - (b) if a vehicle number-plate is lost, stolen or destroyed—to pay any applicable fee for replacing a lost, stolen or destroyed number-plate.
- (4) The Authority may issue a new number-plate under clause 28 to replace a number-plate that is lost, stolen or destroyed.
- (5) When the Authority issues a new number-plate to replace a number-plate that is lost, stolen or destroyed, the new number plate must:
 - (a) in the case of a vehicle number-plate—have a distinguishing number that is different from that of the number-plate it replaces, or
 - (b) in the case of an auxiliary number-plate—have the same number as the number-plate it replaces,unless the Authority otherwise approves in a particular case.

31 Recovery of lost or stolen number-plates (cf 2007 reg cl 28)

A person who recovers a lost or stolen number-plate must, as soon as practicable after recovering the number-plate:

- (a) notify the Authority of the recovery, and
- (b) deliver to the Authority the recovered number-plate (unless otherwise directed by the Authority).

Maximum penalty: 20 penalty units.

Subdivision 6 General

32 Return of number-plates (cf 2007 reg cl 28A)

- (1) The Authority may, by notice in writing to a person who has possession of a number-plate issued by the Authority, require the person to return the number-plate to the Authority within the period specified in the notice.
- (2) The person must comply with the notice.
Maximum penalty: 20 penalty units.

33 Special number-plate concession arrangements (cf 2007 reg cl 28B)

- (1) The Authority may use operational information, or release operational information to the special number-plate concessionaire, to facilitate the operation of the special number-plate concession concerned or any subsidiary arrangement.
- (2) A person who obtains operational information in the course of exercising functions under a special number-plate concession or a subsidiary arrangement must not make a record of or disclose the information except:
 - (a) in the exercise of the person's functions under or for the purposes of the special number-plate concession, or
 - (b) with other lawful authority.Maximum penalty: 20 penalty units.
- (3) The Authority may delegate any function of the Authority under this Division (except this power of delegation) to a special number-plate concessionaire.
- (4) In this clause:

operational information means any information obtained by the Authority in the exercise of any function of the Authority, including:

- (a) information in any register kept by the Authority, and
- (b) information that is of a personal nature or that has commercial sensitivity.

special number-plate concession means a commercial arrangement entered into by the Authority for the provision of marketing and other services to the Authority in connection with the issue of special number-plates.

special number-plate concessionaire means a person with whom the Authority enters into a special number-plate concession.

subsidiary arrangement means a commercial arrangement entered into by the special number-plate concessionaire in connection with a special number-plate concession.

34 Possession of number-plates (cf 2007 reg cl 28C)

- (1) A person is guilty of an offence if the person is in possession, without lawful excuse, of number-plates issued by or under the law of New South Wales or any other State or Territory.
Maximum penalty: 30 penalty units.
- (2) A person is guilty of an offence if the person is in possession, without lawful excuse, of number-plates that were not issued by or under the law of New South Wales or any other State or Territory but that could be mistaken for, or resemble, number-plates so issued.
Maximum penalty: 30 penalty units.

Division 6 Renewal of registration

35 Notices of renewal of registration (cf 2007 reg cl 29)

- (1) A notice of renewal of registration is a notice addressed to the registered operator of a registrable vehicle stating that, if the vehicle's existing registration is not renewed on or before a specified date, the registration will expire.
- (2) If the Authority fails to send a notice of renewal, that failure does not affect:
 - (a) the expiry of the vehicle's existing registration, or
 - (b) the obligation of the registered operator to renew the registration of the vehicle if the registered operator intends to use the vehicle on a road or road related area after the expiry of the vehicle's existing registration.

36 Renewal of registration (cf 2007 reg cl 30)

- (1) The registered operator of a registrable vehicle may apply for renewal of the registration of the vehicle by submitting to the Authority:
 - (a) an application for renewal of registration in the form approved by the Authority, and
 - (b) the amount of the relevant registration charge for the vehicle, and
 - (c) the applicable fee for renewal of registration for the relevant period, and
 - (d) payment, or evidence of payment, of any applicable third party insurance premium required by third party insurance legislation in respect of the vehicle.
- (2) However, the Authority may renew the registration of a vehicle if the registered operator is an eligible pensioner (who is not liable to pay any relevant registration charge for the vehicle), without the need for any application.
- (3) The registration of a registrable vehicle may be renewed:
 - (a) not more than 3 months after the expiry of registration of the vehicle, or
 - (b) in the case of a seasonal vehicle—not more than 12 months after the expiry of registration of the vehicle.
- (4) The expiry date of a renewed period of registration must be calculated as if the renewal had commenced:
 - (a) on the day after the day recorded in the register as the expiry date of the period of the registration being renewed, or
 - (b) in the case of a seasonal vehicle—on the first day of the nominated period.
- (5) Subclauses (3) and (4) do not have the effect of retrospectively registering a registrable vehicle.
- (6) The Authority may refuse to renew the registration of a registrable vehicle only if the circumstances are such that if an initial application for registration of the vehicle were being made the Authority would refuse the application under clause 12 (1).

Note. The registration of a vehicle cannot be renewed unless the Authority is satisfied that the vehicle's garage address is in New South Wales: see section 65 of the Act.
- (7) The Authority may, by notice in writing, require the registered operator of a registrable vehicle to return the number-plates of the vehicle to the Authority within the period specified in the notice if:
 - (a) the period during which the registration of a registrable vehicle may be renewed expires, and
 - (b) the registration of the vehicle is not renewed.

- (8) The registered operator must comply with the notice.
Maximum penalty (subclause (8)): 20 penalty units.

Part 3 Alteration of registration status

Division 1 General obligations of registered operators

37 Obligations of registered operators (cf 2007 reg cl 31)

- (1) The registered operator of a registered vehicle must notify the Authority, in a form approved by the Authority, not more than 14 days after a change in:
 - (a) the vehicle's garage address, or
 - (b) the registered operator's name, home address or address for service of notices.
Note. Section 4 of the Act defines **home address**, in relation to a body corporate that has a registered office in Australia, to mean the address of its registered office.
- (2) The registered operator of a heavy vehicle that has been:
 - (a) destroyed or declared by the operator to be a write-off, or
 - (b) declared by an insurer to be a write-off,must notify the Authority of those matters not more than 14 days after their occurrence.
- (3) The registered operator of a registrable vehicle must notify the Authority of any change to the vehicle:
 - (a) that affects the accuracy of its description on the certificate of registration for the vehicle in accordance with clause 15 (e)–(h), or
 - (b) that would cause the operator to incur liability for an additional charge under Schedule 2 to the Act or under the *Motor Vehicles Taxation Act 1988*.
- (4) The registered operator must ensure that a vehicle subject to such a change is not used until after:
 - (a) the Authority has been notified in accordance with subclause (3), and
 - (b) any additional fee or charge attributable to the change has been paid.
- (5) However, the registered operator of a registrable vehicle is not required to notify the Authority of any change that affects the accuracy of the vehicle's description on the certificate of registration for the vehicle if the operator has already provided that information under clause 11 of Schedule 2 to the Act.
- (6) The registered operator of a registrable vehicle must present the vehicle for inspection or testing in accordance with reasonable notice in writing served on the operator by the Authority.
- (7) The registered operator of a registrable vehicle must provide any information reasonably required by the Authority to demonstrate that the garage address recorded in the Register is the vehicle's actual garage address.
Maximum penalty: 20 penalty units.

Division 2 Transfer of registration

38 Obligations of disposers: application for transfer of registration and notification to Authority (cf 2007 reg cl 33)

- (1) A person, or the agent of a person, who disposes of a registered registrable vehicle must, immediately after disposing of the vehicle:
 - (a) complete an application for transfer of registration as disposer in the form approved for that purpose by the Authority and sign it, and
 - (b) give the completed form to the acquirer.

- (2) If the person or agent is a motor dealer, the person or agent must also, immediately after disposing of the vehicle, notify the Authority of the following:
 - (a) the full names and addresses of the following persons:
 - (i) if the motor dealer is an agent for another person—the person on whose behalf the vehicle has been disposed of,
 - (ii) the person who has acquired the vehicle,
 - (b) the date of the disposal,
 - (c) the registration number of the vehicle.
- (3) This clause does not apply to the passing of possession of a registrable vehicle:
 - (a) under any hiring (not being a hiring under a hire-purchase agreement) or under any lending (not being a lending under a lease agreement) of a registrable vehicle, or
 - (b) to an agent for the purposes of sale or disposal, or
 - (c) to a bailee for the purpose of alteration, repair, renovation, garaging, storing or any other similar purpose not involving the use of the vehicle for the benefit of the bailee, or
 - (d) in accordance with an order of a court in Australia or with any other legal process.

39 Obligations of acquirers (cf 2007 reg cl 34)

- (1) A person, or the agent of a person, who acquires a registered registrable vehicle must, within 14 days after acquiring the vehicle:
 - (a) apply to the Authority, in the form approved by the Authority, to transfer the registration of the vehicle to the acquirer, and
 - (b) pay the applicable fee for transfer of the registration of the vehicle and any duty payable under applicable duty legislation, and
 - (c) if the vehicle is acquired in accordance with an order of a court in Australia or with any other legal process, provide the Authority with evidence of the court order or process.

Maximum penalty: 20 penalty units.

- (2) If the applicable fee referred to in subclause (1) includes an additional amount payable by reason of the making of the application after a date or period, the Authority may in a particular case exempt an applicant from liability to pay that additional amount if the Authority is satisfied there is sufficient cause for doing so.
- (3) A person, or the agent of a person, who acquires a registered registrable vehicle is not required to pay the applicable fee referred to in subclause (1) if the person is any of the following:
 - (a) a veteran to whom section 22, 23 or 24 of the *Veterans' Entitlements Act 1986* of the Commonwealth applies,
 - (b) a member or former member (within the meaning of the *Military Rehabilitation and Compensation Act 2004* of the Commonwealth) who suffers from an impairment assessed under that Act to constitute at least 50 impairment points, and who is eligible for, in receipt of, or has at any time received compensation or a special rate disability pension under that Act.
- (4) This clause does not apply to the passing of possession of a registrable vehicle:
 - (a) under any hiring (not being a hiring under a hire-purchase agreement) or under any lending (not being a lending under a lease agreement) of a registrable vehicle, or

- (b) to an agent for the purposes of sale or disposal, or
- (c) to a bailee for the purpose of alteration, repair, renovation, garaging, storing or any other similar purpose not involving the use of the vehicle for the benefit of the bailee.

40 Repossession and restoration (cf 2007 reg cl 35)

- (1) The holder of a security interest in a registered registrable vehicle must notify the Authority, and apply for transfer of the vehicle, not more than 14 days after:
 - (a) taking possession of the vehicle from the registered operator of the vehicle, or
 - (b) returning possession of the vehicle to the registered operator of the vehicle.
- (2) The notification and application must be in a form approved by the Authority.
- (3) The application must be accompanied by the applicable fee for transfer of registration of the vehicle.

41 Registration of the transfer of vehicles and functions of the Authority (cf 2007 reg cl 36)

- (1) The Authority may refuse to register the transfer of registration of a registrable vehicle if:
 - (a) the registrable vehicle is the subject of a vehicle defect notice that:
 - (i) prohibits the use of the vehicle or imposes conditions on the use of the vehicle, and
 - (ii) has not been cleared in accordance with this Regulation or the *Heavy Vehicle National Law (NSW)*, or
 - (b) the vehicle is registered on condition that it not be transferred, or
 - (c) the requirements of this Regulation relating to transfer of registration have not been complied with, or
 - (d) the Authority reasonably believes that the ownership, possession, control or description of the registrable vehicle (or of any part of the registrable vehicle) is uncertain, or
 - (e) the person disposing of, or the person acquiring, the registrable vehicle fails to comply with the requirements of a law relating to inspection of registrable vehicles, or
 - (f) the Authority would refuse an application to register the vehicle under this Regulation, or
 - (g) the Authority has sought further information or supporting evidence in relation to the transfer and the information or evidence has not been furnished to the Authority, or
 - (h) the Authority is for any reason of the opinion that the person to whom the registration is proposed to be transferred is not a fit and proper person to be the registered operator of the vehicle, or
 - (i) the Authority is satisfied that the effective management of the vehicle has not changed.
- (2) The Authority may refuse to register the transfer of registration of a registrable vehicle for which any special number-plate has been issued unless:
 - (a) the registration number has been altered in accordance with this Regulation, and
 - (b) any number-plate issued for the vehicle has been surrendered to the Authority.

- (3) The Authority must refuse to register a transfer of registration of a registrable vehicle if an order of a court in Australia prohibits the transfer of registration of the vehicle, and the Authority has been notified of the order.
- (4) The Authority may register the transfer of a registrable vehicle, despite the failure of one of the parties to the transfer to meet a requirement of this Regulation relating to the transfer of registrable vehicles, if the Authority considers it appropriate to do so in the circumstances.
- (5) If the Authority is advised by the registered operator of a registrable vehicle that the vehicle has been disposed of, the Authority may make an entry in the Register to that effect pending the receipt of the application for transfer.
- (6) If the Authority registers a transfer of a registrable vehicle, the Authority must issue a new certificate of registration or issue a form of transfer of registration to the person acquiring the vehicle.
- (7) The Authority may, subject to any condition that it thinks fit, exempt any person or class of persons from all or any provisions of this Division (other than this subclause).

42 Transfer on death of registered operator (cf 2007 reg cl 37)

- (1) On notification of the death of the registered operator of a registrable vehicle, the Authority may transfer the registration to any person who applies to the Authority for the transfer if:
 - (a) the person proves to the satisfaction of the Authority that the person is reasonably entitled to the transfer, and
 - (b) any applicable fee in respect of the transfer is paid.
- (2) A transfer may be cancelled by the Authority if, during the currency of the registration, any person produces probate of the will or letters of administration granted to the person for the estate of the deceased and applies, pursuant to the will or letters of administration, to have the registration transferred to a person other than the person to whom the registrable vehicle has been transferred under subclause (1).
- (3) A person to whom the registration has been transferred under subclause (1) must, in the event of the transfer being cancelled, immediately deliver the certificate of registration to the Authority on being requested to do so.
Maximum penalty (subclause (3)): 20 penalty units.

Division 3 Expiry of registration

43 Expiry of registration (cf 2007 reg cl 39)

- (1) The registration of a registrable vehicle expires at the end of the day recorded in the Register as the vehicle's registration expiry date.
- (2) A renewal of a registration takes effect:
 - (a) from the expiry of the registration, or
 - (b) if reissued by the Authority to take effect from an earlier day—from that day.
- (3) If the registration of a registrable vehicle expires, the Authority may, by notice in writing to the registered operator, require the registered operator to return the vehicle's number-plates to the Authority (or an agent nominated by the Authority) within the period specified in the notice.
- (4) The registered operator must comply with the notice.
Maximum penalty (subclause (4)): 20 penalty units.

Division 4 Surrender, suspension and cancellation of registration

44 Surrender of registration by registered operator (cf 2007 reg cl 40)

- (1) The registered operator of a registrable vehicle may apply to the Authority to surrender the registration of the vehicle.
- (2) The Authority must approve an application for the surrender of the registration of a registrable vehicle unless:
 - (a) the registered operator of the vehicle has failed to meet the requirements of this Regulation, or
 - (b) the Authority is taking action to suspend or cancel the registration.

Note. Division 1 of Part 8 provides for the refund of fees in the case of a surrender or cancellation of registration.

45 Suspension or cancellation of registration by Authority (cf 2007 reg cl 41)

- (1) The Authority may suspend or cancel the registration of a registrable vehicle in accordance with this Division if:
 - (a) a vehicle defect notice relating to the vehicle has not been complied with and the date for compliance specified in the notice has expired, or
 - (b) the vehicle does not comply with the applicable vehicle standards for the vehicle, or
 - (c) any amounts payable in relation to the vehicle under duty legislation, the Act or this Regulation have not been paid, or
 - (d) the vehicle ceases to be an insured motor vehicle within the meaning of the *Motor Accidents Compensation Act 1999*, or

Note. Section 14 of the *Motor Accidents Compensation Act 1999* requires RMS to comply with a request by a licensed insurer to suspend or cancel the registration of a motor vehicle in certain circumstances.

 - (e) a payment in a form other than cash submitted to the Authority as payment of a relevant registration charge or fees or duty is dishonoured, or
 - (f) a penalty imposed on the registered operator of the vehicle in respect of the operation of the vehicle is unpaid and no court order for the payment of a penalty by instalments has been made, or
 - (g) the registered operator of the vehicle has not complied with a court order for the payment by instalments of a penalty imposed on the registered operator in respect of the operation of the vehicle, or
 - (h) the vehicle has been destroyed or damaged beyond repair, or
 - (i) the Authority reasonably believes that the ownership, possession, control or description of the registrable vehicle (or of any part of the registrable vehicle) as recorded in the Register is uncertain, or
 - (j) the Authority has approved an application to surrender registration of the vehicle, or
 - (k) any tax on the vehicle under the provisions of any Act is due and unpaid, or
 - (l) the Authority is satisfied that the registration has been issued erroneously, or
 - (m) the Authority is, for any reason, of the opinion that the registered operator of the vehicle is not a fit and proper person to be the registered operator, or
 - (n) the registered operator of the vehicle has failed to comply with a requirement imposed by or under this Regulation to return or surrender a number-plate for the vehicle.

- (2) The Authority may suspend the registration of a registrable vehicle for a period not exceeding 3 months if the Authority is satisfied, on the balance of probabilities, that the registered operator of the vehicle has failed to use or manage the vehicle so as to effectively prevent repeated violations of the traffic law (whether by the registered operator or by another person authorised to use the vehicle).
- (3) The Authority may suspend the registration of a registrable vehicle if it appears to the Authority that the registered operator of the vehicle (being a corporation) has committed a second or subsequent offence under section 188 (1) of the Act or a former corresponding provision in relation to any vehicle of the registered operator in any 3 year period.
- (4) The Authority may suspend the registration of a heavy vehicle for a period not exceeding 3 months if 3 or more M5 East Tunnel vehicle emission offences involving the vehicle are committed.
- (5) An **M5 East Tunnel vehicle emission offence** is an offence under clause 16 (1) of the *Protection of the Environment Operations (Clean Air) Regulation 2010* in relation to the emission of excessive air impurities by a heavy vehicle being used in the M5 East Tunnel.
- (6) An M5 East Tunnel vehicle emission offence is committed if:
 - (a) a court convicts a person of the offence (whether or not it imposes any penalty), or
 - (b) an amount is paid under a penalty notice in respect of the offence, or
 - (c) a penalty notice enforcement order under the *Fines Act 1996* is made against a person in respect of the offence.
- (7) Clause 47 does not apply to a decision to suspend registration under subclause (2), (3) or (4). However, before suspending the registration of a vehicle under any of those subclauses, the Authority:
 - (a) must give the registered operator of the vehicle notice in writing of the matters referred to in clause 47 (1) (a) and (b) and the period of suspension, and
 - (b) may follow such other procedures prescribed by clause 47 or any other procedures that it considers appropriate.
- (8) In this clause, **traffic law** means:
 - (a) a provision of Chapter 4 of the Act or this Regulation, or
 - (b) any other provision of the road transport legislation.

46 Suspension of registration for dimension requirement offence (cf 2007 reg cl 41A)

- (1) The Authority may suspend the registration of a heavy vehicle for a period not exceeding 3 months if:
 - (a) a dimension requirement offence involving the vehicle has been committed and one of the following applies:
 - (i) a court has convicted a person of the offence (whether or not it has imposed any penalty),
 - (ii) an amount has been paid under a penalty notice for the offence,
 - (iii) a penalty notice enforcement order under the *Fines Act 1996* has been made against a person for the offence, or
 - (b) the Authority is satisfied that a dimension requirement offence involving the vehicle has been committed and the vehicle:
 - (i) caused damage to road infrastructure, or
 - (ii) was involved in an accident, or

- (iii) caused a danger or obstruction to traffic, or
- (iv) caused an adverse effect on public amenity.

Note. A decision of the Authority to suspend the registration of a heavy vehicle under this subclause is an appealable decision in respect of which a person affected has a right of appeal to the Local Court. See sections 266 and 267 of the Act.

- (2) A ***dimension requirement offence*** is:
 - (a) an offence against rule 102, 103, 104 or 106 (2) of the *Road Rules 2014*, or
 - (b) an offence against section 96 or 102 of the *Heavy Vehicle National Law (NSW)*.
- (3) Clause 47 does not apply to a decision to suspend registration under subclause (1). However, before suspending the registration of a heavy vehicle under that subclause, the Authority:
 - (a) must give the registered operator of the vehicle notice in writing of the matters referred to in clause 47 (1) (a) and (b) and the period of suspension, and
 - (b) may follow any other procedures prescribed by clause 47 or any other procedures that it considers appropriate.

47 Procedures for suspension and cancellation of registration (cf 2007 reg cl 42)

- (1) If the Authority decides to suspend the registration of a registrable vehicle, the Authority must give the registered operator notice in writing of:
 - (a) the reasons for the suspension, and
 - (b) the date on which the registration is to be suspended, and
 - (c) the action to be taken by the registered operator in order to avoid the suspension or to have the suspension removed.
- (2) The Authority must not cancel the registration of a registrable vehicle unless the Authority:
 - (a) has suspended the registration and believes that a reason for the suspension still exists, and
 - (b) has served notice on the registered operator that:
 - (i) advises the registered operator that the Authority has decided to cancel the registration of the vehicle and gives the reasons for the decision, and
 - (ii) specifies requirements that must be met if the cancellation is to be avoided, and
 - (iii) states that, if those requirements are not met within 14 days after the date specified in the notice for that purpose, the cancellation will then take effect, and
 - (iv) if there is a right under Part 7.8 of the Act to appeal against the decision—advises the registered operator of the right of appeal.
- (3) Subclause (2) does not apply:
 - (a) in the case of a cancellation following a surrender of registration by the registered operator under this Division, or
 - (b) if the Authority is directed to cancel the registration by the Commissioner of Fines Administration under the *Fines Act 1996*, or
 - (c) if the Authority is required to cancel the registration by virtue of section 84 of the Act.
- (4) If the requirements stated in the notice referred to in subclause (2) are not met within the period specified in the notice, the registration of the vehicle is cancelled at the end of that period.

- (5) If the registration of a vehicle is cancelled, the registered operator must:
- (a) destroy any registration label for the vehicle as soon as practicable after the registration is cancelled, and
 - (b) return any number-plates issued in respect of the registration to the Authority (or an agent nominated by the Authority) within 14 days after the registration is cancelled.
- Maximum penalty: 20 penalty units.
- (6) On cancelling the registration of a registrable vehicle, the Authority may require the registered operator of the vehicle to pay the applicable fee for the cancellation.

48 Cancellation or suspension of registration by court under Heavy Vehicle National Law (NSW) or corresponding law (cf 2007 reg cl 42A)

- (1) The registration of a heavy vehicle under this Regulation is cancelled or suspended in accordance with an order made by a court under section 598 (2) of the *Heavy Vehicle National Law (NSW)* (or under a provision of the law of another State or Territory that substantially corresponds to that provision) in relation to the heavy vehicle.
- (2) The Authority is to take all appropriate steps to give effect to the order.

Part 4 Authorised and permitted uses of unregistered registrable vehicles

Division 1 Unregistered vehicle permits

49 Issue of unregistered vehicle permits (cf 2007 reg cl 43)

- (1) The Authority may issue an unregistered vehicle permit for a registrable vehicle that complies with any applicable third party insurance legislation if:
 - (a) it would be unreasonable or impracticable to require that the vehicle be registered during a particular period, or
 - (b) the vehicle has been driven, under clause 17 of Schedule 1, to a place for the purpose of obtaining registration and registration has been refused.
- (2) An unregistered vehicle permit authorises, subject to any condition specified in the permit, use of a registrable vehicle on:
 - (a) a road or road related area, or
 - (b) particular roads or road related areas.
- (3) Unless sooner revoked, an unregistered vehicle permit expires on the expiry date recorded in the permit:
 - (a) if the permit specifies an expiry time—at that time on the expiry date, or
 - (b) if no expiry time is specified—at the end of the day recorded as the expiry date.
- (4) If the Authority issues an unregistered vehicle permit, the Authority must:
 - (a) record details of the permit, including any condition to which the permit is subject, in the Register, and
 - (b) assign a temporary identification number to the vehicle.
- (5) Except if otherwise approved by the Authority, an applicant for an unregistered vehicle permit must pay to the Authority any applicable fee for issue of the permit before it is issued.
- (6) The holder of the permit must not use the vehicle on a road or road related area unless the holder:
 - (a) displays a notice affixed securely to the vehicle in a prominent position depicting the temporary identification number assigned to the vehicle by the Authority, and
 - (b) displays any information that may be required or authorised by the Authority.
- (7) An unregistered vehicle permit may be revoked or varied at any time by the Authority.

Division 2 Trader's plates

50 Issue of trader's plates (cf 2007 reg cl 44)

- (1) The Authority may, on payment of any applicable fee, issue one or more trader's plates to any person that the Authority is satisfied:
 - (a) is a manufacturer or repairer of, or motor dealer in, unregistered registrable vehicles, or
 - (b) provides some other service in relation to unregistered registrable vehicles that is incidental to the manufacture or repair of, or dealings in, those vehicles, being a service that the Authority is satisfied requires the use of trader's plates.

- (2) The Authority is not to issue a trader's plate to a person unless the Authority is satisfied that the person carries on business from premises that the Authority considers to be suitable for the issue of trader's plates.
- (3) A trader's plate issued under this clause:
 - (a) must conform to any specifications that the Authority may determine, and
 - (b) must display:
 - (i) the matter "NSW" and any other words that the Authority may determine with the approval of the Minister, or
 - (ii) the words "New South Wales" and any other words that the Authority may determine with the approval of the Minister, and
 - (c) remains the property of the Authority.

51 Use of vehicles with trader's plates on road or road related area (cf 2007 reg cl 45)

For the purposes of section 68 (2) (b) of the Act, a registrable vehicle to which a trader's plate is attached may be used on a road or road related area only if the use of the vehicle is an authorised use under this Division.

52 Purposes for which trader's plates may be used (cf 2007 reg cl 46)

- (1) The use of a registrable vehicle to which a trader's plate is affixed on a road or road related area is an authorised use if the vehicle (or in the case of a trailer, the vehicle by which it is drawn):
 - (a) is conveying the trader to whom the plate has been issued or the trader's authorised employee or agent, and is being driven:
 - (i) for a purpose connected with its manufacture or repair or connected with a dealing in the vehicle, or
 - (ii) for a purpose connected with a service provided in relation to unregistered registrable vehicles that is incidental to the manufacture or repair of, or dealings in, those vehicles, being a service that the Authority is satisfied requires the use of trader's plates, or
 - (iii) to the nearest convenient registry for registration by the most direct or convenient route, or
 - (iv) for delivery at the address of a person who has acquired it from such a trader, or
 - (b) is being test driven by a prospective purchaser who is in possession of a written authorisation to drive the vehicle issued by the trader to whom the plate has been issued or by the trader's authorised employee or agent.
- (2) Nothing in subclause (1) authorises the use on a road or road related area of a registrable vehicle to which a trader's plate is affixed for the carriage of a load unless:
 - (a) the load is carried solely for the purpose of demonstrating to a genuine prospective purchaser the capacity of the vehicle for carrying a particular type of weight or loading, or
 - (b) the vehicle is being driven by the most direct or convenient route to the premises of the trader to whom the plate has been issued from the place at which the trader has manufactured or purchased the vehicle and the loading consists solely of a registrable vehicle manufactured or purchased by such a trader for sale by the trader, or
 - (c) the vehicle is a trailer specially constructed for the carriage of a boat and the loading consists solely of a boat, or

- (d) the vehicle weighs not more than 2 tonnes unladen and is being driven:
 - (i) by the shortest practicable route to the premises of the trader from the place at which the trader has manufactured or purchased the vehicle and the loading consists solely of goods that are intended for the trader's personal use or for use in his or her business as a trader, or
 - (ii) solely for carrying spare parts (being spare parts for use in connection with the repair of registrable vehicles by such a trader) to the trader's premises from a railway station or airport to which they have been consigned to the trader.
- (3) A person must not authorise an individual to test drive on a road or road related area an unregistered registrable vehicle to which a trader's plate is attached unless:
 - (a) the person is the trader to whom the trader's plate has been issued or is the trader's authorised employee or agent, and
 - (b) the person reasonably believes the individual to be a genuine prospective purchaser, and
 - (c) the person has made a record of the individual's name and address, and
 - (d) the person has provided the individual with a written authorisation to drive the vehicle.

Maximum penalty: 20 penalty units.

- (4) In this clause:
trader's authorised employee or agent means an employee or agent of the trader duly authorised in writing.

53 Trader to keep and produce record (cf 2007 reg cl 47)

A person to whom a trader's plate for a registrable vehicle is issued must:

- (a) in respect of each occasion on which a registrable vehicle is driven on a road or road related area with the plate affixed—cause particulars to be entered on a record in a form approved by the Authority, and
- (b) keep any such record at the premises in which the person carries on the business in respect of which the trader's plate was issued for at least 6 months after the record was made, and
- (c) produce any such record for the preceding 6 months for inspection when required so to do by the Authority or a police officer.

Maximum penalty: 20 penalty units.

54 Questions regarding use of plate to be answered (cf 2007 reg cl 48)

Any driver or person in charge of a registrable vehicle to which a trader's plate is affixed or any person to whom a trader's plate has been issued must, when required to do so by the Authority or a police officer, immediately answer truthfully all questions that are put to the person concerning the purpose for which the plate is used.

Maximum penalty: 20 penalty units.

55 Disposal or cessation of business (cf 2007 reg cl 49)

If a trader to whom a trader's plate has been issued sells, disposes of or ceases to carry on the business to which the trader's plate relates, the trader must, within 14 days, give written notification to the Authority of the sale, disposal or cessation of the business and deliver the trader's plate to the Authority.

Maximum penalty: 20 penalty units.

56 Return of trader's plate (cf 2007 reg cl 50)

- (1) If the Authority is satisfied that a person has ceased for any reason to be entitled to hold a trader's plate issued to the person, the Authority may request the person immediately to deliver the trader's plate to the Authority.
- (2) Subject to subclause (1), any person to whom a trader's plate has been issued must, not later than 14 days after the expiration of the period for which the trader's plate was issued, deliver the trader's plate to the Authority.
Maximum penalty: 20 penalty units.
- (3) A person must not drive, or allow to be driven, or be in charge of, any registrable vehicle on a road or road related area if there is affixed to or displayed upon the vehicle any trader's plate that was issued for a period that has expired.
Maximum penalty: 20 penalty units.

Division 3 Persons unaware of registration status

57 Vehicles being driven in the course of motor industry business (cf 2007 reg cl 50A)

- (1) For the purposes of section 68 (2) (b) of the Act, the use of an unregistered registrable vehicle on a road or on a road related area is permitted if the person using the vehicle:
 - (a) was not the responsible person for the vehicle at the relevant time, and
 - (b) was a motor industry business employee or owner using the vehicle in the course of motor vehicle dealing or the repair, inspection, maintenance, cosmetic enhancement or testing of the vehicle at the relevant time.
- (2) Subclause (1) does not apply if the person using the vehicle knew, or ought reasonably to have known, that the vehicle was unregistered at the relevant time.

58 Vehicles being driven by persons unaware of registration status (cf 2007 reg cl 50B)

For the purposes of section 68 (2) (b) of the Act, the use of an unregistered registrable vehicle on a road or on a road related area is permitted if the person using the vehicle:

- (a) was not the responsible person for the vehicle at the relevant time, and
- (b) did not know, and could not reasonably have known, that the vehicle was unregistered at the relevant time.

Part 5 Vehicle standards

Division 1 General requirements

59 Applicable vehicle standards (cf 2007 reg cl 51)

For the purposes of this Regulation, the *applicable vehicle standards* for a registrable vehicle are clause 25 and:

- (a) in the case of a light vehicle—the Light Vehicle Standards Rules, and

Note. See Schedule 2.

- (b) in the case of a heavy vehicle within the meaning of the *Heavy Vehicle National Law (NSW)*—the heavy vehicle standards within the meaning of that Law.

Note. See the *Heavy Vehicle (Vehicle Standards) National Regulation (NSW)*.

60 Registrable vehicles to comply with applicable vehicle standards (cf 2007 reg cl 52)

- (1) A person must not use a registrable vehicle on a road or road related area unless:

- (a) the vehicle complies with clause 25, and

- (b) in the case of a light vehicle:

- (i) the vehicle complies with the Light Vehicle Standards Rules, and

- (ii) the vehicle and its parts and equipment are suitable for safe use and are in a thoroughly serviceable condition.

Maximum penalty: 20 penalty units.

Note. Section 60 of the *Heavy Vehicle National Law (NSW)* makes it an offence for a person to use, or permit to be used, on a road a heavy vehicle that contravenes a heavy vehicle standard applying to the vehicle under that Law.

- (2) Without limiting the liability of any other person under subclause (1), if a registrable vehicle is used in contravention of that subclause by a person other than the registered operator of the vehicle, the registered operator is also guilty of an offence under that subclause.

- (3) A person is not guilty of an offence under subclause (1) if:

- (a) the vehicle concerned is used on a road or road related area in accordance with a condition imposed on its use, given expressly or by necessary implication, by a police officer or the Authority under section 76 of the Act, or

- (b) the vehicle:

- (i) fails to comply with the dimension limits prescribed by Division 2 of Part 6 of the Light Vehicle Standards Rules, and

- (ii) is exempt from the dimension limits by the operation of clause 141, or

- (c) the vehicle is conditionally registered under this Regulation despite a failure to comply with an applicable vehicle standard and is used on a road or road related area in accordance with the conditions of registration, or

- (d) the vehicle concerned is used on a road or road related area in accordance with the conditions of an unregistered vehicle permit.

- (4) If any person employed by the registered operator of a registrable vehicle that is a light vehicle to drive the vehicle becomes aware that the vehicle is not in a safe and thoroughly serviceable condition to be used on a road or road related area, the person must:

- (a) prepare, as soon as is practicable, in duplicate, a report on a form supplied to the person for that purpose by the registered operator that includes the prescribed particulars, and

- (b) retain a copy of the report and, as soon as is practicable:
 - (i) leave the other copy of the report with the registered operator, or
 - (ii) if it is not practicable for the registered operator personally to take delivery of the report—leave the report for the operator with a person, or at a place, appointed by the operator for the purpose.

Maximum penalty: 20 penalty units.

- (5) The registered operator of a registrable vehicle that is a light vehicle who employs a person to drive the vehicle must:
 - (a) provide the driver with forms for the purposes of subclause (4) and appoint a person with whom, or a place at which, any report referred to in that subclause may be left for the operator when it is not practicable for the registered operator to take delivery of it, and
 - (b) retain a copy of any report left with or for the registered operator under subclause (4) for a period of 6 months from the date of the report, and
 - (c) produce the report (or cause it to be produced) for inspection if required to do so by the Authority or a police officer.

Maximum penalty: 20 penalty units.

- (6) Nothing in subclause (4) or (5) affects the liability of any person under subclause (1) or (2).
- (7) In this clause:

prescribed particulars, in relation to a report referred to in subclause (4), means:

- (a) the date of the report, and
- (b) the registration number of the vehicle, and
- (c) a statement specifying which parts or equipment of the vehicle need, in the person's opinion, to be repaired, replaced or adjusted to put the vehicle in a safe and thoroughly serviceable condition.

registrable vehicle includes a road train and any component vehicle of a road train and a B-double.

road train means a combination, other than a B-double, consisting of a motor vehicle towing at least 2 trailers (counting as one trailer and a converter dolly supporting a semi-trailer).

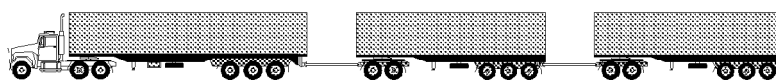

Road train

Division 2 Standards and certifications

61 Compliance with vehicle standards (cf 2007 reg cl 53)

- (1) The Authority may accept as evidence that a registrable vehicle complies with the applicable vehicle standards for the vehicle:
 - (a) an identification plate relating to the vehicle, or
 - (b) a certificate to that effect issued by the manufacturer of the vehicle, or
 - (c) the fact that the vehicle and the registered operator of the vehicle are the subject of a national maintenance accreditation, or

- (d) the fact that the vehicle and the registered operator of the vehicle are the subject of accreditation under a non-national maintenance accreditation scheme approved by the Authority.
- (2) In the absence of evidence mentioned in subclause (1), the Authority may, on inspecting the registrable vehicle, issue a certificate to the effect that the vehicle complies with the applicable vehicle standards for the vehicle.

62 Non-complying and non-standard vehicles (cf 2007 reg cl 54)

A registrable vehicle that does not comply with the applicable vehicle standards may be conditionally registered if the vehicle has:

- (a) an operations plate installed on it in accordance with this Division, or
- (b) a certificate of approved operations issued in accordance with this Division, or
- (c) an identification plate relating to the vehicle.

63 Operations plates and certificates of approved operations (cf 2007 reg cl 55)

- (1) The Authority may authorise a person to install an operations plate on, or issue a certificate of approved operations for, a registrable vehicle that has been manufactured or modified in such a way that the vehicle does not comply with the applicable vehicle standards for the vehicle.
- (2) An operations plate installed on, or a certificate of approved operations issued for, a registrable vehicle must indicate:
 - (a) any deficiencies in the vehicle's operating characteristics, and
 - (b) any conditions that should be applied to the vehicle's registration.

64 Modifications to registered light vehicles (cf 2007 reg cl 55A)

- (1) A person must not carry out modifications on a registered light vehicle (whether by the addition or removal of components or otherwise) that result in the vehicle failing to comply with the applicable vehicle standards.
Maximum penalty: 20 penalty units.
- (2) A light vehicle, or a modification to a light vehicle, is taken to comply with the applicable vehicle standards for the registered light vehicle if:
 - (a) the vehicle complies with the Authority standard compliance specifications, or
 - (b) the vehicle complies with those provisions of *Vehicle Standards Bulletin 14* that relate to the way in which the relevant modification is to be undertaken, or
 - (c) in the case of a street rod vehicle, the construction and any modification of the vehicle is in accordance with:
 - (i) the *National Guidelines for the Construction and Modification of Street Rods in Australia*, as published on the Authority's website, and
 - (ii) the NSW Supplement to the *National Guidelines for the Construction and Modification of Street Rods in Australia*, as published on the Authority's website.
- (3) However, if there is any inconsistency between the applicable vehicle standards and those specifications or provisions, or if those specifications or provisions are silent on a matter dealt with by the applicable vehicle standards, the light vehicle or modification must comply with the applicable vehicle standards.

Note. Section 85 of the *Heavy Vehicle National Law (NSW)* makes it an offence for a person to modify (or to use or permit the use on a road of) a heavy vehicle unless the modification has been approved by:

- (a) an approved vehicle examiner under section 86 of that Law, or
- (b) the National Heavy Vehicle Regulator under section 87 of that Law.

65 Construction of or modification to registered vehicles (cf 2007 reg cl 55B)

The Authority may publish guidance material on how a person may demonstrate that a vehicle complies with the applicable vehicle standards.

Division 3 Inspections

Subdivision 1 When vehicles may be inspected

66 Directed inspections (cf 2007 reg cl 56)

- (1) The Authority or a police officer may require a person to present a registrable vehicle for inspection by the Authority or an authorised examiner at a time and place specified in a notice in writing served on the person if:
 - (a) the person has control over the vehicle, or
 - (b) the vehicle is registered and the person is the registered operator of the vehicle.
- (2) A person on whom a notice under subclause (1) has been served may, not later than 24 hours before the time specified in the notice, request the Authority or police officer to change the time or place of inspection.
- (3) The Authority or police officer must consider any request made under subclause (2) and must, if it is reasonable to do so, notify the person of any change in the time or place of inspection.
- (4) A person must comply with:
 - (a) any notice served on the person under subclause (1), or
 - (b) any notification given to the person under subclause (3).Maximum penalty: 20 penalty units.
- (5) The Authority may require the registered operator of a registrable vehicle that is inspected pursuant to this clause to pay the applicable fee for the inspection.
- (6) Subclause (5) does not apply to any of the following vehicles if the inspection is carried out solely for the purpose of determining whether the vehicle's exhaust emission levels comply with this Regulation:
 - (a) a motor lorry with a GVM of 4.5 tonnes or more,
 - (b) an articulated motor lorry,
 - (c) a prime mover,
 - (d) a tow truck,
 - (e) a trailer,
 - (f) a bus or other vehicle equipped to seat more than 8 adult persons,
 - (g) a taxi.

67 Periodic inspections (cf 2007 reg cl 57)

- (1) Unless otherwise determined by the Authority, a registrable vehicle must be inspected by the Authority or by an authorised examiner:
 - (a) except as provided by paragraph (b), at least once every year, or
 - (b) in the case of a public passenger vehicle, at least twice every year.

- (2) In the case of a vehicle to be inspected by the Authority:
 - (a) the fees to accompany an application for the registration or renewal of registration of the vehicle must include:
 - (i) in the case of a public passenger vehicle, the applicable fees for 2 inspections of the vehicle, or
 - (ii) in any other case, the applicable fee for 1 inspection of the vehicle, and
 - (b) the date, time and place for an inspection of the vehicle is to be as agreed between the Authority and the registered operator of the vehicle, and
 - (c) unless otherwise determined by the Authority, if the vehicle is not presented for an inspection in accordance with such an agreement:
 - (i) the inspection fee for that inspection is forfeited to the Authority, and
 - (ii) if the vehicle is subsequently presented for inspection, a further inspection fee must be paid to the Authority before the vehicle is inspected.
- (3) An agreement referred to in subclause (2) (b) may be varied at the request of the registered operator of the vehicle so long as the request is made not later than 24 hours before the time currently agreed.

Subdivision 2 Authorised examiners and inspection stations

68 Examiner's authorities (cf 2007 reg cl 58)

- (1) The Authority may authorise in writing any person who, in its opinion, is suitably qualified and of suitable character:
 - (a) to conduct inspections and tests of registrable vehicles at authorised inspection stations for the purposes of determining whether or not the vehicles:
 - (i) are suitable for safe use, or
 - (ii) comply with the requirements of the Act and this Regulation, or
 - (iii) without limitation, comply with the requirements of the *Heavy Vehicle National Law (NSW)* and the regulations in force for the purposes of that Law, and
 - (b) to issue inspection reports relating to those inspections.
- (2) However, the Authority must not issue an examiner's authority to any person unless the person has undertaken, and has passed, a course of instruction for examiners that is approved by the Authority and conducted by an organisation approved by the Authority.
- (3) Without limiting subclause (1), an examiner's authority may be issued to authorise the holder of the authority to conduct inspections and tests referred to in subclause (1) at any place (other than on a road), but only in relation to any classes of heavy vehicles that are specified in the authority.
- (4) An examiner's authority may be subjected at any time to any conditions that the Authority may consider appropriate in relation to the person or class of persons concerned.
- (5) An examiner's authority:
 - (a) applies to the inspection of registrable vehicles generally or to the class or classes of registrable vehicles specified in the authority, and
 - (b) remains in force until it is surrendered, suspended or cancelled, and
 - (c) is to be issued in the manner and in the form approved by the Authority, and
 - (d) is subject to any condition imposed under this Subdivision.

- (6) An examiner's authority, or a duplicate of such an authority, must not be issued unless:
 - (a) the applicant for the authority or duplicate has paid the applicable fee for the issue of the authority, or
 - (b) the Authority has exempted the applicant from payment of that fee.
- (7) The charge that may be made for the issue of an inspection report referred to in subclause (1) must not be more than the maximum charge for the time being specified by the Authority.
- (8) A person who is not the holder of an examiner's authority must not:
 - (a) conduct an inspection or test of a registrable vehicle for the purpose of determining whether or not the vehicle is suitable for safe use or complies with the Act or this Regulation, or
 - (b) issue an inspection report relating to such an inspection.Maximum penalty: 20 penalty units.
- (9) The holder of an examiner's authority must not breach a condition of the authority.
Maximum penalty: 20 penalty units.
- (10) A person must not issue an inspection report if the person knows, or ought reasonably to suspect, that the report is false or misleading in a material particular.
Maximum penalty: 20 penalty units.
- (11) The Authority may exempt any person or class of persons from the requirement under subclause (2) to have undertaken, or to have passed, a course of instruction for examiners.

69 Proprietor's authorities (cf 2007 reg cl 59)

- (1) A person may be authorised in writing to use premises for the purpose of conducting inspections and tests of registrable vehicles by authorised examiners if the Authority is satisfied that:
 - (a) the premises and the equipment on the premises are suitable for that use, and
 - (b) the person is competent to carry out the responsibilities associated with using the premises for that purpose, and
 - (c) the person, and each person specified in the application for the proprietor's authority as being a person who will be involved in the use of the premises for that purpose, are of suitable character.
- (2) However, the Authority must not issue a proprietor's authority to any person unless the person has undertaken, and has passed, a course of instruction for proprietors that is approved by the Authority and conducted by an organisation approved by the Authority.
- (3) A proprietor's authority may be subjected at any time to any conditions that the Authority may consider appropriate in relation to the person or class of persons concerned.
- (4) A person must not use premises for the purposes of conducting an inspection or test referred to in subclause (1) unless the person is the holder of a proprietor's authority in force in respect of the premises.
Maximum penalty: 20 penalty units.
- (5) A person is not guilty of an offence under subclause (4) if the premises being used for the purposes of conducting an inspection or test are used in accordance with an authority issued under clause 68 (3).

- (6) A person who uses premises for the purposes of conducting an inspection or test referred to in subclause (1) must not permit an inspection report to be issued from those premises in relation to any such inspection or test if the person knows, or ought reasonably to suspect, that the report is false or misleading in a material particular.
Maximum penalty: 20 penalty units.
- (7) For the purposes of this Regulation, a licence in force under the *Motor Dealers and Repairers Act 2013* is taken to be a proprietor's authority issued in accordance with this clause.
- (8) A proprietor's authority:
 - (a) applies to the inspection of registrable vehicles generally or to the class or classes of registrable vehicles specified in the authority, and
 - (b) except in the case of a proprietor's authority that is a licence under the *Motor Dealers and Repairers Act 2013*:
 - (i) remains in force until it is surrendered, suspended or cancelled by the Authority, and
 - (ii) is to be granted, issued or refused (as the case requires) by the Authority and, if granted or issued, is to be in the manner and form approved by the Authority, and
 - (c) is subject to any condition imposed under this Subdivision.
- (9) A proprietor's authority (other than a proprietor's authority that is a licence under the *Motor Dealers and Repairers Act 2013*), or a duplicate of such an authority, must not be issued unless:
 - (a) the applicant for the authority or duplicate has paid to the Authority the applicable fee for the issue of the authority, or
 - (b) the Authority has exempted the applicant from payment of that fee.
- (10) The Authority may exempt any person or class of persons from the requirement under subclause (2) to have undertaken, or to have passed, a course of instruction for proprietors.

70 Authority may issue rules for the purposes of this Subdivision (cf 2007 reg cl 60)

- (1) The Authority may issue rules, not inconsistent with the Act or this Regulation, relating to all or any of the following:
 - (a) the inspection and testing of registrable vehicles to determine whether they are suitable for safe use or comply with the Act or this Regulation,
 - (b) the issue of inspection reports,
 - (c) the use of authorised inspection stations or other places for the purposes of conducting inspections or tests of registrable vehicles,
 - (d) the furnishing of information as to persons involved in:
 - (i) the conduct of inspections and tests of registrable vehicles at authorised inspection stations or other places, or
 - (ii) the use of authorised inspection stations or other places for the purposes of conducting such inspections and tests.
- (2) The Authority may, from time to time, alter any rules so issued.
- (3) It is a condition of an examiner's authority or a proprietor's authority that the holder of the authority comply with any rule in force under this clause issued to the person.

- (4) The Authority must issue a copy of the rules to any person who requests a copy, including an authorised examiner, or authorised proprietor, to whom a copy of the rules has been issued and who requests a further copy.
- (5) The Authority may require the payment of the applicable fee before issuing a copy or further copy of the rules, but may issue a copy without a fee in any particular case.

71 Books of inspection reports (cf 2007 reg cl 61)

The Authority may, on payment of any applicable fee, issue a book of inspection reports to the holder of a proprietor's authority.

72 Suspension or cancellation of examiner's authorities and proprietor's authorities

(cf 2007 reg cl 62)

- (1) The Authority may suspend or cancel an examiner's authority or a proprietor's authority (other than a proprietor's authority that is a licence under the *Motor Dealers and Repairers Act 2013*) if:
 - (a) the holder has failed to comply with a condition to which the authority is subject, or
 - (b) the Authority is, for any reason, of the opinion that the holder is not a fit and proper person to continue to hold the authority.
- (2) Without limiting subclause (1) (b):
 - (a) the Authority may form the opinion that the holder of an examiner's authority is not a fit and proper person to continue to hold the authority if it is satisfied that any person involved in the conduct of inspections and tests of registrable vehicles pursuant to the authority is not of suitable character, and
 - (b) the Authority may form the opinion that the holder of a proprietor's authority is not a fit and proper person to continue to hold the authority if it is satisfied that any person involved in the use of an authorised inspection station pursuant to the authority is not of suitable character.
- (3) The Authority cannot suspend or cancel an examiner's authority or a proprietor's authority unless:
 - (a) the Authority by notice in writing requests the person concerned to show cause why the authority should not be suspended or cancelled on the grounds specified in the notice, and
 - (b) that person replies to the notice or fails to reply within 21 days from the date the notice was issued.
- (4) Subclause (3) does not apply to the suspension of an examiner's authority or a proprietor's authority if the Authority has reason to suspect that the holder of the authority intentionally or recklessly contravened a rule in force under this Subdivision and is likely to commit further contraventions of the rules.

73 Committee of review (cf 2007 reg cl 63)

- (1) The Authority is to appoint a committee of review to which the Authority may refer for consideration and report to the Authority any case where consideration is being given to the refusal, suspension or cancellation of an examiner's authority or a proprietor's authority.
- (2) The committee of review is to include:
 - (a) a representative of the Authority, who is to be the chairperson of the committee, and

- (b) representatives of any organisations associated with trading in or servicing of registrable vehicles that the Authority considers appropriate.
- (3) The committee of review may determine its own procedure for dealing with cases referred to it by the Authority for consideration and report.
- (4) The committee of review must take into consideration any reply to a notice referred to in clause 72 (3) that is received by the Authority before the Authority refers the matter to which the notice relates to the committee.
- (5) The committee of review is to report to the Authority on any matter referred to it for consideration and must include in the report any recommendation that it wishes to make.
- (6) If members of the committee of review do not agree on the nature of a recommendation to be included in a report, the committee must record the disagreement in its report and may include in the report more than 1 recommendation.
- (7) In determining whether to suspend or cancel an examiner's authority or a proprietor's authority under this Subdivision, the Authority is to have regard to the report of the committee of review but is not bound to follow any recommendation included in the report.

74 Notification of decisions by Authority (cf 2007 reg cl 64)

- (1) If an application for the issue of an examiner's authority or a proprietor's authority is refused, or if an examiner's authority or proprietor's authority is suspended or cancelled by the Authority, the Authority must notify the applicant or holder of the authority in writing of the refusal, suspension or cancellation and of the grounds for it.
- (2) The decision of the Authority to suspend or cancel an authority has effect:
 - (a) on and from the date that is 21 days after the date on which the holder of the authority is notified, or
 - (b) if the holder appeals to the Local Court under Part 7.8 of the Act against the decision—subject to any orders of the Court and to the provisions of clause 135 of the *Road Transport (General) Regulation 2013*.
- (3) However, if the Authority has reason to suspect that the holder of an authority has intentionally or recklessly contravened a rule in force under this Subdivision and is likely to commit further contraventions of the rules, the decision of the Authority to suspend or cancel the authority may be expressed, in the instrument by which the holder is notified of the decision, to be effective on and from the date on which the holder is notified, and the decision has effect accordingly.
- (4) The date on which a holder is notified under this clause is:
 - (a) if the notice is sent by mail—the date when the notice would be delivered in the ordinary course of post, or
 - (b) if the notice is delivered to the holder personally—the date when it is delivered.
- (5) When a decision of the Authority to suspend or cancel an authority has effect, the holder must immediately deliver to the Authority any forms issued by the Authority in connection with the authority together with the authority itself.

Division 4 Component identification numbers

75 Definitions (cf 2007 reg cl 65)

In this Division:

component identification number, when used in relation to a part of a registrable vehicle, means the number and any accompanying letters or symbols stamped on or otherwise affixed to that part as a means of identifying the part (but does not include any casting number or any number used as a means of identifying a class of parts for manufacturing purposes).

vehicle part of a registrable vehicle means:

- (a) the engine of the vehicle, or
- (b) the engine block of the vehicle, or
- (c) in relation to a motor vehicle other than a motor bike—the chassis, chassis sub-frame or body of the vehicle, or
- (d) in relation to a motor bike—the frame or the crankcase of the motor bike.

76 Allotment of component identification numbers (cf 2007 reg cl 66)

- (1) The Authority may allot a component identification number for a vehicle part of a registrable vehicle if:
 - (a) there is no component identification number on the vehicle part of the vehicle or the component identification number of the vehicle part appears to have been altered, defaced, removed or obliterated, and
 - (b) the Authority is satisfied that such a number is necessary for the purpose of identifying the vehicle part.
- (2) The Authority may, by notice in writing, require the registered operator of the vehicle to have the number it has allotted to the vehicle part stamped on the vehicle part in the position specified in the notice.

77 Altering component identification numbers of vehicle parts without authority

(cf 2007 reg cl 67)

- (1) A person (other than a manufacturer) must not, without the written authority of the Authority and except in accordance with this Part, stamp or affix (or cause or permit any other person to stamp or affix) any component identification number on or to a vehicle part of a registrable vehicle.
- (2) A person must not alter, deface, remove or obliterate any component identification number stamped on or otherwise affixed to a vehicle part of a registrable vehicle otherwise than in accordance with this Part.
- (3) A person must not possess a vehicle part of a registrable vehicle knowing that the component identification number stamped on or otherwise affixed to the part has been altered, defaced, removed or obliterated otherwise than in accordance with this Part.

Maximum penalty: 20 penalty units.

78 Change or replacement of vehicle part (cf 2007 reg cl 68)

A person who changes or replaces a vehicle part of a registrable vehicle must:

- (a) notify the Authority of the change or replacement within 14 days of the change or replacement, and
- (b) specify the following in the notification:
 - (i) the date of the change or replacement,

- (ii) the registration number, if any, of the vehicle,
 - (iii) the name and address of the registered operator of the vehicle,
 - (iv) the make and component identification number of the vehicle part removed from the vehicle,
 - (v) the make and component identification number of the vehicle part substituted for the original vehicle part,
 - (vi) the name and address of the person from whom the substituted vehicle part was obtained, and
- (c) retain a copy of the notification in the person's possession for a period of 6 months, and
 - (d) produce a copy of any such notification for inspection if required to do so by the Authority or a police officer.

Maximum penalty: 20 penalty units.

79 Interference with component identification number (cf 2007 reg cl 69)

The registered operator of a vehicle may, if authorised in writing by the Authority, alter, deface, remove or obliterate any component identification number stamped on or otherwise affixed to a vehicle part of the vehicle.

Division 5 Vehicle defect notices issued under the Act

Note. For vehicle defect notices issued under the *Heavy Vehicle National Law (NSW)* in respect of heavy vehicles within the meaning of that Law, see Division 6 of Part 9.3 of that Law.

80 Issue of vehicle defect notices and formal warnings (cf 2007 reg cl 70)

- (1) A vehicle defect notice issued under the Act may be stated to be:
 - (a) a **major defect notice** if, in the reasonable opinion of the person issuing the notice, the further use of the registrable vehicle in road transport after the time specified in the notice would constitute an imminent and serious safety risk, or
 - (b) a **minor defect notice** if, in the reasonable opinion of the person issuing the notice, deficiencies in the registrable vehicle, if allowed to continue after the time specified in the notice, may:
 - (i) constitute a safety risk, or
 - (ii) hinder the ability of a person to identify the vehicle by reference to its number-plates.

Note. Section 76 of the Act provides that a police officer or the Authority may issue a vehicle defect notice under the Act.

Safety risk is defined in the Dictionary to mean danger to a person, to property or to the environment.

- (2) A vehicle defect notice issued under the Act must state:
 - (a) the registrable vehicle's registration details including the registration number, unregistered vehicle permit number (if practicable and applicable), expiry date and jurisdiction of registration, and
 - (b) the name of the driver of the registrable vehicle or, if the driver is not present when the notice is issued, the term "registered operator", and
 - (c) to the extent practicable, the registrable vehicle's identification details including its VIN, or if there is no VIN, the chassis number or engine number, its make and type, and
 - (d) the type of inspection conducted, and
 - (e) the details of the registrable vehicle's defects and whether the notice is a major defect notice or a minor defect notice, and

- (f) the time and date after which the registrable vehicle is not to be used on a road or road related area, and
 - (g) the means by which the registrable vehicle must be moved to another location following issue of the vehicle defect notice, and
 - (h) the repair requirement, including the date by which repairs must be completed if the vehicle is to be used on a road or road related area, and
 - (i) whether a penalty notice was also issued in relation to the defect at that time, and
 - (j) the name, official number or other identification of the person who issued the notice.
- (3) A person who issues a vehicle defect notice under the Act must:
- (a) in the case of a registrable vehicle the driver of which is present—give the driver the vehicle defect notice, and
 - (b) in the case of a registrable vehicle that is unattended—cause the vehicle defect notice to be affixed to the vehicle, and
 - (c) in the case of a major defect notice—cause a defective vehicle label to be affixed to the registrable vehicle.
- (4) A driver of a registrable vehicle (other than the registered operator of the vehicle) who is given a vehicle defect notice in accordance with subclause (3) must cause the notice to be sent to the registered operator of the vehicle.
Maximum penalty: 20 penalty units.
- (5) A defective vehicle label must state:
- (a) the registrable vehicle's registration number, and
 - (b) the time and date after which the registrable vehicle is not to be used on a road or road related area, and
 - (c) the means by which the registrable vehicle must be moved to another location following issue of the vehicle defect notice to which the label relates, and
 - (d) the name, official number or other identification of the person who issued the notice, and
 - (e) the date of issue of the label, and
 - (f) the serial number of the vehicle defect notice to which the label relates.
- (6) If a person who is entitled to issue a vehicle defect notice under the Act considers that deficiencies in a registrable vehicle should be remedied even though they do not constitute a safety risk or hinder the ability of a person to identify the vehicle by reference to its number-plates, the person may:
- (a) in the case of a registrable vehicle where the driver is present—give the driver a formal written warning, and
 - (b) in the case of a registrable vehicle that is unattended—cause the formal written warning to be affixed to the vehicle.
- (7) A driver of a registrable vehicle (other than the registered operator of the vehicle) who is given a formal written warning in accordance with subclause (6) must cause the warning to be sent to the registered operator of the vehicle.
Maximum penalty (subclause (7)): 20 penalty units.

81 Recording, clearance and withdrawal of vehicle defect notices (cf 2007 reg cl 71)

- (1) If a vehicle defect notice is issued under the Act, the Authority must record in the Register in relation to the vehicle:

- (a) the serial number of the vehicle defect notice, and
 - (b) the date (if any) shown on the notice for the clearance of the vehicle unless that date is later than the date of any recorded certificate of inspection.
- (2) The Authority may conduct, or require to be conducted, an inspection for the purposes of considering whether the defects described in a vehicle defect notice issued under the Act have been rectified and that the registrable vehicle does not have any other defects.
- (3) The Authority may require the registered operator of a registrable vehicle that is inspected pursuant to this clause to pay the applicable fee for the inspection.
- (4) A vehicle defect notice issued under the Act may be cleared by the Authority or an authorised person.
- (5) For the purposes of this Regulation, a vehicle defect notice issued under the Act is cleared when:
 - (a) the Authority receives evidence, in a form approved by the Authority, that the registrable vehicle is no longer defective, and
 - (b) in the case of a major defect notice—the Authority causes the defective vehicle label to be defaced or removed from the registrable vehicle.
- (6) A person must not deface or remove a defective vehicle label unless authorised to do so by the Authority.
Maximum penalty: 20 penalty units.
- (7) On the vehicle defect notice issued under the Act being cleared, the Authority must make a record in the Register to the effect that the vehicle defect notice has been cleared.
- (8) A person who issues a vehicle defect notice under the Act may withdraw that notice at any time and must cause:
 - (a) notice of the withdrawal to be sent to the person to whom the vehicle defect notice was issued, and
 - (b) a record to be made in the Register to the effect that the vehicle defect notice has been withdrawn.

Part 6 Certification of vehicles

Division 1 Preliminary

82 Definitions (cf 2007 reg cl 76AA)

- (1) In this Part:
 - certifier's licence* or *licence* means a certifier's licence in force under this Part.
 - compliance certificate* means a certificate issued in accordance with this Part.
 - inspect* a vehicle includes test a vehicle.
 - licensed certifier* means a person who holds a certifier's licence.
 - modification* of a vehicle includes the addition of components to, or the removal of components from, the vehicle.
- (2) Division 2 applies in relation to light vehicles only.
Note. See Part 3.3 of the *Heavy Vehicle National Law (NSW)* with respect to the modification of heavy vehicles within the meaning of that Law.
- (3) Division 3 applies in relation to light vehicles and heavy vehicles.

Division 2 Significantly modified vehicles

83 Significant modifications to vehicles (cf 2007 reg cl 76AB)

- (1) The Authority may declare a modification, or class of modifications, to a vehicle to be modifications to which this Division applies.
- (2) A declaration is to be made by order published in the Gazette and may be made only if the Authority is of the opinion that any such modification may pose a risk of harm to any person or affect the safe operation of a vehicle.

84 Modified vehicles not to be used unless certified (cf 2007 reg cl 76AC)

- (1) A person must not use a vehicle on a road or road related area and the registered operator or owner of the vehicle must not permit the vehicle to be used in such a way if the vehicle has had a modification to which this Division applies.
Maximum penalty: 20 penalty units.
- (2) A person does not commit an offence under subclause (1) if a compliance certificate has been issued in respect of the modification or in respect of the whole vehicle as modified and any such certificate has not been cancelled.

Division 3 Compliance certificates

85 Compliance certificate may be issued (cf 2007 reg cl 76AD)

- (1) A licensed certifier may issue a compliance certificate in a form approved by the Authority to the registered operator of a vehicle (or, if the vehicle is unregistered, to the owner of the vehicle).
- (2) A licensed certifier must not issue a compliance certificate in respect of a vehicle unless the certifier:
 - (a) holds a licence that permits the certifier to issue the particular compliance certificate, and
 - (b) has inspected the vehicle and has decided that:
 - (i) the vehicle complies with the applicable vehicle standards, or

- (ii) the particular modification to the vehicle to which the certificate relates does not cause the vehicle to fail to comply with the applicable vehicle standards.
- (3) For the purposes of subclause (2) (b), a light vehicle, or a modification to a light vehicle, that complies with the Authority standard compliance specifications or those provisions of *Vehicle Standards Bulletin 14* that relate to the way in which the relevant modification is to be undertaken is to be taken to comply with the applicable vehicle standards for the vehicle.
- (4) However, if there is any inconsistency between the applicable vehicle standards and the specifications or provisions referred to, or if those specifications or provisions are silent on a matter dealt with by the applicable vehicle standards, the light vehicle or modification must comply with the applicable vehicle standards for the purposes of subclause (2) (b).
- (5) A licensed certifier must not issue a compliance certificate if the certifier knows, or ought reasonably to suspect, that the certificate is false or misleading in a material particular.
- (6) A licensed certifier must pay to the Authority, within the time specified by the Authority, the applicable fee for each compliance certificate issued under this clause. Maximum penalty: 20 penalty units.

86 Authority may cancel compliance certificate (cf 2007 reg cl 76AE)

- (1) The Authority may, by notice in writing given to the registered operator of a vehicle (or, if the vehicle is unregistered, to the owner of the vehicle), cancel a compliance certificate that relates to the vehicle if, in the opinion of the Authority:
 - (a) the certificate was issued fraudulently, incorrectly or negligently, or
 - (b) the certificate is no longer relevant owing to subsequent modifications to the vehicle, or
 - (c) the vehicle no longer complies with the applicable vehicle standards.
- (2) The compliance certificate is cancelled at the time the notice is given or, if a later time is specified in the notice, at that later time.

87 Person may drive vehicle for purpose of compliance certificate (cf 2007 reg cl 76AF)

A person does not commit an offence under clause 60 (Registrable vehicles to comply with applicable vehicle standards), 84 (Modified vehicles not to be used unless certified) or the registration provisions (within the meaning of Schedule 1) in respect of a vehicle that is being driven:

- (a) to a licensed certifier for the purpose of obtaining a compliance certificate by the most direct and convenient route, or
- (b) in the course of the inspection of the vehicle by a licensed certifier, or
- (c) from any such inspection by the most direct and convenient route to the nearest place where work can be carried out on the vehicle to enable it to comply with the applicable vehicle standards, but only if the driver of the vehicle has notice in writing from the licensed certifier who inspected the vehicle that the vehicle does not pose an imminent risk to road safety.

Division 4 Licensing of certifiers

88 Definition (cf 2007 reg cl 76AG)

In this Division:

vary a licence includes imposing or revoking conditions to which the licence is subject or varying such conditions.

89 Applications with respect to licences (cf 2007 reg cl 76AH)

- (1) An individual may apply to the Authority for a certifier's licence or for the renewal or variation of such a licence.
- (2) An application must:
 - (a) be made in the manner and form approved by the Authority, and
 - (b) be supported by any information required by the Authority, and
 - (c) be accompanied by the applicable fee for the particular application, and
 - (d) in the case of an application for a renewal or variation of a licence, be made during the term of the existing licence.
- (3) The Authority is to decide an application by approving or refusing the application.
- (4) The Authority may, at its discretion, refuse an application on any ground.
- (5) The Authority must refuse an application for a licence or an application for a renewal of a licence if it is of the opinion that a person is not competent, or is not a fit and proper person, to hold a licence.
- (6) The Authority must give notice in writing to the applicant of its decision including, if the Authority decides to issue or renew a licence, the term of the licence.
- (7) If the Authority refuses an application the notice must specify the reasons for the refusal.

90 Licences (cf 2007 reg cl 76AI)

- (1) A certifier's licence is to be issued in the manner and form approved by the Authority and may be issued unconditionally or subject to conditions.
- (2) The term of a licence (unless cancelled or surrendered sooner) is the term of 1 year or any other period that may be specified by the Authority.
- (3) The Authority may, by notice in writing to the holder of a licence, cancel or suspend the licence or vary the licence or the term of the licence:
 - (a) if the holder has failed to comply with this Part, including any condition to which the licence may be subject under this Part, or
 - (b) if the holder is not, in the opinion of the Authority, competent to hold the licence, or
 - (c) if the holder is not, in the opinion of the Authority, a fit and proper person to hold the licence, or
 - (d) at its discretion on any other ground.
- (4) A variation, suspension or cancellation takes effect at the time the notice is given or, if a later time is specified in the notice, at that later time.
- (5) The holder of a licence must not breach a condition of the licence.
Maximum penalty: 20 penalty units.
- (6) The holder of a licence may surrender the licence at any time by notice in writing to the Authority.

91 Consultation before making certain decisions (cf 2007 reg cl 76AJ)

- (1) The Authority must not make a relevant licensing decision unless the Authority:
 - (a) gives the person concerned notice in writing of the grounds for the proposed decision, and
 - (b) requests in the notice that the person make a written submission, within 21 days, with respect to the proposed decision, and
 - (c) takes into account any submission received from the person within that 21-day period.
- (2) In this clause:

relevant licensing decision means a decision under this Part:

 - (a) to suspend or cancel a licence, or
 - (b) to refuse an application to renew a licence, or
 - (c) to impose or vary a condition on a particular licence (rather than on all licences).

92 Immediate suspensions (cf 2007 reg cl 76AK)

- (1) The Authority may suspend a licence immediately (an **immediate suspension**) without complying with clause 91 if the Authority is proposing to cancel the licence because it is of the opinion that the holder of the licence:
 - (a) has wilfully failed to comply with any requirement of this Part, including any condition to which the licence may be subject under this Part, or
 - (b) poses a risk to road safety if he or she continues to hold the licence.
- (2) After it imposes an immediate suspension, the Authority must, in respect of the proposed cancellation of the licence:
 - (a) give notice under clause 91 within 14 days, and
 - (b) make its final decision within 35 days after giving that notice (the **specified period**).
- (3) An immediate suspension remains in force with respect to a licence:
 - (a) if the Authority decides, within the specified period, to cancel the licence—until the licence is cancelled or, if the decision to cancel the licence is the subject of an appeal, until the Court overturns the decision or orders that the suspension should no longer remain in force, or
 - (b) if the Authority decides, within the specified period, not to cancel the licence—until that decision is made, or
 - (c) if the Authority makes no decision within the specified period—until the end of that specified period.

93 Record keeping requirements (cf 2007 reg cl 76AL)

- (1) The holder of a licence must keep a record of the following in respect of each inspection undertaken for the purposes of this Part:
 - (a) the following identification details of the vehicle on which the inspection was carried out:
 - (i) the registration number of the vehicle (if issued),
 - (ii) the vehicle identifier of the vehicle,
 - (iii) the make and model of the vehicle,
 - (iv) the build date or compliance date of the vehicle,
 - (b) a record of the methods and calculations used during the inspection,

- (c) the results of the inspection,
 - (d) a record of any compliance certificate issued as a result of the inspection.
- (2) A person who is required to keep a record under this clause must keep the record for at least 7 years after it is made.
- (3) A person who is required to keep a record under this clause must produce the record to the Authority or an authorised person when required to do so by the Authority or an authorised person.
- Maximum penalty: 20 penalty units.

94 Insurance (cf 2007 reg cl 76AM)

- (1) In this clause:
required insurance, in respect of a person, means professional indemnity insurance and public liability insurance that:
- (a) indemnify the person against any liability to pay compensatory damages arising from any act or omission of the person in the exercise of the functions of a licensed certifier under this Part, and
 - (b) satisfy any other requirements of the Authority that are set out in an order of the Authority that is published in the Gazette for the purposes of this clause.
- (2) A licensed certifier must not hold out that the licensed certifier is covered by the required insurance unless the licensed certifier is covered by the required insurance.
- Maximum penalty: 20 penalty units.
- (3) A person must be covered by:
- (a) the required insurance at all times that the person is a licensed certifier, and
 - (b) the required insurance that is professional indemnity insurance for at least 7 years after the person ceases to be a licensed certifier.
- Maximum penalty: 20 penalty units.
- (4) For the purposes of this clause, a person is taken to be covered by the required insurance if the person pays amounts specified by the Authority, at any times that the Authority may direct, towards insurance cover obtained by the Authority on behalf of the person.
- (5) A licensed certifier's licence is suspended:
- (a) at any time that the licensed certifier is not covered by the required insurance, and
 - (b) if the licensed certifier is relying on the insurance obtained by the Authority, at any time that there is an amount owing after the date payment is required under subclause (4).

95 Offence of holding out (cf 2007 reg cl 76AN)

- (1) A person must not issue a document that purports to certify to the registered operator or owner of a vehicle (for which a compliance certificate is required before the vehicle may be driven on a road or road related area) that the vehicle, or a modification to the vehicle, complies with the applicable vehicle standards unless the document is a compliance certificate.
- Maximum penalty: 20 penalty units.

- (2) A person must not purport to issue a compliance certificate or hold himself or herself out as a person who may issue such a certificate unless the person is the holder of a licence and the licence permits the person to issue the particular compliance certificate.

Maximum penalty: 20 penalty units.

96 Service of notices under Part (cf 2007 reg cl 76AO)

The date on which a person other than a registered operator is taken to have been given or served with a notice under this Part is:

- (a) if the notice is sent by mail—the fourth working day after the notice was posted, or
- (b) if the notice is delivered to the person personally—the date when it is so delivered.

Note. Clause 7 of the *Road Transport (General) Regulation 2013* makes similar provision in respect of notices given or served on registered operators.

Part 7 Written-off vehicles

Division 1 Preliminary

97 Definitions (cf 2007 reg cl 83A)

In this Part:

identification details, in relation to a vehicle, means the following:

- (a) whether the vehicle is a motor car, motor lorry, motor bike or trailer,
- (b) the registration number of the vehicle (if issued),
- (c) the vehicle identifier of the vehicle,
- (d) the make and model of the vehicle,
- (e) the shape of the vehicle,
- (f) the colour of the vehicle,
- (g) the variant of the vehicle,
- (h) the build date or compliance date of the vehicle,
- (i) the engine capacity of the vehicle,
- (j) the number of cylinders of the vehicle's engine,
- (k) the motive power of the vehicle,
- (l) the tare weight of the vehicle.

motor bike includes a motor trike.

motor car means a motor vehicle (except a motor bike) that is constructed principally for the conveyance of persons.

personal details of a person means all of the following:

- (a) the name and address of the person,
- (b) the telephone number (if any) of the person (unless the information is provided to the Authority electronically),
- (c) if the person has a customer number issued to it by the Authority and the information is provided to the Authority in paper form—the customer number of the person,
- (d) if the person is notifying the information on behalf of someone else and does not have a customer number or does not provide the information in paper form—the driver licence number of the person.

registration number of a vehicle includes, in the case of a vehicle the registration of which has expired or been suspended or cancelled, the registration number of the vehicle immediately before its registration expired or was suspended or cancelled.

relevant technical specifications in relation to a vehicle means the standards and methods of repair required to be met by a law of this State for vehicles of that type and:

- (a) the standards and methods of repair documented by the manufacturer of vehicles of that type, to the extent that they are relevant to ensuring the structural integrity and safety of the vehicle, or
- (b) where the manufacturer's documentation is unavailable, the standards and methods of repair recognised in the industry for vehicles of that type.

vehicle damage details, in relation to a vehicle, means the following:

- (a) whether the damage to the vehicle was caused by hail, water, impact, fire or stripping,

- (b) the location and severity of the damage to the vehicle described by reference to the codes or terms that are approved by the Authority from time to time.

98 Meaning of “written-off vehicle” (cf 2007 reg cl 83B)

For the purposes of paragraph (f) of the definition of *written-off vehicle* in section 83 (3) of the Act, a notifiable vehicle that has been assessed, in a vehicle damage assessment, as not being a total loss is prescribed if:

- (a) the vehicle has non-repairable damage and the insurer has decided not to repair the vehicle, or
- (b) the insurer has decided not to repair the vehicle and intends to sell, or has sold, the vehicle to a person other than the registered operator of the vehicle at the time the vehicle sustained the damage that resulted in it being presented for the vehicle damage assessment.

Division 2 Non-repairable damage

99 Non-repairable damage—vehicles other than motor bikes or trailers (cf 2007 reg cl 83C)

- (1) For the purposes of the definition of *non-repairable damage* in section 82 of the Act, the following are prescribed in respect of a vehicle (other than a motor bike or trailer):
 - (a) as a result of a fire, the vehicle has sustained a combination of damage to the exterior parts and interior parts of the vehicle,
 - (b) as a result of a fire, the paint on the vehicle has blistered on 3 or more of the primary structural features,
 - (c) the vehicle’s occupant cabin has been inundated with water (whether fresh or salt water) to a level exceeding the level of the inner door sill,
 - (d) the vehicle has been stripped of interior or exterior parts, panels or components or of a combination of interior and exterior parts, panels and components,
 - (e) the vehicle has damage to both longitudinal structural rails such that they require original equipment manufacture replacement, that is a replacement part that is:
 - (i) manufactured by the manufacturer of the vehicle to which it is being fitted, or
 - (ii) manufactured for the manufacturer of the vehicle to which it is being fitted, or
 - (iii) endorsed for use by the manufacturer of the vehicle to which it is being fitted,
 - (f) the vehicle has excessive structural damage.
- (2) For the purposes of this clause, a vehicle has *excessive structural damage* if 3 or more of the following damage indicators are present in the vehicle:
 - (a) any of the primary structural features of the vehicle has been fractured or cut or has buckled or folded over onto itself (where damage to each primary structural feature constitutes a separate damage indicator),
 - (b) due to a collision, damage has been sustained in respect of a suspension mount to the chassis or body of the vehicle, with each of the following constituting a separate damage indicator:
 - (i) if an independent suspension unit is damaged, damage to each station,
 - (ii) if a live axle is damaged, damage to the suspension on that axle,

- (c) due to a collision, any or all of the following mechanical components is cracked, deformed or broken:
 - (i) the engine block,
 - (ii) the transmission case,
 - (iii) the differential case,
 - (iv) the axle housing,
 - (d) the deployment or activation of any or all of the supplementary restraints (that is, airbags or seatbelt pretensioners).
- (3) For the purposes of calculating the number of damage indicators present in a vehicle:
- (a) each incidence of damage to a pillar or longitudinal structural rail or chassis is to be counted as a separate indicator, and
 - (b) each different and separate area of damage to the floor pan or firewall is to be counted as a separate indicator, and
 - (c) each incidence of structural damage to a suspension station is to be counted as a separate indicator except in the case of live axles, which are to be counted as a single indicator, and
 - (d) damage to any part of the roof is to be counted as a single indicator, and
 - (e) damage to any or all of the mechanical components is to be counted as a single indicator, and
 - (f) deployment or activation of any or all of the supplementary restraints (that is, airbags or seatbelt pretensioners) is to be counted as a single indicator.
- (4) In this clause:
- primary structural feature** of a vehicle means any of the following:
- (a) the roof,
 - (b) a pillar,
 - (c) the floor pan,
 - (d) a firewall,
 - (e) longitudinal structural rails or the chassis.

100 Non-repairable damage—motor bikes (cf 2007 reg cl 83CA)

For the purposes of the definition of **non-repairable damage** in section 82 of the Act, the following are prescribed in respect of a motor bike:

- (a) the motor bike has been burnt to such an extent that it is fit only for wrecking or scrap,
- (b) the motor bike has been stripped of all, or a combination of most, exterior body parts, panels and components (examples of which are the engine, wheels, and guards),
- (c) the motor bike has impact damage (excluding scratching) to the suspension and 2 or more areas of structural frame damage,
- (d) the motor bike has been fully immersed in salt water for any period,
- (e) the motor bike has been fully immersed in fresh water for more than 48 hours.

101 Non-repairable damage—trailers (cf 2007 reg cl 83CB)

- (1) For the purposes of the definition of **non-repairable damage** in section 82 of the Act, the following are prescribed in respect of a trailer:
- (a) the trailer has been burnt to such an extent that it is fit only for wrecking or scrap,

- (b) the trailer has been stripped of all, or a combination of most, interior and exterior body parts, panels and components,
 - (c) the trailer has impact damage (excluding scratching) to the suspension and 1 or more areas of structural frame damage,
 - (d) in relation to a trailer that is not a skeleton-type trailer or box trailer—the trailer has been fully immersed in salt water for any period,
 - (e) in relation to a trailer that is not a skeleton-type trailer or box trailer—the trailer has been fully immersed in fresh water for more than 48 hours.
- (2) In this clause:
skeleton-type trailer means a frame trailer that does not have a bottom or sides.

Division 3 Authorisations to repair

102 Vehicles that are not eligible for the issue of authorisation to repair (cf 2007 reg cl 83D)

For the purposes of section 85 (1) (b) of the Act, every notifiable vehicle other than the following is prescribed as a non-eligible vehicle:

- (a) a hail-damaged vehicle,
- (b) a vehicle that was inherited by the person seeking an authorisation to repair the vehicle,
- (c) a vehicle in respect of which the applicant for an authorisation to repair the vehicle was the registered operator of the vehicle for more than 28 days before the date on which the vehicle sustained the damage that resulted in it being presented for a vehicle damage assessment.

103 Eligibility to apply for an authorisation to repair (cf 2007 reg cl 83E)

For the purposes of section 85 (1) (c) of the Act, all persons other than the following persons are prescribed as non-eligible persons in relation to a vehicle:

- (a) the registered operator of the vehicle at the time the vehicle sustained the damage that resulted in it being presented for a vehicle damage assessment,
- (b) any person who has inherited the vehicle from the person who was the registered operator of the vehicle at the time the vehicle sustained the damage that resulted in it being presented for a vehicle damage assessment,
- (c) any person who intends to use the vehicle only to participate in motor sport activities approved by the Authority by order published in the Gazette.

104 Term of authorisations to repair (cf 2007 reg cl 83F)

- (1) An authorisation to repair remains in force for 12 months after its issue.
- (2) The Authority may extend the term of an authorisation at any time while it remains in force.

Division 4 Assessment of vehicles

105 Prescribed qualifications to carry out vehicle damage assessments (cf 2007 reg cl 83G)

- (1) For the purposes of section 90 (1) (a) of the Act, the prescribed training, qualifications and experience are all of the following:
 - (a) the successful completion of an approved course,

- (b) the demonstrated ability to determine whether or not a vehicle has suffered non-repairable damage,
 - (c) the demonstrated ability to apply each of the following:
 - (i) the relevant technical specifications, and
 - (ii) the written-off vehicle repair guidelines published in the Gazette by the Authority.
- (2) In this clause:
approved course means:
- (a) a training course in vehicle repair assessment provided by a training provider accredited by the Australian Skills Quality Authority, or
 - (b) a course that includes instruction on all of the following:
 - (i) the sourcing and interpretation of the standards and methods of repair documented by the manufacturers of vehicles or recognised in the industry for vehicles,
 - (ii) the use of those standards and methods in the calculation of repair costs,
 - (iii) the conduct of assessments of repairs in compliance with those standards and methods,
 - (iv) the assessment of vehicle damage having regard to the types of non-repairable damage that are prescribed by clause 99.

106 Standards of repairs and repair methods (cf 2007 reg cl 83H)

For the purposes of section 91 (b) of the Act, the standards of repairs, and the repair methods, prescribed in relation to a vehicle are the relevant technical specifications for the vehicle.

107 Records about vehicle damage assessments (cf 2007 reg cl 83I)

- (1) For the purposes of section 94 (1) (a) of the Act, the records that an assessor must keep in relation to each vehicle damage assessment made by or on behalf of the assessor are the following:
- (a) the identification details of the vehicle,
 - (b) details of the determination as to whether or not the vehicle has suffered non-repairable damage, including the date on which the determination was made,
 - (c) the name of the person who carried out the assessment,
 - (d) the reasons why the person who carried out the assessment was competent to do so,
 - (e) the sum for which the vehicle was insured,
 - (f) the market value of the vehicle and the basis for determining that value,
 - (g) the assessed cost of repairs and details of how the cost of repairs was determined, applying the relevant technical specifications,
 - (h) if the vehicle is not repaired by the assessor—the assessed salvage value of the vehicle and the basis for determining that value.
- (2) The Authority may, by notice in writing, exempt an assessor from any requirement to keep records that are specified in the notice.

Division 5 Notifications about written-off vehicles

108 Notification of information about vehicles assessed as a total loss (cf 2007 reg cl 83J)

The following information is prescribed as the information that must be provided under section 93 (1) of the Act to the Authority in respect of each notifiable vehicle that is assessed as being a total loss in the course of a vehicle damage assessment conducted by or on behalf of an assessor:

- (a) the identification details of the vehicle,
- (b) the vehicle damage details relevant to the vehicle,
- (c) the date on which the vehicle was determined to be a total loss by the assessor,
- (d) the personal details of the assessor and, if the information is notified by an agent of the insurer on behalf of the insurer, the personal details of the notifier,
- (e) the date on which the information is provided.

109 Notification of information about vehicles not assessed as a total loss (cf 2007 reg cl 83K)

- (1) This clause applies to a notifiable vehicle that has been assessed, in a vehicle damage assessment, as not being a total loss if:
 - (a) the vehicle has non-repairable damage and the insurer has decided not to repair the vehicle, or
 - (b) the insurer has decided not to repair the vehicle and intends to sell, or has sold, the vehicle to a person other than the registered operator of the vehicle at the time the vehicle sustained the damage that resulted in it being presented for a vehicle damage assessment.
- (2) An insurer must ensure that the Authority is provided with the following information concerning each notifiable vehicle to which this clause applies within 7 days after the decision is made not to repair the vehicle and before it is sold or disposed of:
 - (a) the identification details of the vehicle,
 - (b) the vehicle damage details relevant to the vehicle,
 - (c) the date on which the vehicle was determined not to be a total loss by the assessor,
 - (d) the personal details of the assessor and, if the information is notified by an agent of the insurer on behalf of the insurer, the personal details of the notifier,
 - (e) the date on which the information is provided.

Maximum penalty: 20 penalty units.

110 Prescribed information about vehicles disposed of to motor vehicle recycler

(cf 2007 reg cl 83L)

The following information is prescribed as the information that must be provided under section 93 (2) of the Act to the Authority in respect of each notifiable vehicle that is disposed of to a motor vehicle recycler by a self-insurer:

- (a) the identification details of the vehicle,
- (b) the vehicle damage details relevant to the vehicle,
- (c) the date on which the vehicle was disposed of to the motor vehicle recycler,
- (d) the personal details of the self-insurer and, if the information is provided to the Authority by another person, the personal details of that person,
- (e) the date on which the information is provided.

111 Prescribed information about demolished or dismantled vehicles (cf 2007 reg cl 83M)

The following information is prescribed as the information that must be provided under section 93 (3) of the Act to the Authority in respect of each notifiable vehicle that a motor vehicle recycler intends to demolish or dismantle:

- (a) the identification details of the vehicle,
- (b) the vehicle damage details relevant to the vehicle,
- (c) the date on which the motor vehicle recycler commenced, or intends to commence, work in the course of the motor vehicle recycler's business for the purpose of demolishing or dismantling the vehicle,
- (d) the personal details of the motor vehicle recycler and, if the information is provided to the Authority by another person, the personal details of that person,
- (e) the date on which the information is provided.

Division 6 Records about other vehicles

112 Records required to be kept by insurers of information about certain vehicles assessed as not being total losses (cf 2007 reg cl 83N)

- (1) An assessor who is an insurer is required to keep a register containing the following information in relation to each prescribed returned vehicle insured:
 - (a) the identification details of the vehicle,
 - (b) the vehicle damage details relevant to the vehicle,
 - (c) the date on which the vehicle was determined not to be a total loss by the assessor,
 - (d) the personal details of the person who carried out the assessment.Maximum penalty: 20 penalty units.
- (2) That register must be kept by the assessor for at least 7 years from the time of each entry.
Maximum penalty: 20 penalty units.
- (3) In this clause:
prescribed returned vehicle means a notifiable vehicle:
 - (a) that was the subject of a vehicle damage assessment, and
 - (b) that was assessed by its insurer as not being a total loss, and
 - (c) that the insurer has elected not to repair, and
 - (d) that is intended to be returned, or has been returned, by the insurer to the person who was its registered operator at the time the vehicle sustained the damage that resulted in it being presented for a vehicle damage assessment.

Division 7 Written-off vehicle warning labels

113 Obligation to attach written-off vehicle warning labels (cf 2007 reg cl 83O)

An assessor must ensure that a written-off warning label that complies with this Division is attached at all times to any vehicle in the assessor's possession or control that is prescribed as a written-off vehicle by clause 98:

- (a) to the part of the vehicle to which the vehicle identifier is attached (in the case of a dismantled vehicle), or

(b) to the vehicle (in any other case).

Maximum penalty: 20 penalty units.

Note. Section 97 of the Act requires a written-off vehicle warning label to be attached to certain vehicles that have been assessed to be a total loss. Not all written-off vehicles have been assessed as a total loss. This clause creates the same obligation in relation to written-off vehicles not assessed as a total loss.

114 Content and form of written-off vehicle warning label (cf 2007 reg cl 83P)

For the purposes of section 97 (1) of the Act, a written-off vehicle warning label on a vehicle must include the following:

Statutory written-off vehicle—available for parts or scrap only—limited exemptions apply.

115 Positioning of written-off vehicle warning label (cf 2007 reg cl 83Q)

For the purposes of section 97 (1) of the Act, a written-off vehicle warning label must be attached securely and in a conspicuous position where any person looking at the vehicle might be expected to see it, but not in a position that obscures the vehicle identifier.

116 Offence to alter, damage, destroy, remove or interfere with written-off vehicle warning label (cf 2007 reg cl 83R)

A person must not, without reasonable excuse, alter, damage, destroy, remove or otherwise interfere with a written-off vehicle warning label that has been attached to a vehicle under section 97 (1) of the Act or clause 113.

Maximum penalty: 20 penalty units.

Division 8 Certificates of compliance

117 Standards of repairs and repair methods (cf 2007 reg cl 83S)

For the purposes of section 98 (1) (b) of the Act, the standards of repairs, and the repair methods, prescribed in relation to a vehicle are the relevant technical specifications for the vehicle.

118 Certificates of compliance in relation to electronic control systems (cf 2007 reg cl 83T)

A licensed repairer is not authorised to issue a certificate of compliance in relation to electronic control systems (such as airbags or Anti-lock Braking Systems) unless the licensed repairer is approved by:

- (a) the manufacturer of the vehicle, or
- (b) the Authority.

119 Issue of certificates of compliance (cf 2007 reg cl 83U)

For the purposes of section 98 (1) (b) of the Act, a licensed repairer must not issue a certificate of compliance unless the repairs have been conducted in accordance with:

- (a) the relevant technical specifications, and
- (b) any written-off vehicle repair inspection guidelines published in the Gazette by the Authority that are in force.

Maximum penalty: 20 penalty units.

120 Term of certificates of compliance (cf 2007 reg cl 83V)

A certificate of compliance remains in force for 3 months after its issue, or for any other period approved by the Authority in a particular case.

121 Records of certificates of compliance (cf 2007 reg cl 83W)

A licensed repairer who issues a certificate of compliance, or who examines a vehicle for the purpose of determining whether or not to issue a certificate of compliance, must keep a record of the following in relation to each vehicle certified or examined:

- (a) the identification details of the vehicle,
- (b) the reference number of the authorisation to repair the vehicle issued by the Authority,
- (c) details of the assessment conducted by the licensed repairer for the purpose of determining whether or not to issue a certificate of compliance in relation to the vehicle,
- (d) details of the application in the assessment process of the relevant technical specifications and the written-off vehicle repair guidelines published in the Gazette by the Authority,
- (e) if the repair involved structural damage—the test report attesting to the structural integrity of the repaired vehicle,
- (f) the basis on which the licensed repairer formed an opinion that the vehicle should be issued with a certificate of compliance,
- (g) the date the certificate was issued.

Maximum penalty: 20 penalty units.

Division 9 Special provisions for certain vehicles

122 Vehicles returned to registered operator by insurer (cf 2007 reg cl 83Y)

- (1) In addition to the information required by clause 108, a certificate of compliance in relation to a vehicle is prescribed as the information that must be provided to the Authority in relation to a prescribed returned vehicle by an assessor who is an insurer under section 93 (1) of the Act.
- (2) For the purposes of section 93 (1) (b) of the Act, the information that is required to be provided to the Authority by section 93 of the Act, clause 108 and subclause (1) in relation to a prescribed returned vehicle must be provided within 15 days after the end of the quarter of the financial year in which the vehicle was the subject of a vehicle damage assessment.
- (3) A prescribed returned vehicle is taken not to be a written-off vehicle if the information required by subclause (1) has been provided to the Authority in relation to the vehicle within the period within which subclause (2) requires the information to be provided.
- (4) In this clause:
prescribed returned vehicle means a notifiable vehicle:
 - (a) that was the subject of a vehicle damage assessment, and
 - (b) that was assessed as being a total loss, and
 - (c) that has been repaired in accordance with the relevant technical specifications, and
 - (d) that is intended to be returned, or has been returned, by the insurer to the person who was its registered operator at the time the vehicle sustained the damage that resulted in it being presented for a vehicle damage assessment.

123 Hail-damaged vehicles (cf 2007 reg cl 83YA)

- (1) A *relevant written-off hail-damaged vehicle* means a notifiable vehicle:

- (a) that is assessed by an assessor as being a total loss solely due to hail damage, and
 - (b) that is retained by the person who was the registered operator of the vehicle for more than 28 days before the date on which the vehicle sustained the hail damage that resulted in it being presented for a vehicle damage assessment.
- (2) A relevant written-off hail-damaged vehicle is taken to be a former written-off vehicle for the purposes of Part 4.5 of the Act and is to be recorded in the NSW written-off vehicles register as such.
- (3) For the purposes of section 93 (1) (b) of the Act, the prescribed time within which an assessor must ensure that the Authority is provided with the information required to be provided under that paragraph in relation to a relevant written-off hail-damaged vehicle is the last day of the month in which the vehicle damage assessment was completed.

Part 8 Miscellaneous

Division 1 Fees, fee refunds and fee exemptions

124 Fees (cf 2007 reg cl 77)

- (1) The following fees are payable under this Regulation:
 - (a) fees prescribed by Schedule 3 for the various matters set out in that Schedule,
 - (b) fees fixed by the Authority under subclause (2),
 - (c) fees set by the Authority under clause 21 (Special number-plates).
- (2) The Authority may, with the approval of the Minister, fix fees to be payable for or in connection with any service provided by the Authority under the Act or this Regulation, except any service for which a fee is prescribed by Schedule 3.

Note. These fees are fixed under section 271 (1) of the Act and are required to be published in the Gazette.
- (3) Subclause (2) does not apply to fees set by the Authority under clause 21.

125 Refunds of fees (cf 2007 reg cl 78)

- (1) The Authority may make a partial refund of any applicable fee paid in respect of a registrable vehicle if:
 - (a) the Authority approves an application for the surrender of the registration of the vehicle, or
 - (b) the Authority cancels the registration of the vehicle and notification of that cancellation has been received by the registered operator of the vehicle.
- (2) For the purposes of subclause (1), a partial refund is to be calculated using the formula:

$$\frac{\text{number of days}}{\text{period of registration}} \times \text{fee}$$

where:

number of days is the number of unexpired whole days of the registration period of the vehicle, from the date on which the Authority approves an application for surrender made under clause 44 or cancels the registration of the vehicle concerned.

period of registration is the total number of whole days in the period for which the vehicle is registered.

fee is the amount of the applicable fee.

- (3) The Authority may refund (in whole or in part) any applicable fee paid by an applicant under clause 10 if the Authority is of the opinion that:
 - (a) the applicant was the registered operator of a registrable vehicle that was destroyed or rendered beyond repair as a consequence of damage caused to the vehicle by an occurrence that gave rise to an emergency, and
 - (b) the vehicle to which the application related was a replacement for the damaged vehicle, and
 - (c) in the circumstances of the case it would be appropriate to refund the fee.
- (4) The Authority may deduct from a refund of an applicable fee the amount of any unpaid fees incurred in respect of the vehicle.

- (5) If an amount of refund determined in accordance with subclause (2) would comprise an amount that is not a whole number of dollars, the amount of refund is to be adjusted downwards to the next whole number of dollars.
- (6) In this clause:
emergency has the same meaning as in the *State Emergency and Rescue Management Act 1989*.

126 Refunds of number-plate fees (cf 2007 reg cl 81)

The Authority may, in any case or class of cases that the Authority thinks it appropriate to do so, waive, reduce or refund (in whole or in part) any applicable fee payable or paid for or in connection with the issue, allocation, setting aside, reservation, transfer or replacement of a number-plate.

127 Exemption for eligible pensioners (cf 2007 reg cl 80)

- (1) A registrable vehicle that is owned solely by an eligible pensioner or jointly owned by 2 or more eligible pensioners is exempt from an administrative fee only if:
 - (a) it is not used in the course of any trade, business or profession or let out for hire, and
 - (b) it is used solely or principally by the pensioner or pensioners, and
 - (c) it is used substantially for social or domestic purposes or for pleasure, and
 - (d) it is a vehicle or a vehicle of a class or description of vehicles approved for the time being by the Authority.
- (2) An eligible pensioner is entitled to an exemption from administrative fees in respect of 1 vehicle only.
- (3) In this clause:
administrative fee means an applicable fee for the registration or renewal of registration of an eligible pensioner's registrable vehicle.

Division 2 Offences

128 Use of vehicle offences (cf 2007 reg cl 84)

- (1) A person must not use, or permit the use of, a registrable vehicle that is conditionally registered in contravention of a condition of registration.
Maximum penalty: 20 penalty units.
- (2) A person must not use, or permit the use of, a registrable vehicle in contravention of a defect notice.
Maximum penalty: 20 penalty units.
- (3) A person must not cause or permit another person to use an unregistered registrable vehicle (other than a vehicle that has had its registration suspended) on a road or road related area except as provided by Part 4.
Maximum penalty: 20 penalty units.
- (4) Subclause (3) does not apply in relation to the use of an unregistered registrable vehicle if the person causing or permitting the use of the vehicle does so in contravention of section 74 (1) of the Act.
- (5) A person must not cause or permit another person to use a registrable vehicle that has had its registration suspended on a road or road related area unless that use has been authorised by the Authority.
Maximum penalty: 20 penalty units.

- (6) For the purposes of section 68 (2) (b) of the Act, the use of a registrable vehicle on a road or road related area during any period in which its registration has been suspended by the Authority is permitted if that use has been authorised by the Authority.
- (7) For the purposes of section 81 (b) of the Act, subclauses (3) and (5) are prescribed.
Note. Section 81 of the Act provides for the seizure of number-plates.

129 Number-plate and registration certificate and label offences (cf 2007 reg cl 85)

- (1) The driver of a registrable vehicle is guilty of an offence if the vehicle is used on a road or in a road related area:
 - (a) with a number-plate affixed that was not issued by the Authority or was not issued for that vehicle, or
 - (b) with any registration label (that is required to be affixed to the vehicle) obscured, defaced, or otherwise not legible, or not displayed or affixed in accordance with this Regulation, or
 - (c) with a registration label that has expired (unless the vehicle is no longer required to have a registration label affixed).

Maximum penalty: 20 penalty units.

- (2) The driver of a registrable vehicle registered by the Authority is guilty of an offence if the vehicle is used on a road or road related area without displaying number-plates issued by the Authority for the purpose of authorising the use of the vehicle.

Maximum penalty: 20 penalty units.

- (3) The driver of a registrable vehicle is guilty of an offence if the vehicle is used on a road or in a road related area displaying:
 - (a) an altered number-plate or registration label, or
 - (b) the representation of a number-plate or registration label:
 - (i) other than a number-plate or registration label issued in accordance with this Regulation or another law, and
 - (ii) that is likely to be mistaken for a number-plate or registration label displayed in accordance with this Regulation, or
 - (c) an auxiliary number-plate otherwise than in accordance with clause 22 (4).

Maximum penalty: 20 penalty units.

- (4) The registered operator of a registrable vehicle (other than the driver of the vehicle) used in contravention of subclause (1), (2) or (3) is also guilty of an offence if the registered operator caused, permitted, allowed or failed to take reasonable precautions to prevent the contravention.

Maximum penalty: 20 penalty units.

- (5) This clause does not apply to:
 - (a) the use of trader's plates, or
 - (b) the use of a registered vehicle for the purpose of number-plate testing authorised by the Authority if the vehicle displays a sign indicating that number-plate testing is being carried out.

130 Notification offences (cf 2007 reg cl 86)

- (1) A person must provide notification to the Authority as required by this Regulation.
Maximum penalty: 20 penalty units.

- (2) Subclause (1) does not apply to a notification requirement under a provision of this Regulation for the contravention of which a maximum penalty is prescribed by the provision.
- (3) A person must not provide false or misleading information to the Authority about the location of the garage address of a registrable vehicle.
Maximum penalty: 20 penalty units.

Division 3 Disposal of forfeited vehicles

131 How forfeited vehicles may be disposed of under section 79 of the Act (cf 2007 reg cl 87)

- (1) For the purposes of section 79 (6) of the Act, a forfeited vehicle may be disposed of by public auction or public tender.
- (2) For the purposes of section 79 (6) of the Act, the vehicle may be disposed of otherwise than by sale if the Authority is satisfied on reasonable grounds that the vehicle has no monetary value or that the proceeds of sale would be unlikely to exceed the costs of sale.
- (3) If a forfeited vehicle offered for sale is not sold, the Authority may dispose of the forfeited vehicle otherwise than by sale.

132 Proceeds of sales of vehicles seized under section 79 of the Act (cf 2007 reg cl 88)

- (1) For the purposes of section 79 (7) of the Act, if a forfeited vehicle is sold in accordance with this Division, the Authority holds the net proceeds of sale (if any) of the vehicle for the person who was the owner of the vehicle immediately before its sale.
- (2) An application for payment of the net proceeds of sale may be made to the Authority at any time within 12 months after the forfeited vehicle was sold.
- (3) The Authority must pay the net proceeds of sale to the applicant if satisfied that the applicant is entitled to the proceeds.
- (4) If no application is made within that 12 month period, the Authority may transfer the net proceeds of sale to any of its funds that it considers appropriate. The money then becomes the property of the Authority.
- (5) In this clause:
net proceeds of sale means the proceeds (if any) of a sale of a forfeited vehicle remaining after deduction of:
 - (a) the expenses of sale and the fees and charges payable in respect of the impounding, holding and disposing of the vehicle under the *Impounding Act 1993*, and
 - (b) the fees, charges, taxes and fine, that the Authority could have allowed under section 79 (5) of the Act for the waiver of the forfeiture.

Division 4 Release of information by Authority

133 Release of information in Register to toll operators (cf 2007 reg cl 14A)

- (1) The Authority may enter into an agreement with a toll operator (a *registration information disclosure agreement*) that provides for the release to the toll operator of registration information with respect to a registrable vehicle.
- (2) The Authority must consult with the Privacy Commissioner before entering into a registration information disclosure agreement.

- (3) The Authority is authorised to release registration information in the Register in accordance with a registration information disclosure agreement.
- (4) A registration information disclosure agreement may provide for the payment of fees by a toll operator to the Authority in connection with the agreement, including fees for the release of information in accordance with the agreement.
- (5) In this clause:
registration information, with respect to a registrable vehicle, means the following information recorded in the Register:
 - (a) the name, residential address and address for the service of notices (if any) of any registered operator of the vehicle,
 - (b) the identification details of the vehicle.**toll operator** means a toll operator under the *Roads Act 1993*, other than the Authority.

134 Release of information of a personal nature (cf 2007 reg cl 14B)

- (1) Section 64 (3) of the Act does not prevent the release of information contained in the Register that is of a personal nature unless the privacy legislation would also prevent the particular release.
- (2) In this clause:
privacy legislation means the *Privacy and Personal Information Protection Act 1998* and the *Health Records and Information Privacy Act 2002* and any regulations or codes of practice under either of those Acts.

135 Release of information to Austroads (cf 2007 reg cl 14C)

- (1) The Authority is authorised to release any information in the Register to Austroads for the purposes of the National Exchange of Vehicle and Driver Information System.
- (2) In this clause:
Austroads means Austroads Limited (ACN 136 812 390), and includes any successor to or continuation of that company.

136 Release of information in Register to CTP insurers (cf 2007 reg cl 14D)

- (1) The Authority may enter into an agreement with a CTP insurer (a **CTP insurer registration information disclosure agreement**) that provides for the release to the CTP insurer of the relevant information about a registrable vehicle in connection with the following:
 - (a) the issue by that CTP insurer of a third-party policy in respect of the vehicle (including the provision of a quote for the issue of such a policy),
 - (b) the management (including cancellation) of a third-party policy issued by that CTP insurer in respect of the vehicle,
 - (c) the management of claims made under a third-party policy issued by that CTP insurer in respect of the vehicle (including the investigation of insurance fraud),
 - (d) the consistency of records held by the Authority and that CTP insurer in relation to third-party policies issued by that CTP insurer,
 - (e) the identification of the CTP insurer that is on risk in respect of the vehicle.**Note.** See section 13 of the *Motor Accidents Compensation Act 1999*.
- (2) The Authority is authorised to release relevant information in accordance with a CTP insurer registration information disclosure agreement.

(3) A CTP insurer registration information disclosure agreement may provide for the payment of fees by a CTP insurer to the Authority in connection with the agreement, including fees for the release of relevant information in accordance with the agreement.

(4) In this clause:

CTP insurer means a licensed insurer under the *Motor Accidents Compensation Act 1999*.

relevant information, with respect to a registered vehicle, means the following information:

- (a) any information recorded in the Register,
- (b) the date of birth of the registered operator (or any former or proposed registered operator) of the vehicle.

third-party policy means a third-party policy of insurance as defined under the *Motor Accidents Compensation Act 1999*.

137 Release of information for searches (cf 2007 reg cl 14E)

(1) The Authority is authorised to release vehicle information as part of the operation of a service that allows any person to conduct a search of information about the registration of a motor vehicle, whether or not for payment, including, but not limited to, the following:

- (a) the online service known as “Free registration check report” provided by the Authority,
- (b) the computer program designed to run on a smartphone or other mobile device known as the “Service NSW App”,
- (c) the online service known as the “Vehicle history report” provided by the Authority.

(2) In this clause:

CTP insurer means a licensed insurer under the *Motor Accidents Compensation Act 1999*.

vehicle information, with respect to a registrable vehicle, means the following information:

- (a) the registration number of the vehicle,
- (b) the month and year of manufacture of the vehicle,
- (c) the colour of the vehicle,
- (d) the make and model of the vehicle,
- (e) the variant of the vehicle,
- (f) the shape of the vehicle,
- (g) the last 4 characters of the vehicle identification number or chassis number of the vehicle,
- (h) the tare weight of the vehicle,
- (i) the gross vehicle mass of the vehicle,
- (j) the registration status of the vehicle (that is, whether it is current, cancelled or suspended),
- (k) the date on which the registration of the vehicle will expire,
- (l) whether a registration concession applies to the vehicle,
- (m) whether a registration restriction applies to the vehicle,

- (n) the date of first registration of the vehicle in New South Wales,
- (o) the written-off vehicle status of the vehicle,
- (p) the stolen vehicle status of the vehicle,
- (q) the odometer reading of the vehicle,
- (r) the number of current and previous New South Wales registered operators of the vehicle,
- (s) the registration usage history, including the usage type and period of use of the vehicle,
- (t) the last 4 characters of the engine number of the vehicle,
- (u) the third-party policy of insurance (as defined under the *Motor Accidents Compensation Act 1999*) applying to the vehicle and its end date,
- (v) the name of the CTP insurer of the vehicle,
- (w) the code of the CTP insurer of the vehicle.

138 Release of information in Register to Centrelink to verify concession entitlements

(cf 2007 reg cl 14F)

- (1) The Authority is authorised to release to Centrelink the relevant details of the registered operator of a registrable vehicle, or a person who has applied to be the registered operator of a registrable vehicle, for the purposes only of verifying whether or not the registered operator or proposed registered operator is eligible for a concession.
- (2) In this clause:
Centrelink includes any Commonwealth body that takes over the function of Centrelink.
relevant details of a person means the following details:
 - (a) the person's name,
 - (b) the person's date of birth,
 - (c) the customer reference number assigned to the person by Centrelink or the Commonwealth Department of Veterans' Affairs.

139 Release of information in Register to SIRA (cf 2007 reg cl 14G)

- (1) The Authority may enter into an agreement with SIRA (a **SIRA registration information disclosure agreement**) that provides for the release to SIRA of the relevant information with respect to a registrable vehicle for the purpose of enabling SIRA to exercise the functions conferred on it by section 24 of the *State Insurance and Care Governance Act 2015*.
- (2) The Authority is authorised to release the relevant information in accordance with the SIRA registration information disclosure agreement.
- (3) A SIRA registration information disclosure agreement may provide for the payment of fees by SIRA to the Authority in connection with the agreement, including fees for the release of relevant information in accordance with the agreement.
- (4) In this clause:
relevant information, with respect to a registrable vehicle, means the following information:
 - (a) any information recorded in the Register,
 - (b) the date of birth of the registered operator (or any former registered operator) of the vehicle.

SIRA means the State Insurance Regulatory Authority constituted under the *State Insurance and Care Governance Act 2015*.

140 Release of information to National Heavy Vehicle Regulator

The Authority is authorised to release any information in the Register to the National Heavy Vehicle Regulator established under section 656 of the *Heavy Vehicle National Law (NSW)*:

- (a) to assist the Regulator in exercising its functions under that Law, or
- (b) for any purpose related to the establishment of a scheme for the national registration of heavy vehicles.

Division 5 Other provisions

141 Application of Part 3A and clause 148 of Road Transport (General) Regulation 2013 (cf 2007 reg cl 90)

- (1) A vehicle is exempt from a dimension limit or any other requirement of this Regulation if the person or vehicle is exempt from that limit or requirement by or under a provision of Part 3A or clause 148 of the *Road Transport (General) Regulation 2013*.
- (2) In this clause:
dimension limit means a provision of this Regulation that limits or otherwise regulates the dimensions of any registrable vehicle (or any load or projection of the vehicle).

142 Special provisions relating to boat trailers (cf 2007 reg cl 91)

- (1) Any trailer constructed or that is being used for the conveyance of a boat is taken to comply with an affixing provision if the affixed item is securely affixed to a removable panel or panels constructed of wood, metal or other suitable material and the panel or panels are:
 - (a) while a boat is being carried on the trailer—securely affixed to the boat in such a manner that the affixed item is in a position and is facing in a direction which would comply with the provisions of this Regulation if the boat comprised part of the trailer, and
 - (b) while a boat is not being carried on the trailer—securely affixed to the trailer in such a manner that the affixed item is in a position and is facing in a direction which complies with the provisions of this Regulation.
- (2) In this clause:
affixed item, in relation to an affixing provision, means any number-plate, fitting for the number-plate, trader's plate, registration label, holder for a registration label, light, reflector or flashing light turn signal to which the affixing provision applies.
affixing provision means any provision of this Regulation relating to:
 - (a) the affixing of and any fitting for a number-plate or trader's plate or a registration label or a holder for such a label, or
 - (b) the affixing of and any fitting for any light, reflector or flashing light turn signal required or permitted by this Regulation to be fitted to the trailer.

143 Photographic evidence of unauthorised vehicle use: section 135 of Act (cf 2007 reg cl 91A)

The following offences against this Regulation are prescribed for the purposes of the definition of *unauthorised vehicle use offence* in section 135 (1) of the Act:

- (a) an offence against clause 56 (3),
- (b) an offence against clause 128 (3),
- (c) an offence against clause 128 (5).

144 Savings (cf 2007 reg cl 94)

- (1) Any act, matter or thing that, immediately before the repeal of the *Road Transport (Vehicle Registration) Regulation 2007*, had effect under that Regulation continues to have effect under this Regulation.
- (2) If a provision of this Regulation requires something to be done by or in relation to the registered operator of a registrable vehicle and there is more than one registered operator, the requirement applies to or in relation to each of the registered operators unless the Authority approves otherwise.

Note. Joint registration of vehicles is in the process of being phased out by the Authority.

Schedule 1 Application of Chapter 4 of Act and Regulation

Part 1 General

1 Definitions (cf 2007 reg Sch 1 cl 1)

In this Schedule:

registration provisions means the provisions of this Regulation concerning the registration of registrable vehicles (including the issue and use of number-plates and the use of unregistered vehicles).

2 Suspension of exemptions (cf 2007 reg Sch 1 cl 2)

The Authority may suspend, either indefinitely or for any period that it thinks fit, the operation of clauses 9 and 11 in relation to any registrable vehicle to which any of those clauses would, but for this clause, apply if, having regard to any of the matters referred to in clauses 45 (1), (2), (3) and (4) and 46 of this Regulation, the Authority considers such action desirable in the public interest.

3 Application of section 18 (1) of Act to Part 2 vehicles (cf 2007 reg Sch 1 cl 3)

- (1) The use of an unregistered registrable vehicle on a road or road related area is permitted under this Regulation for so long as the vehicle is a vehicle to which the registration provisions do not apply by reason of any provision of Part 2.
- (2) Without limiting subclause (1), such use of such a vehicle ceases to be permitted under this Regulation if at any time the registration provisions become applicable to the vehicle because the vehicle does not comply with an applicable condition or requirement of Part 2.

Note. Section 68 (1) of the Act makes it an offence for a person to use an unregistered registrable vehicle on a road. A vehicle is unregistered if it is not registered on the NSW registrable vehicles register. However, section 68 (2) (b) of the Act provides that section 68 (1) does not apply to the use of a registrable vehicle on a road if the use is otherwise permitted by the Act or under the statutory rules.

Part 2 Vehicles not subject to registration provisions

4 Vehicles on tow trucks (cf 2007 reg Sch 1 cl 4)

The registration provisions do not apply to a registrable vehicle under tow by a tow truck operating as a tow truck.

5 Vehicles used for work on farms (cf 2007 reg Sch 1 cl 5)

- (1) The registration provisions do not apply to:
 - (a) an agricultural implement towed by another vehicle, or
 - (b) a trailer towed by an agricultural machine operating as an agricultural machine.

- (2) In this clause:

agricultural implement means a vehicle without its own automotive power, built to perform agricultural tasks.

agricultural machine means a machine with its own automotive power, built to perform agricultural tasks.

Note. Examples of agricultural implements are irrigating equipment, augers, conveyors, harvester fronts, harvest bins and machinery fully carried on the three-point linkage of a tractor. Examples of agricultural machinery are tractors and harvesters.

6 Vehicles using roads or road related areas to a limited extent in context of primary production (cf 2007 reg Sch 1 cl 6)

- (1) The registration provisions do not apply to any registrable vehicle being driven across any road or road related area when travelling to or from land that is being used solely or mainly for the purpose of primary production.
- (2) In this clause:
primary production means any of the following:
 - (a) the cultivation of land for the purpose of selling the produce of the land,
 - (b) the maintenance of animals (including birds), whether wild or domesticated, for the purpose of selling them or their natural increase or bodily produce,
 - (c) commercial fishing or the commercial farming of fish, molluscs, crustaceans or other aquatic animals,
 - (d) the keeping of bees for the purpose of selling their honey or other apiary products,
 - (e) timber-getting for commercial purposes,
 - (f) mining for commercial purposes.

7 Certain trailers used for roadmaking and other public works (cf 2007 reg Sch 1 cl 7)

- (1) The registration provisions do not apply to any trailer that is hauled by a motor vehicle that is registered and is used solely:
 - (a) for the purposes of road construction, maintenance (including cleansing, sweeping, watering or any similar process) or repair, or
 - (b) on a public park or on land dedicated or reserved from sale by the Crown for public health, recreation, enjoyment or other public purposes of a like nature, or on land owned by or leased to or vested in a local council or the Crown, for rolling tennis courts, cricket wickets, lawns or pathways or improving the surface of the ground or for similar work, and not let out on hire,and which is used on any road or road related area solely while at, or proceeding to or returning from, the place where the road construction, maintenance or repair or other work is performed.
- (2) This clause does not apply to a trailer that is:
 - (a) a vehicle constructed, or used, primarily for the conveyance of any goods or materials, or
 - (b) a caravan being used for tours for recreation purposes.

8 Golf and green keeping vehicles (cf 2007 reg Sch 1 cl 8)

- (1) The registration provisions do not apply to any golf vehicle or green keeping vehicle being driven directly across a road or road related area that intersects with or traverses a golf course if the vehicle:
 - (a) is being used in the course of, or as an incident to, a game of golf or to observe any such game, or
 - (b) is proceeding to or from the golf course to be used for or in connection with the rolling or maintenance or surface improvement of any part of the golf course, or
 - (c) is proceeding to or from a car park or storage building that is separated from the golf course by the road or road related area.

(2) In this clause:

golf course means an area of land (which includes tees, fairways, greens, rough, pathways, bunkers and bridges) designed and used for the playing of golf.

golf vehicle means:

- (a) a motorised buggy or cart that is designed and used to carry any golfer, spectator or golfing equipment on a golf course, or
- (b) a motor bike having an engine capacity not exceeding 50 millilitres that is used to carry a golfer, spectator or golf equipment on a golf course, or
- (c) any trailer that is being drawn by any such vehicle.

green keeping vehicle means any vehicle used solely or principally for or in connection with the rolling or maintenance or surface improvement of any part of a golf course.

9 Vehicles temporarily in New South Wales (cf 2007 reg Sch 1 cl 9)

(1) The registration provisions do not apply to a registrable vehicle that:

- (a) is temporarily in New South Wales, and
- (b) is:
 - (i) registered in another State or Territory or in a foreign country, or
 - (ii) if unregistered—is permitted to be used in accordance with an interstate permit law or interstate trader's plate law, and
- (c) meets the requirements of subclause (2).

(2) The requirements to be met by a registrable vehicle referred to in subclause (1) are:

- (a) that the vehicle carries, conspicuously displayed in the required manner and condition, all number-plates and labels that the vehicle is at that time required, under a law of the vehicle's home jurisdiction, to carry in the home jurisdiction, and
- (b) that the vehicle complies with, and is used in accordance with, any conditions of registration (or any conditions of any permit or other authority) that apply in the vehicle's home jurisdiction, so far as they are capable of being applied to the vehicle, or use of the vehicle, outside the home jurisdiction.

(3) The registration provisions will apply to a registrable vehicle referred to in subclause (1) if at any time the vehicle does not comply with, or ceases to comply with, 1 or more of the requirements of subclause (2).

Note. For example, the registration provisions will apply to a registrable vehicle referred to in subclause (1) if the vehicle ceases to carry conspicuously displayed in the required manner and condition all number-plates and labels that it is at that time required to carry in the vehicle's home jurisdiction.

(4) In this clause:

home jurisdiction means:

- (a) in relation to a vehicle registered in another State or Territory or in a foreign country—that State, Territory or country, and
- (b) in relation to an unregistered vehicle permitted to be used in accordance with an interstate permit law or interstate trader's plate law of another State or Territory—that State or Territory.

interstate permit law means a law of another State or Territory that substantially corresponds to the provisions of this Regulation concerning unregistered vehicle permits.

interstate trader's plate law means a law of another State or Territory that substantially corresponds to the provisions of this Regulation concerning trader's plates.

10 Vehicles registered under the Interstate Road Transport Act 1985 (Cth) (cf 2007 reg Sch 1 cl 10)

The registration provisions do not apply to any registrable vehicle registered under the *Interstate Road Transport Act 1985* of the Commonwealth that has affixed to it a plate or compliance plate as required by the regulations made under section 13 (1) (a) of that Act:

- (a) while the vehicle is engaged in the *carriage of passengers or goods between prescribed places* within the meaning of that Act, or
- (b) while the vehicle is being driven or left standing for any purpose that is incidental to that carriage.

11 Trailers towed by motor vehicles registered in Victoria (cf 2007 reg Sch 1 cl 11)

The registration provisions do not apply to any trailer (other than a trailer used to carry a boat) that:

- (a) is being towed by a motor vehicle that is registered in Victoria, and
- (b) is exempt from registration in Victoria, and
- (c) is not used in the course of trade, and
- (d) weighs less than 200 kilograms unladen, and
- (e) has a manufactured width that does not exceed the width of the vehicle towing the trailer, and
- (f) is of a length (including the draw bar and any load) that does not exceed 3 metres, and
- (g) if it obscures the number-plate of that motor vehicle—displays (whether by painting or otherwise) on its rear the registration number of the vehicle so that the number is clearly distinguishable at a distance of 20 metres from the rear.

12 Vehicles used to fight rural fires (cf 2007 reg Sch 1 cl 12)

The registration provisions do not apply to any registrable vehicle that is used on a road or road related area if the vehicle:

- (a) is attached to a rural fire brigade formed under the *Rural Fires Act 1997* and has painted on it, or securely affixed to it, a sign clearly identifying the rural fire brigade to which it is attached, and
- (b) is used to convey persons or equipment to or from the work of preventing, mitigating or suppressing fires in rural fire districts (including clearing fire breaks or removing inflammable material), and
- (c) is travelling on the road or road related area for the purpose referred to in paragraph (b) or any of the following purposes:
 - (i) to attend a fire, incident or other emergency in accordance with the *Rural Fires Act 1997*,
 - (ii) to assist other emergency services organisations (within the meaning of the *State Emergency and Rescue Management Act 1989*) at incidents and at emergencies under the control of those organisations,
 - (iii) to convey persons or equipment for the purpose of training those persons in relation to any of the purposes referred to in this paragraph,
 - (iv) for a purpose necessary or incidental to the service or repair of the vehicle,

- (v) to perform any other functions of the NSW Rural Fire Service that the Commissioner of the NSW Rural Fire Service or a fire control officer within the meaning of the *Rural Fires Act 1997* may approve for the purposes of the exemption.

13 Vehicles used in connection with police work (cf 2007 reg Sch 1 cl 13)

The registration provisions do not apply to any registrable vehicle that is being used in connection with police work and to which is affixed a number-plate issued by the Authority for the purpose of being substituted for the number-plate that would otherwise be required to be affixed to the vehicle by this Regulation.

14 Lawn mowers (cf 2007 reg Sch 1 cl 14)

The registration provisions do not apply to any registrable vehicle, weighing not more than 250 kilograms when unladen, that is constructed or used solely for cutting grass or for purposes incidental to cutting grass.

15 Power-assisted pedal cycles (cf 2007 reg Sch 1 cl 15)

The registration provisions do not apply to any registrable vehicle that is a power-assisted pedal cycle within the meaning of vehicle standards, as amended from time to time, determined under section 7 of the *Motor Vehicle Standards Act 1989* of the Commonwealth other than 1 that has an internal combustion engine or engines.

Note. *Power-assisted pedal cycle* is defined in the *Vehicle Standard (Australian Design Rule – Definitions and Vehicle Categories) 2005* determined under section 7 of the *Motor Vehicle Standards Act 1989* of the Commonwealth. The definition of **power-assisted pedal cycle** includes pedalecs within the meaning of that Standard (which may have one or more auxiliary propulsion motors generating a combined power output not exceeding 250 watts).

16 Vehicles used by certain disabled persons (cf 2007 reg Sch 1 cl 16)

The registration provisions do not apply to any registrable vehicle that:

- (a) is specially constructed to be used, and while on a road or road related area is used, solely for the conveyance of a person with a disability that substantially impairs the person's mobility, and
- (b) cannot travel at over 10 kilometres per hour (on level ground).

17 Vehicles being driven to registration and associated places (cf 2007 reg Sch 1 cl 17)

- (1) The registration provisions do not apply to any registrable vehicle while it is being driven for the purpose of obtaining registration of the vehicle by the most direct or convenient route:
 - (a) to the nearest convenient registry, or
 - (b) to the nearest convenient vehicle inspection station or authorised inspection station to determine whether the registrable vehicle complies with the applicable vehicle standards for that vehicle, or
 - (c) in the course of inspection or testing of the motor vehicle for the purpose of making the determination referred to in paragraph (b), or
 - (d) to the nearest practicable weighbridge to determine the weight of the motor vehicle, or
 - (e) from a registry or from a vehicle inspection station or authorised inspection station where registration of the vehicle has been refused for any purpose to the nearest convenient place at which necessary repairs and adjustments to the vehicle may be effected or at which the vehicle may be garaged (except where the condition of the vehicle is such that a direction has been issued that the

vehicle must not be driven on a road or road related area before necessary repairs are effected), or

- (f) to the nearest convenient office of a licensed insurer within the meaning of the *Motor Accidents Compensation Act 1999* for the purpose of obtaining third party insurance for the vehicle in accordance with that Act, or
 - (g) to the nearest convenient location for any other purpose directly associated with the registration process.
- (2) The registration provisions do not apply to a registrable vehicle that:
- (a) is being driven for the purpose of obtaining an unregistered vehicle permit, and
 - (b) is proceeding by the most direct or convenient route to the nearest place at which a permit can be obtained under this Regulation,
- until it reaches that place.
- (3) In this clause, *direct or convenient route* includes the route to the nearest place at which the registrable vehicle can be weighed or inspected for the purpose of obtaining registration.

18 Vehicles that are being inspected (cf 2007 reg Sch 1 cl 18)

The registration provisions do not apply to any registrable vehicle the registration of which has expired but to which the number-plates are still affixed while the vehicle is being driven by an authorised examiner to determine whether the vehicle complies with the applicable vehicle standards for the vehicle.

Part 3 Vehicles to which Chapter 4 of Act does not apply

19 Light rail vehicles (cf 2007 reg Sch 1 cl 19)

Chapter 4 of the Act does not apply to any light rail vehicle.

20 Self-propelled elevating work platforms (cf 2007 reg Sch 1 cl 20)

- (1) Chapter 4 of the Act does not apply to a self-propelled elevating work platform.
- (2) In this clause:
self-propelled elevating work platform means a self-propelled vehicle used for construction, maintenance or warehouse operations that:
 - (a) is designed mainly for use otherwise than on a road or road related area, and
 - (b) is not capable of travelling at a speed in excess of 10 kilometres per hour, and
 - (c) is being used only for the purpose for which it is manufactured, and
 - (d) is not being used for transport on a road or road related area other than for the purposes of loading the vehicle onto another vehicle or unloading it from another vehicle or repositioning it at a work site.

Schedule 2 Light Vehicle Standards Rules

Note 1. This Schedule reproduces, with some modifications, national uniform legislation. A copy of the *Australian Light Vehicle Standards Rules 2015* on which this Schedule is based is available at www.pcc.gov.au.

Note 2. In addition to the standards set out in this Schedule, a light vehicle must also comply with clause 25 of this Regulation (see clause 59).

Note 3. For the standards that apply to heavy vehicles, see clause 25 of this Regulation and the *Heavy Vehicle (Vehicle Standards) National Regulation (NSW)*.

Part 1 Preliminary

1 Name of rules (cf ALVSR 2015 r 1)

These rules are the *Light Vehicle Standards Rules*.

2 Object of Light Vehicle Standards Rules (cf ALVSR 2015 r 2; 2007 reg Sch 2 cl 1)

- (1) The object of these rules is to set uniform Australian standards about the construction and performance of motor vehicles, trailers and combinations that are light vehicles.
- (2) The standards are intended:
 - (a) to promote, throughout the life of motor vehicles, trailers and combinations, their safe use and efficiency and the protection of the environment, and
 - (b) to reduce the cost of transport administration.

Part 2 Interpretation and application of the Light Vehicle Standards Rules

3 Definitions (cf ALVSR 2015 r 3; 2007 reg Dictionary)

- (1) In these rules:

adopted standard means a standard, except a national standard, that is adopted, applied or incorporated by these rules.

ADR means a national standard known as an Australian Design Rule.

air brake means an air-operated or air-assisted brake.

Air Services Act means the *Air Services Act 1995* of the Commonwealth.

Airservices Australia—see section 7 of the Air Services Act.

Airservices Australia vehicle means a vehicle driven by any of the following persons in the course of the person's duty to Airservices Australia:

- (a) the Chief Executive Officer of Airservices Australia appointed under section 34 of the Air Services Act,
- (b) a person appointed to act as Chief Executive Officer of Airservices Australia under section 41 of the Air Services Act,
- (c) a person employed under section 42 of the Air Services Act,
- (d) a person engaged as a consultant under section 43 of the Air Services Act.

Australian Border Force—see section 4 (1) of the *Australian Border Force Act 2015* of the Commonwealth.

Australian Border Force vehicle means a vehicle driven by an Immigration and Border Protection worker in the course of the worker's duty to the Australian Border Force.

Australian Standard means a standard approved for publication by Standards Australia.

Note. Copies of Australian Standards are available for purchase from Standards Australia at www.standards.org.au.

braking system, of a vehicle, means all the brakes of the vehicle and all the components of the mechanisms by which they are operated.

British Standard means a standard approved for publication on behalf of the British Standards Institution.

British Standards Institution means the institution of that name established under Royal Charter in the United Kingdom.

centre line, of an axle group, means:

- (a) if the group consists of 2 axles, one of which is fitted with twice the number of tyres as the other axle—a line located one third of the way from the centre line of the axle with fewer tyres, and
- (b) in any other case—a line located midway between the centre lines of the outermost axles of the group.

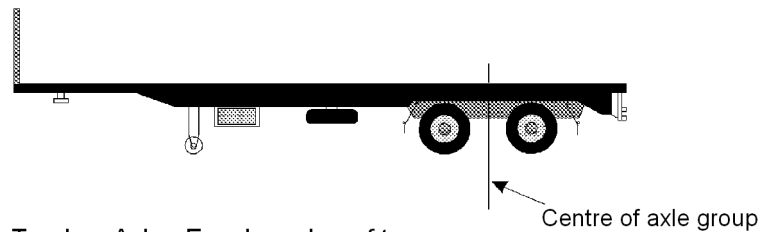

Tandem Axle - Equal number of tyres
Centre line of a tandem axle group fitted with an equal number of tyres on each axle

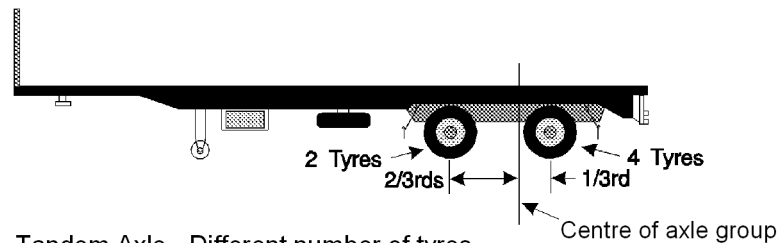

Tandem Axle - Different number of tyres
Centre line of a tandem axle group fitted with a different number of tyres on each axle

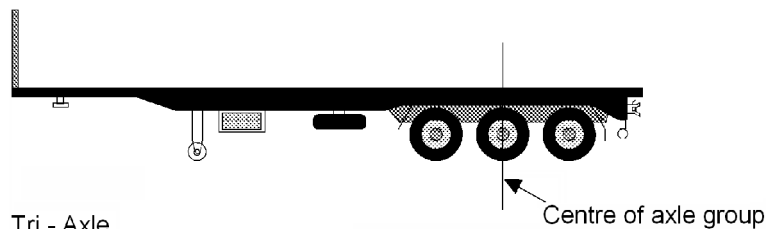

Tri - Axle
Centre line of a tri-axle group

clearance light means a light which, when lighted, provides an indication of the width of a vehicle together with any loading or equipment on it either from the front or from the rear of the vehicle, as the case may be.

daylight means the period in a day from sunrise to sunset.

emergency brake means a brake designed to be used if a service brake fails.

emergency vehicle means a vehicle driven by a person who is:

- (a) a police officer acting in the course of his or her duties as a police officer, or
- (b) a member of the Ambulance Service rendering or providing transport for sick or injured persons, or
- (c) a member of a fire brigade or rural fire brigade providing transport in the course of an emergency, or
- (d) a member of the State Emergency Service providing transport in the course of an emergency, or
- (e) a person (or person belonging to a class of persons) approved by the Authority.

exempt vehicle means:

- (a) an Airservices Australia vehicle, or
- (b) an Australian Border Force vehicle, or
- (c) an emergency vehicle, or
- (d) a police vehicle.

front fog light means a light used to improve the illumination of the road in case of fog, snowfall, heavy rain or a dust storm.

GTM (gross trailer mass) means the mass transmitted to the ground by the axles of a trailer when the trailer is loaded to its GVM and connected to a towing vehicle.

high-beam, in relation to a headlight or front fog light fitted to a vehicle, means that the light is built or adjusted so that when the vehicle is standing on level ground, the top of the main beam of light projected is above the low-beam position.

Immigration and Border Protection worker—see section 4 (1) of the *Australian Border Force Act 2015* of the Commonwealth.

light vehicle means a vehicle:

- (a) if the vehicle is a trailer—with an ATM of 4.5t or less, or
- (b) otherwise—with a GVM of 4.5t or less.

low-beam, in relation to a headlight or front fog light fitted to a vehicle, means that the light is built or adjusted so that, when the vehicle is standing on level ground, the top of the main beam of light projected is:

- (a) not higher than the centre of the headlight or fog light, when measured at a point 8 metres in front of the vehicle, and
- (b) not more than one metre higher than the level on which the vehicle is standing, when measured at a point 25 metres in front of the vehicle.

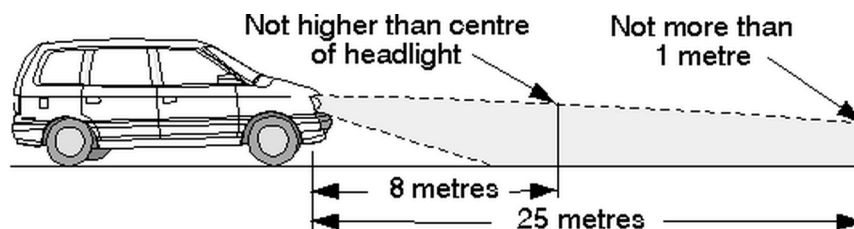

A headlight in the low-beam position

moped means a motor bike or trike with an engine cylinder capacity of not over 50 millilitres and a maximum speed of not over 50 kilometres an hour.

Motor Vehicle Standards Act means the *Motor Vehicle Standards Act 1989* of the Commonwealth.

mudguard means a fitting or device, with or without a mudflap, which is built and fitted to a vehicle in a way that will, as far as practicable, catch or deflect downwards

any stone, mud, water or other substance thrown up by the rotation of the wheel for which the fitting or device is provided.

national standard means a national standard under the Motor Vehicle Standards Act.

point of articulation means:

- (a) the axis of a kingpin for a fifth wheel, or
- (b) the vertical axis of rotation of a fifth wheel coupling, or
- (c) the vertical axis of rotation of a turntable assembly, or
- (d) the vertical axis of rotation of the front axle group or single axle of a dog trailer, or
- (e) the coupling pivot point of a semi-trailer.

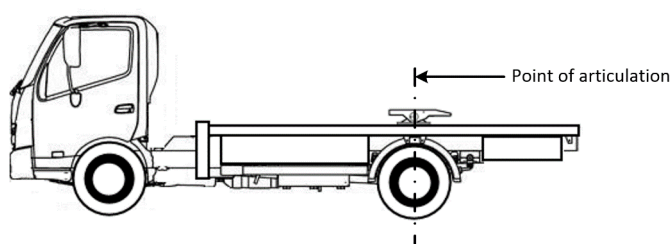

Point of articulation—fifth wheel on a prime mover

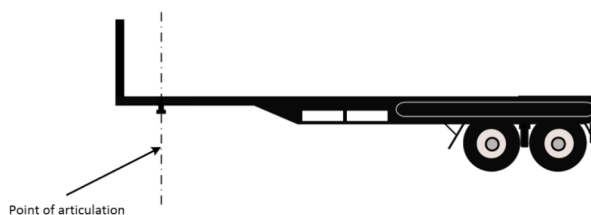

Point of articulation—kingpin for fifth wheel

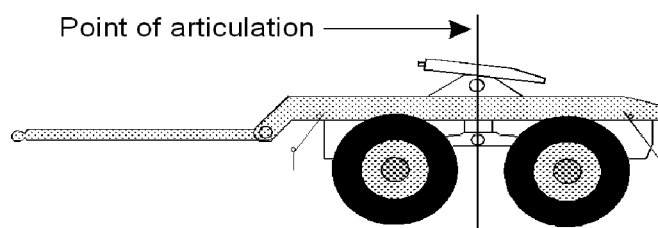

Point of articulation—fifth wheel coupling on a converter dolly (forming the front axle group of a dog trailer)

police vehicle means a vehicle driven by:

- (a) a member or special member of the Australian Federal Police, or
- (b) a member, however described, of the Police Force of a State or Territory, or
- (c) a service police officer within the meaning of the *Defence Force Discipline Act 1982* of the Commonwealth,

acting in the course of his or her duty.

second edition ADR means a national standard incorporated in the document described as the *Australian Design Rules for Motor Vehicle Safety, Second Edition* originally published by the then Commonwealth Department of Transport.

Standards Australia means Standards Australia Limited ACN 087 326 690, or any body to which Standards Australia Limited is a successor in law or that is a successor in law to Standards Australia Limited.

street vending vehicle means a motor vehicle or trailer used for the hawking of ice cream (including any form of frozen confection containing ice cream, flavoured ice, fruit-ice, water-ice or a substitute for ice cream) or chocolates, sweets or other confectionery.

third edition ADR means a national standard incorporated in the document described as the *Australian Design Rules for Motor Vehicles and Trailers, Third Edition* published by the Federal Office of Road Safety of the Commonwealth Department of Transport and Regional Services.

vacuum brakes means vacuum-operated or vacuum-assisted brakes.

VSB is the abbreviation for Vehicle Standards Bulletin.

Note. The Vehicle Standards Bulletins provide information on the design, manufacture, sale, modification, maintenance, import and repair of road vehicles. The term **road vehicles** includes both motor vehicles and trailers.

yellow includes amber.

- (2) The definitions in subrule (1) define certain words and expressions, and include signpost definitions to words and expressions defined elsewhere in these rules.

Note. A signpost definition (e.g. **vehicle**—see rule 4) is included in subrule (1) if the definition applies outside the rule defining the word or expression.

- (3) The definitions in subrule (1) are part of these rules.
- (4) A definition in these rules applies to each use of the word or expression in these rules, unless the contrary intention appears.
- (5) For the purposes of the definition of **national standard** in subrule (1), a reference in these rules to a national standard is a reference to the national standard as in force from time to time.

4 Application of Light Vehicle Standards Rules to light vehicles only (cf ALVSR 2015 r 4; 2007 reg Sch 2 cl 1A (1))

These rules apply to light vehicles only.

5 When restored vehicle is built (cf ALVSR 2015 r 5; 2007 reg Sch 2 cl 180 and Dictionary definition of “restored vehicle”)

- (1) In this rule:
restored vehicle means a vehicle that is being, or has been, restored to the vehicle’s manufacturer’s specifications, so far as it is practicable to meet the specifications.
- (2) For these rules, a restored vehicle is taken to have been built when the vehicle was originally built and not when the vehicle was restored.

6 Measurement of width of vehicles (cf ALVSR 2015 r 6; 2007 reg Sch 2 cl 32 (6), 64 (2), 71 (2), 93 (9), 94 (6), 103 (6), 112 (4), 122 (4))

For the purposes of these rules, the width of a vehicle is measured disregarding any of the following devices:

- (a) an anti-skid device mounted on the wheels of the vehicle,
- (b) a central tyre inflation system fitted to the vehicle,
- (c) any side marker light fitted to the vehicle,
- (d) any mirror fitted to the vehicle,
- (e) any reflector fitted to the vehicle,
- (f) any signalling device fitted to the vehicle,

- (g) any tyre pressure gauge fitted to the vehicle,
- (h) any permanently fixed webbing assembly-type device, if the maximum distance across the body of the vehicle, including any part of the device, is not more than 2.55 metres.

Example of permanent fixed webbing assembly-type device. A curtain-side device.

6A NSW rule: measurement of distance between parallel lines (cf 2007 reg Sch 2 cl 182)

For the purposes of these rules, a distance between 2 parallel lines is measured at right angles between the lines.

7 Australian Light Vehicle Standards Rule not reproduced (cf ALVSR 2015 r 7)

* * * * *

Note. Rule 7 (What is a road) of the *Australian Light Vehicle Standards Rules 2015* has not been reproduced in these rules because **road** is defined in section 4 (1) of the Act.

8 Australian Light Vehicle Standards Rule not reproduced (cf ALVSR 2015 r 8)

* * * * *

Note. Rule 8 (What is a road-related area) of the *Australian Light Vehicle Standards Rules 2015* has not been reproduced in these rules because **road related area** is defined in section 4 (1) of the Act.

9 Diagrams (cf ALVSR 2015 r 9; 2007 reg Sch 2 cl 5 (1))

- (1) A diagram in these rules is part of these rules.
- (2) A diagram of something is an illustrative example of the thing, but does not represent the thing's dimensions or the dimensions of any part of the thing.

10 Australian Light Vehicle Standards Rule not reproduced (cf ALVSR 2015 r 10)

* * * * *

Note. Rule 10 (Notes) of the *Australian Light Vehicle Standards Rules 2015* has not been reproduced in these rules because the status of notes in this Regulation is provided for by clause 3 (2) of this Regulation.

11 Examples (cf ALVSR 2015 r 11; 2007 reg Sch 2 cl 5 (2) and (3))

- (1) An example (whether or not in the form of a diagram) in these rules is part of these rules.
- (2) If these rules include an example of the operation of a provision of these rules:
 - (a) the example is not exhaustive, and
 - (b) the example does not limit, and may extend, the meaning of the provision, and
 - (c) the example and the provision are to be read in the context of each other and of the other provisions of these rules, but, if the example and the provision as so read are inconsistent, the provision prevails.

11A NSW rule: references to registration before the commencement of Act (cf 2007 reg Sch 2 cl 6)

A reference in these rules to the registration of a vehicle on a date occurring before the commencement of the Act is taken to be a reference to its registration under the *Road Transport (Vehicle Registration) Act 1997* (before its repeal) or any predecessor to that Act.

11B NSW rule: date of manufacture of vehicle (cf 2007 reg Sch 2 cl 7)

The date of manufacture of a registrable vehicle imported into Australia is, for the purposes of these rules, taken to be the date of entry of the vehicle into Australia if

an application is or was made in New South Wales on or after 1 January 1984 for registration of the vehicle as a public passenger vehicle.

11C NSW rule: optional items (cf 2007 reg Sch 2 cl 8)

If in a provision of these rules, a second edition ADR or a third edition ADR it is provided or indicated that any item of equipment is optional and the item is used on a registrable vehicle to which the provision is applicable, the item must conform with the requirements of that provision.

11D NSW rule: special requirements for vehicles used by disabled persons (cf 2007 reg Sch 2 cl 9)

The Authority may require that any registrable vehicle be specially constructed, equipped or adapted in a manner not provided for in these rules if:

- (a) it is to be used by a person who is suffering from a physical disability, or
- (b) it is to be used in any other circumstances that may be necessary in the interests of public safety.

11E NSW rule: Authority may exempt vehicle from requirement of Light Vehicle Standards Rules (cf 2007 reg Sch 2 cl 10)

- (1) The Authority may exempt any particular vehicle or class of vehicle from any requirement of these rules.
- (2) An exemption may be granted subject to conditions.
- (3) The Authority may amend or revoke an exemption or a condition made or imposed in accordance with this rule.

12 Australian Light Vehicle Standards Rule not reproduced

* * * * *

Note. Rule 12 (Application to vehicles and combinations on roads and road-related areas) of the *Australian Light Vehicle Standards Rules 2015* has not been reproduced in these rules. This rule has been left blank in order to preserve uniformity of numbering with the *Australian Light Vehicle Standards Rules 2015*.

13 Australian Light Vehicle Standards Rule not reproduced

* * * * *

Note. Rule 13 (Vehicles to which the Light Vehicle Standards do not apply) of the *Australian Light Vehicle Standards Rules 2015* has not been reproduced in these rules. This rule has been left blank in order to preserve uniformity of numbering with the *Australian Light Vehicle Standards Rules 2015*.

13A NSW rule: application of Light Vehicle Standards Rules (cf 2007 reg Sch 2 cl 2)

- (1) Subject to this rule and except where the context of these rules otherwise indicates or requires, a registrable vehicle that is a light vehicle and that is, or is to be, driven on a road or road related area:
 - (a) must be provided with the items of equipment appropriate for the vehicle set out in, and conforming with the provisions of, these rules, and
 - (b) must be so constructed and equipped that it will comply with all other provisions appropriate to the vehicle that are specified in these rules.
- (2) The provisions of these rules (other than this rule) do not apply to any plant that is not constructed on a chassis normally used in the construction of a motor lorry.
- (3) However, any such plant must comply with any vehicle standards or technical specifications approved by the Authority in relation to the plant.

(4) In this rule:

plant means a motor vehicle that wholly comprises:

- (a) a machine or implement that is not capable of carrying any load other than tools and accessories usually carried, or
- (b) a crane or a fork lift truck.

14 Non-application of Light Vehicle Standards Rules—exemption under other laws

(cf ALVSR 2015 r 14; 2007 reg Sch 2 cl 3)

- (1) A provision of these rules does not apply to a vehicle or combination if the vehicle or combination is exempt from:
 - (a) the provision under another law of this jurisdiction, or
 - (b) the corresponding provision of the law of another jurisdiction.
- (2) However, the vehicle or combination is exempt only if all conditions of the exemption (if any) are being complied with.

15 Australian Light Vehicle Standards Rule not reproduced

* * * * *

Note. Rule 15 (Application of Light Vehicle Standards to vehicle complying with inconsistent ADR requirement) of the *Australian Light Vehicle Standards Rules 2015* has not been reproduced in these rules. This rule has been left blank in order to preserve uniformity of numbering with the *Australian Light Vehicle Standards Rules 2015*.

16 Application to vehicle subject of Motor Vehicle Standards Act approval (cf ALVSR 2015 r 16; 2007 reg Sch 2 cl 4)

A provision of Parts 4 to 10 of these rules does not apply to a vehicle if:

- (a) the vehicle does not comply with a requirement of an ADR applying to the vehicle, and
- (b) the provision of these rules corresponds to the requirement of the ADR, and
- (c) despite the non-compliance, approval has been given, under subsection 10A (2) or (3) of the Motor Vehicle Standards Act, to place identification plates on vehicles of that type, and
- (d) the vehicle complies with the approval conditions (if any).

Note 1. Section 10A (2) of the Motor Vehicle Standards Act deals with vehicles that do not comply with an ADR, but the non-compliance is only minor and inconsequential.

Note 2. Section 10A (3) of the Motor Vehicle Standards Act deals with vehicles that do not comply with an ADR, and the non-compliance is not minor and inconsequential, but the vehicle will be safe to use if conditions are complied with.

17 Interpretation of certain second edition ADRs (cf ALVSR 2015 r 17; 2007 reg Sch 2 cl 183)

The words “left” and “right” in the following second edition ADRs have the opposite meaning in the application of the ADRs, in accordance with these rules, to a motor vehicle with a left-hand drive:

- (a) ADR 8 Safety Glazing Material,
- (b) ADR 14 Rear Vision Mirrors,
- (c) ADR 16 Windscreen Wipers and Washers,
- (d) ADR 18 Instrumentation,
- (e) ADR 35 Commercial Vehicle Brake Systems.

18 References to adopted standards (cf ALVSR 2015 r 18; 2007 reg Sch 2 cl 20 (1))

Unless the contrary intention appears, a reference in a rule or subrule to an adopted standard is a reference to the standard as in force when the rule or subrule commenced.

19 Compliance with particular adopted standards (cf ALVSR 2015 r 19; 2007 reg Sch 2 cl 19)

- (1) This rule applies if:
 - (a) a provision of these rules requires a vehicle, or a component of a vehicle, to comply with an adopted standard (the *replaced standard*), and
 - (b) the adopted standard has been replaced by a later adopted standard (the *later standard*).
- (2) The vehicle or component is taken to comply with the replaced standard if the vehicle or component complies with the later standard.

Example. A vehicle is taken to comply with the replaced standard AS 1973–1976 *Retreaded Pneumatic Passenger Car Tyres* if the vehicle complies with the later standard AS 1973–1993 *Pneumatic tyres—Passenger car, light truck, and truck/bus—Retreading and repair processes*.

20 Compliance with requirement to have particular equipment (cf ALVSR 2015 r 20)

A vehicle is taken to have equipment mentioned in these rules only if the equipment is in working order.

Part 3 Australian Design Rules

Division 1 Compliance with ADRs

21 Compliance with second edition ADRs (cf ALVSR 2015 r 21; 2007 reg Sch 2 cl 11)

- (1) If a second edition ADR recommends that the ADR should apply to the design and construction of a vehicle, the vehicle must comply with the ADR.
- (2) If a second edition ADR contains a requirement for a type of equipment fitted to a vehicle built on or after a stated time, any equipment of the same type fitted to the vehicle after it is built must comply with:
 - (a) the requirement as in force when the vehicle was built, or
 - (b) if the requirement is amended after the vehicle is built and before the equipment is fitted—the requirement as in force:
 - (i) when the vehicle was built, or
 - (ii) when the equipment was fitted, or
 - (iii) at any time between when the vehicle was built and the equipment was fitted.
- (3) However, a vehicle, or equipment fitted to a vehicle, need not comply with a recommendation or requirement of a second edition ADR if:
 - (a) the recommendation or requirement is replaced by, or is inconsistent with, a requirement of a third edition ADR applying to the vehicle or equipment, and
 - (b) the vehicle or equipment complies with the requirement of the third edition ADR.
- (4) If a second edition ADR allows a vehicle built on or after a stated time to be fitted with equipment, a vehicle built before that time may also be fitted with the equipment.

22 Compliance with third edition ADRs (cf ALVSR 2015 r 22; 2007 reg Sch 2 cl 12)

- (1) If a third edition ADR applies to the design and construction of a vehicle, the vehicle must comply with the ADR.
- (2) If a third edition ADR contains a requirement for a type of equipment fitted to a vehicle built on or after a stated time, any equipment of the same type fitted to the vehicle after it is built must comply with:
 - (a) the requirement as in force when the vehicle was built, or
 - (b) if the requirement is amended after the vehicle is built and before the equipment is fitted—the requirement as in force:
 - (i) when the vehicle was built, or
 - (ii) when the equipment was fitted, or
 - (iii) at any time between when the vehicle was built and the equipment was fitted.
- (3) However, a vehicle, or equipment fitted to a vehicle, need not comply with a requirement of a third edition ADR if:
 - (a) the requirement is replaced by, or is inconsistent with, a requirement of a later version of the ADR applying to the vehicle or equipment, and
 - (b) the vehicle or equipment complies with the requirement of the later version.
- (4) If a third edition ADR allows a vehicle built on or after a stated time to be fitted with equipment, a vehicle built before that time may also be fitted with the equipment.

Note. The following table contains a list of some terms used in the third edition ADRs and the corresponding term used in these rules.

Third edition ADRs	Light Vehicle Standards Rules
dipped-beam headlamp	low-beam (for a headlight)
front fog lamp	front fog light
rear fog lamp	rear fog light
wheelguard	mudguard
main-beam headlamp	high-beam (for a headlight)
reversing lamp	reversing light
direction indicator lamp	direction indicator light
stop lamp	brake light
rear registration plate lamp	number-plate light
front position (side) lamp	parking light
rear position (side) lamp	tail light
end-outline marker lamp	front or rear clearance light
external cabin lamp	external cabin light
internal lamp	interior light
side marker lamp	side marker light
daytime running lamp	daytime running light
rear reflex reflector, non-triangular	rear reflector
front reflex reflector, non-triangular	front reflector
side reflex reflector, non-triangular	side reflector

Division 2 Exemptions from compliance with ADRs

23 Vehicles that are not road vehicles (cf ALVSR 2015 r 23; 2007 reg Sch 2 cl 13)

A vehicle need not comply with an ADR applied by rule 21 (1) or 22 (1) if a determination or declaration under section 5B of the Motor Vehicle Standards Act provides that the vehicle is not a road vehicle for the purposes of that Act.

24 Vehicles subject to particular approvals etc. under Motor Vehicle Standards Act (cf ALVSR 2015 r 24; 2007 reg Sch 2 cl 14)

- (1) A vehicle need not comply with an ADR applied by rule 21 (1) or 22 (1) if:
 - (a) despite non-compliance with the ADR, approval has been given, under subsection 10A (2) or (3) of the Motor Vehicle Standards Act, to place identification plates on vehicles of that type, and
 - (b) the vehicle complies with the approval conditions (if any).

Note. See notes to rule 16.

- (2) A vehicle need not comply with an ADR applied by rule 21 (1) or 22 (1) if:
 - (a) the vehicle may be supplied to the market under section 14A (1) of the Motor Vehicle Standards Act, and
 - (b) for a vehicle for which an approval has been given under that subsection—the vehicle complies with the approval conditions (if any).
- (3) A vehicle need not comply with an ADR applied by rule 21 (1) or 22 (1) if:
 - (a) the vehicle may be used in transport in Australia under section 15 (2) Motor Vehicle Standards Act, and
 - (b) for a vehicle for which an approval has been given under that subsection—the vehicle complies with the approval conditions (if any).

25 Partial exception to compliance with ADRs—personally imported vehicles (cf ALVSR 2015 r 25; 2007 reg Sch 2 cl 15)

- (1) For this rule, a *personally imported vehicle* is a vehicle built after 1968 that is imported into Australia under regulation 13 of the *Motor Vehicle Standards Regulations 1989* of the Commonwealth by a person who owned and used the vehicle for a continuous period of at least:
 - (a) for a vehicle owned by the applicant before 9 May 2000—3 months, or
 - (b) in any other case—12 months,before it was imported into Australia.
- (2) A personally imported vehicle must be fitted with:
 - (a) seatbelts that are as effective as seatbelts that meet an Australian Standard or British Standard for seatbelts as in force on 29 June 1998, and
 - (b) seatbelt anchorages that meet the number and location requirements of second or third edition ADR 5, and
 - (c) child restraint anchorages that meet the number, location, accessibility, thread size and form requirements of second edition ADR 34 or third edition ADR 5 or 34, and
 - (d) head restraints that meet the number, location and size requirements of second or third edition ADR 22.
- (3) However, a personally imported vehicle need only meet the requirements of an ADR mentioned in subrule (2) if the ADR recommends that it should apply, or applies, to a vehicle of the same type.

- (4) A personally imported vehicle need not otherwise comply with an ADR applied by rule 21 (1) or 22 (1).

25A NSW rule: alteration of specifications (cf 2007 reg Sch 2 cl 16)

- (1) A car or motor car derivative must not be altered from its specifications, as originally manufactured, so that it no longer complies with the requirements of a second edition ADR or third edition ADR applicable to that vehicle or altered in any of the following respects:
- (a) by fitting a wheel rim that does not conform to the relevant dimensional standards for wheel rims set down in the Tyre and Rim Standards Manual issued by the Tyre and Rim Association of Australia,
 - (b) by widening the wheel track of the front or rear wheels by more than 25 millimetres beyond the maximum specified by the axle or vehicle manufacturer,
 - (c) by fitting a wheel nut that does not engage the thread of the wheel stud for at least the same length as the wheel nut provided by the vehicle manufacturer or by fitting a wheel nut that does not match the taper on the wheel stud hole,
 - (d) by fitting a tyre other than that appropriate to the wheel rim as specified in the Tyre and Rim Standards Manual issued by the Tyre and Rim Association of Australia or in any applicable second edition ADR or third edition ADR,
 - (e) so that any part of it other than a tyre or wheel rim will contact a road surface in the case of the complete deflation of a tyre,
 - (f) by welding or heating an axle, stub axle, steering arm or steering knuckle support.
- (2) A vehicle, other than a car or motor car derivative, must not be altered from its specifications, as originally manufactured, so that it no longer complies with the requirements of a second edition ADR or a third edition ADR applicable to that vehicle.
- (3) If a vehicle is altered from its specifications, as originally manufactured, the Authority may require the owner to supply any information about the alterations that the Authority considers necessary.
- (4) Despite subrules (1) and (2), a vehicle may be altered from its specifications as originally manufactured if the alteration only gives effect to any subsequent second edition ADR or third edition ADR applicable to a vehicle of that category.

25B NSW rule: compliance with third edition ADR as alternative to compliance with Light Vehicle Standards Rules (cf 2007 reg Sch 2 cl 17)

Nothing in Parts 4 to 11A prevents a registrable vehicle from being constructed and equipped so as to comply with any relevant requirement of a provision of a third edition ADR as an alternative to being constructed and equipped to comply with any relevant requirements of a corresponding provision of Parts 4 to 11A.

Part 4 General safety requirements

Division 1 All vehicles

25C NSW rule: general requirement to keep vehicles in good order (cf 2007 reg Sch 2 cl 21)

In addition to complying with the requirements of these rules, the weight of any registrable vehicle and everything in its construction, form, equipment, working and general condition must be such that:

- (a) it will not contravene any provision of any Act or other law, and
- (b) it will not cause danger or unreasonable annoyance to any person.

26 Steering (cf ALVSR 2015 r 26; 2007 reg Sch 2 cl 22)

- (1) A motor vehicle must have a right-hand drive if the vehicle:
 - (a) is less than 30 years old, and
 - (b) is required under a law of this jurisdiction to have a right-hand drive.
- (2) A motor vehicle has a right-hand drive if the centre of at least 1 steering control of the vehicle is to the right of, or in line with, the centre of the vehicle.
- (3) A component of the steering system of a motor vehicle that is essential for effective steering of the vehicle must be built to transmit energy by mechanical means only.
- (4) Failure of a non-mechanical component of the steering system must not prevent effective steering of the vehicle.
- (5) This rule does not apply to a vehicle if the vehicle is built mainly for a purpose other than the transport of goods or people by road.

27 Turning ability (cf ALVSR 2015 r 27; 2007 reg Sch 2 cl 23)

- (1) A motor vehicle must be able to turn in a circle not over 25 metres in diameter, measured by the outer edge of the tyre track at ground level.
- (2) The vehicle must be able to comply with subrule (1) whether it turns to the left or to the right.

28 Ability to travel backwards and forwards (cf ALVSR 2015 r 28; 2007 reg Sch 2 cl 24)

A motor vehicle with an unloaded mass over 450 kilograms must be able to be driven both backwards and forwards when the driver is in the normal driving position.

29 Protrusions (cf ALVSR 2015 r 29; 2007 reg Sch 2 cl 25)

- (1) An object fitted to a vehicle must be designed, built and fitted to the vehicle in a way that minimises the likelihood of injury to a person making contact with the vehicle.
- (2) However, subrule (1) does not apply to an object fitted to a vehicle if:
 - (a) the vehicle was designed before 1965 and the object was part of the design of the vehicle, or
 - (b) the object was fitted to the vehicle before 1965 in accordance with the law of the place where the object was fitted.
- (3) A vehicle frontal protection system that is fitted on a motor vehicle that:
 - (a) has a GVM not over 3.5 tonnes, and
 - (b) is manufactured on or after 1 January 2003,must comply with AS 4876.1–2002 *Motor vehicle frontal protection systems—Road user protection* (except clause 3.2).
- (4) Subrule (3) does not apply to a vehicle frontal protection system fitted on a motor vehicle if the model of the vehicle is a model of a kind manufactured before 1 January 2003.
- (5) In this rule:
vehicle frontal protection system means a structure fitted to the front of a vehicle to reduce damage to the vehicle structure and systems in the event of either a front-end impact or an animal strike.

Note. Examples of vehicle frontal protections systems are bullbars, roobars and nudge bars. Vehicle frontal protection systems may be fitted in front of, or in place of, vehicle bumpers.

29A NSW rule: oil and grease not to be dropped (cf 2007 reg Sch 2 cl 26)

All parts and fittings of a motor vehicle or trailer must be such that an undue amount of oil or grease will not be dropped onto the roadway.

30 Driver's view and vehicle controls (cf ALVSR 2015 r 30; 2007 reg Sch 2 cl 27)

A motor vehicle must be built:

- (a) to allow the driver a view of the road and of traffic to the front and sides of the vehicle so the driver can drive the vehicle safely, and
- (b) with its controls located so the driver can drive the vehicle safely.

31 Seating (cf ALVSR 2015 r 31; 2007 reg Sch 2 cl 28)

A seat for a driver or passenger in a vehicle must be securely attached to the vehicle.

31A NSW rule: seatbelts for cars registered between 1 January 1965 and 1 January 1969 (cf 2007 reg Sch 2 cl 29)

Every car and motor car derivative first registered on or after 1 January 1965 and before 1 January 1969 must be equipped for each front seat position that is adjacent to the side of the vehicle with a seatbelt that:

- (a) has been installed in accordance with instructions issued by the manufacturer of the seatbelt, and
- (b) at the time of its installation has not previously been installed and used in a motor vehicle, and
- (c) is of:
 - (i) a type referred to in Australian Standard AS E35/BWG–1966 *Drawings for bollard type webbing grips for testing car seat belt webbing* as a Combination Belt (High) and has been manufactured in accordance with that Standard, or
 - (ii) some other type approved by the Authority.

31B NSW rule: child restraint anchorage bolts in drive yourself vehicles (cf 2007 reg Sch 2 cl 30)

- (1) Every motor vehicle that is a drive yourself vehicle must be fitted with a child restraint anchorage bolt of a type approved by the Authority.
- (2) A child restraint anchorage bolt referred to in this rule must be fitted to a child restraint anchorage point if the vehicle is one required by the second edition ADRs or third edition ADRs to have a child restraint anchorage.
- (3) In this rule:

drive yourself vehicle means a motor vehicle that is let for hire (other than under a hire purchase agreement) without the services of a driver and that does not stand in a public street for hire, other than a motor cycle, a trailer or a motor vehicle that:

- (a) is used in connection with the work of any hospital or charitable, benevolent or religious institution by or on behalf of the authority controlling that hospital or institution, and
- (b) is operated in connection with a community transport project approved by the Minister.

31C NSW rule: door latches and hinges (cf 2007 reg Sch 2 cl 31)

Door latches and hinges on every vehicle must be so constructed that the doors are securely affixed to the vehicle and capable of remaining securely fastened when closed.

32 Mudguards (cf ALVSR 2015 r 32; 2007 reg Sch 2 cl 32)

- (1) A vehicle must have firmly fitted a mudguard for each wheel or for adjacent wheels.
- (2) However, subrule (1) does not apply to a vehicle if:
 - (a) the construction or use of the vehicle makes the fitting of mudguards unnecessary or impracticable, or
 - (b) the body or part of the body of the vehicle acts as a mudguard.
- (3) A mudguard fitted to a vehicle must, when the wheels of the vehicle are in position to move straight ahead:
 - (a) reduce the danger of a person contacting the moving wheels, and
 - (b) for the rear wheels:
 - (i) cover the overall tyre width of the wheel or wheels to which it is fitted, and
 - (ii) be fitted so the height above ground level of the lowest edge of the rear of the mudguard is not over one-third of the horizontal distance between the edge and the centre of the rearmost axle.
- (4) However, a mudguard may be up to:
 - (a) 230 millimetres above ground level, or
 - (b) on a vehicle built to be used off-road—300 millimetres above ground level.
- (5) The outside of a rear mudguard, except a mudflap, of a vehicle that can be seen from the rear of the vehicle must be coloured white or silver if the vehicle:
 - (a) is at least 2.2 metres wide, and
 - (b) has a body the vertical measurement of which is under 300 millimetres at the rear, measured from the lowest point of the body above ground level to the highest point, and
 - (c) is not fitted with rear marking plates in accordance with rule 115.

33 Horns, alarms etc. (cf ALVSR 2015 r 33; 2007 reg Sch 2 cl 33)

- (1) In this rule:

repeater horn means a device that makes a sound alternating between different tones or frequencies on a regular time cycle.
- (2) A motor vehicle must be fitted with at least 1 horn or other device that can give sufficient audible warning to other road users of the approach or position of the vehicle.
- (3) A motor vehicle must not be fitted with a device that can make a sound like the sound of a siren, exhaust whistle, compression whistle or repeater horn.
- (4) However, subrule (2) does not apply to:
 - (a) an exempt vehicle, or
 - (aa) a vehicle at least 25 years old and fitted as an emergency vehicle or police vehicle if the vehicle:
 - (i) is used only for exhibition purposes, or

- (ii) is part of a collection of former emergency vehicles or police vehicles,
or
 - (b) an anti-theft alarm if the alarm cannot be operated while the vehicle's ignition is on, or
 - (c) a vehicle used by a Traffic Commander or a Traffic Emergency Patroller appointed or employed by the Authority.
- (5) Also, a motor vehicle may be fitted with a device that emits a regular, intermittent sound while the vehicle is reversing or in reverse gear.
- (6) The device must not be louder than is necessary so the driver, and a person near the vehicle, can hear the device when it is operating.

34 Rear vision mirrors (cf ALVSR 2015 r 34; 2007 reg Sch 2 cl 34)

- (1) A rear vision mirror or mirrors must be fitted to a motor vehicle as required by this rule so that a driver of the vehicle can clearly see by reflection the road behind the vehicle and any following or overtaking vehicle.
- (2) At least 1 rear vision mirror must be fitted to:
- (a) a car, and
 - (b) a motor trike with 2 front wheels, and
 - (c) a motor bike, or motor trike with 1 front wheel, built before July 1975.
- (3) At least 1 rear vision mirror must be fitted to each side of the motor vehicle:
- (a) if the vehicle has a GVM over 3.5 tonnes, or
 - (b) if the vehicle is a motor bike, or motor trike with 1 front wheel, built after June 1975, or
 - (c) if the vehicle is constructed for the carriage of goods (not being a station wagon), or
 - (d) if the vehicle is a bus, or
 - (e) if the maximum width of any trailer or other vehicle drawn by the vehicle is greater than that of the vehicle, or
 - (f) if because of the manner in which the vehicle is constructed, equipped or loaded, or because of the fact that the vehicle is drawing a trailer or other vehicle, or for any other reason, the driver cannot, by means of a mirror fixed to the interior of the vehicle, have reflected to him or her as far as practicable a clear view of the road to the rear of the vehicle and of any following or overtaking vehicle.
- (4) A motor vehicle with a GVM not over 3.5 tonnes (except a motor vehicle mentioned in subrule (2) or (3)) must be fitted with:
- (a) at least 1 rear vision mirror on the right side of the vehicle, and
 - (b) at least 1 rear vision mirror on the left side of the vehicle or inside the vehicle.
- (5) A rear vision mirror fitted to a motor vehicle with a GVM over 3.5 tonnes must not project over 150 millimetres beyond the widest part (excluding lights, signalling devices and reflectors) of the vehicle or combination.
- (6) However, the rear vision mirror may project not over 230 millimetres beyond the widest part of the vehicle or combination if it can fold to project not over 150 millimetres beyond the overall width of the vehicle, measured in accordance with the prescribed dimension requirements applying to the vehicle.

35 Rear vision mirrors—surfaces (cf ALVSR 2015 r 35; 2007 reg Sch 2 cl 35)

- (1) A rear vision mirror required to be fitted to the side of a motor vehicle with a GVM over 3.5 tonnes must have a reflecting surface of at least 150 square centimetres.
- (2) The reflecting surface of the rear vision mirrors that are required to be fitted to a motor bike or moped must:
 - (a) each be of the same curvature, and
 - (b) if convex, be part of a notional sphere with a radius of at least 1.2 metres.

36 Additional rear vision mirrors (cf ALVSR 2015 r 36; 2007 reg Sch 2 cl 36)

A motor vehicle may be fitted with additional rear vision mirrors or mirror surfaces that are flat or convex or a combination of flat and convex surfaces.

37 Automatic transmission (cf ALVSR 2015 r 37; 2007 reg Sch 2 cl 37)

- (1) A motor vehicle fitted with an automatic transmission must have an engine starter mechanism that cannot operate when the transmission control is in a position to drive the vehicle.
- (2) A vehicle built after 1975 that is fitted with an automatic transmission must have an indicator in the driver's compartment showing the transmission control position.
- (3) Subrules (1) and (2) do not apply to a motor vehicle with less than 4 wheels.
- (4) If a motor vehicle (other than a motor bike or an implement) manufactured on or after 9 January 1976 is equipped with automatic transmission:
 - (a) the transmission control lever position and an indication of the transmission gear ratio selected must be displayed within the driver's compartment in such a location that they will be readily visible to the driver, and
 - (b) the sequence of transmission control lever positions must:
 - (i) include a neutral position (whereby no power is transmitted to the driving wheels) located between the reverse drive and forward drive positions, and
 - (ii) in cases where a park position (whereby forward or rearward movement of the vehicle is prevented) is included, be such that the park position is located at the end of the sequence adjacent to the reverse drive position.
- (5) If a car or a motor car derivative manufactured on or after 9 January 1976 is equipped with automatic transmission:
 - (a) if the transmission control lever is located on the steering column:
 - (i) the movement of the lever from neutral to reverse must be clockwise except that in cases where all lever positions are to the right of the vertical longitudinal plane through the centre of the steering wheel, the movement of the lever from neutral to reverse must be anti-clockwise, and
 - (ii) the movement of the device provided to indicate the transmission gear ratio selected must be generally in the same linear or rotational direction as the movement of the lever, and
 - (b) if the transmission control lever is located in a position other than on the steering column:
 - (i) all lever positions must be to the left of the vertical longitudinal plane through the centre of the steering wheel, and
 - (ii) movement of the lever from neutral to reverse must be generally upwards, forward or to the left according to whether the lever is

constrained to be moved generally in a vertical, longitudinal or transverse direction, as the case may be.

38 Diesel engines (cf ALVSR 2015 r 38; 2007 reg Sch 2 cl 38)

A motor vehicle propelled by a compression ignition engine (commonly known as a diesel engine) must be fitted with a device preventing the engine from being started accidentally or inadvertently.

39 Bonnet securing devices (cf ALVSR 2015 r 39; 2007 reg Sch 2 cl 39)

- (1) A motor vehicle with a moveable body panel forward of the windscreen that covers an engine or luggage storage or battery compartment must have a device to secure the panel.
- (2) However, if the panel opens from the front in a way that partly or completely obstructs the driver's forward view through the windscreen, the panel must have primary and secondary devices to secure the panel.

40 Electrical wiring, components, connections and installations (cf ALVSR 2015 r 40; 2007 reg Sch 2 cl 40)

- (1) The wiring of electrical equipment of a vehicle, except the high tension ignition wiring, must:
 - (a) be supported at intervals of not over 600 millimetres, unless the vehicle is a pole-type trailer with a pole with an adjustable length, or an extendible trailer, and
 - (b) be insulated at each of its joints, and
 - (c) be located where it cannot:
 - (i) become overheated, or
 - (ii) contact moving parts, or
 - (iii) come near enough to the fuel system to be a fire hazard, and
 - (d) be protected from chafing.
- (2) The electrical components of a vehicle must be securely mounted.
- (3) The electrical connectors between motor vehicles and trailers, for operation of the vehicle lights required by these rules, must comply with Australian Standard AS 4177.5-2004 *Caravan and light trailer towing components—Electrical connectors*.
- (4) A trailer must be equipped with an electrical conductor, independent of the trailer coupling, that provides a return path between the electrical circuits of the trailer and towing vehicle.

40A NSW rule: speedometers (cf 2007 reg Sch 2 cl 41)

Every motor vehicle (not being a trailer) manufactured on or after 1 July 1974 and capable of being driven at a speed in excess of 40 kilometres per hour on a level road must be fitted with a speedometer that must:

- (a) indicate the speed at which the vehicle is being driven in kilometres per hour, and
- (b) indicate, when the vehicle is travelling at a speed in excess of 50 kilometres per hour, a speed that is not more than 10% less than the actual speed, and
- (c) be readily visible to the driver.

41 Television receivers and visual display units (cf ALVSR 2015 r 41; 2007 reg Sch 2 cl 42)

- (1) A television receiver or visual display unit must not be installed in a vehicle so any part of the image on the screen is visible to the driver from the normal driving position.
- (2) However, subrule (1) does not apply to:
 - (a) a television receiver or visual display unit that cannot be operated when the vehicle is moving, or
 - (b) a driver's aid in any vehicle or a destination sign in a bus.

Examples of driver's aids:

1. Closed-circuit television security cameras.
 2. Dispatch systems.
 3. Navigational or intelligent highway and vehicle system equipment.
 4. Rearview screens.
 5. Ticket-issuing machines.
 6. Vehicle monitoring devices.
- (3) A television receiver, or visual display unit, and its associated equipment in a vehicle must be securely mounted in a position that:
 - (a) does not obscure the driver's view of the road, and
 - (b) does not impede the movement of a person in the vehicle.

42 Requirement for windscreen to be fitted (cf ALVSR 2015 r 42)

A motor vehicle (but not including a motor bike, a motor trike or a moped) must be fitted with a windscreen if it is manufactured or designed to have a windscreen.

42A NSW rule: windows generally (cf 2007 reg Sch 2 cl 43)

- (1) Every window must be sound and properly fitted and each movable window must be fitted with a suitable device to enable it to be opened and closed.
- (2) At least half of the number of windows must be capable of being opened.

43 Windscreens and windows (cf ALVSR 2015 r 43; 2007 reg Sch 2 cl 44)

- (1) In this rule:

approved material means material with the same characteristics as material mentioned in any of the following:

 - (a) Australian and New Zealand Standard AS/NZS 2080:2006 *Safety glazing for land vehicles*,
 - (b) Australian and New Zealand Standard AS/NZS 2080:1995 *Safety glass for land vehicles*,
 - (c) Australian Standard AS 2080–1983 *Safety glass for land vehicles* up to and including amendment No 1,
 - (d) New Zealand Standard NZS 5443:1987 *Safety glass for land vehicles*,
 - (e) Japanese Industrial Standard JIS R 3211:2015 *Safety glazing materials for road vehicles*,
 - (f) Japanese Industrial Standard JIS R 3211:1998 *Safety glazing materials for road vehicles*,
 - (g) Japanese Industrial Standard JIS R 3211–1992 *Safety glass for road vehicles*,

- (h) United Nations Economic Commission for Europe Regulation No 43 *Uniform provisions concerning the approval of safety glazing materials and their installation on vehicles* second revision as in force 12 August 2004,
- (i) United Nations Economic Commission for Europe Regulation No 43 *Uniform provisions concerning the approval of safety glazing materials and their installation on vehicles* Revision 1 of 25 February 1988,
- (j) British Standard BS AU178:1980 *Specification for road vehicle safety glass*,
- (k) British Standard BS AU178a:1992 *Specification for road vehicle safety glass*,
- (l) American National Standard ANSI/SAE Z26.1–1996 *American National Standard for Safety Glazing Materials for Glazing Motor Vehicles and Motor Vehicle Equipment Operating on Land Highways - Safety Code*,
- (m) American National Standard ANSI/SAE Z26.1–1980 *American National Standard for Safety Glazing Materials for Glazing Motor Vehicles and Motor Vehicle Equipment Operating on Land Highways - Safety Code*.

transparent material does not include any coating added to the windscreen, window or partition after its manufacture.

- (2) Transparent material used in a windscreen, window or an interior partition, of a motor vehicle must be of approved material if:
 - (a) the vehicle was built after June 1953, or
 - (b) the material was first fitted to the vehicle after June 1953.
- (3) Despite subrule (2), non-shatterable transparent material may be used in a window or an interior partition of a motor vehicle.

44 Window tinting (cf ALVSR 2015 r 44; 2007 reg Sch 2 cl 45)

- (1) In this rule:
 - glazing:**
 - (a) means material that may be used in a windscreen, window or interior partition of a motor vehicle, through which the vehicle's driver can see the road, but
 - (b) does not include a coating added after manufacture of the material.
 - luminous transmittance**, for glazing or a coating on glazing, means the amount of light that can pass through the glazing as a percentage of the amount of light that would be transmitted if the glazing or coating were absent.
 - rear glazing**, for a motor vehicle, means glazing used in a window or interior partition of the motor vehicle located behind the driver in the normal driving position.
- (2) Glazing used in a windscreen of a motor vehicle must have a luminous transmittance of at least 70%.
- (3) Glazing used in a windscreen of a motor vehicle must not be coated in a way that reduces its luminous transmittance.
- (4) However, subrules (2) and (3) do not apply to the greater of the following areas of a windscreen:
 - (a) the area above the highest point of the windscreen that is swept by a windscreen wiper,
 - (b) the upper 10% of the windscreen.
- (5) Glazing used in a window or interior partition of a motor vehicle must have a luminous transmittance of at least 70%.

- (6) Glazing used in a window or interior partition of a motor vehicle, other than rear glazing, may be coated to achieve a luminous transmittance of not less than 35%.
- (6A) If a motor vehicle is fitted with at least 1 rear vision mirror to each side of the vehicle, the motor vehicle's rear glazing may be coated to achieve a luminous transmittance of at least 20%.
- (6B) If all of the following apply to a motor vehicle, the motor vehicle's rear glazing may be coated to achieve a luminous transmittance of 0% or more:
 - (a) the vehicle is fitted with at least 1 rear vision mirror to each side of the vehicle,
 - (b) the vehicle is designed primarily for the carriage of goods,
 - (c) the vehicle has:
 - (i) at least 4 wheels, or
 - (ii) at least 3 wheels and a GVM of more than 1 tonne.
- (7) The requirements about luminous transmittance applying to glazing used in a window of a motor vehicle stated in a second edition ADR or third edition ADR do not apply to a window that has been coated as provided in subrules (6), (6A) or (6B).
- (8) Glazing used in a windscreen, window or interior partition of a motor vehicle that has been coated to reduce its luminous transmittance must not have a reflectance of more than 10%.

44A NSW rule: glazing in windscreens, windows and interior partitions (cf 2007 reg Sch 2 cl 46)

- (1) Rule 44 does not apply in relation to:
 - (a) any part of the glazing of a window (other than a windscreen) or interior partition of a motor vehicle that was first registered (whether or not in New South Wales) before 1 August 1994, if that part of the glazing has a luminous transmittance of not less than:
 - (i) 35% (except when subparagraph (ii) applies), or
 - (ii) the luminous transmittance it had immediately before 1 August 1994 if it had a luminous transmittance of less than 35% at that time, or
 - (b) any part of the glazing of a window (other than a windscreen) or interior partition of a motor vehicle that was first registered (whether or not in New South Wales) on or after 1 August 1994, if:
 - (i) that part of the glazing has a luminous transmittance of not less than 35%, and
 - (ii) the motor vehicle is equipped with an external rear vision mirror, or external rear vision mirrors, complying with the requirements of rule 34, or
 - (c) any part of the glazing of a window or interior partition in a caravan, or
 - (d) any part of the glazing of a windscreen, window or interior partition in a motor vehicle that was first registered before 1 July 1984, being glazing that was fitted to the motor vehicle on or before the date on which it was so registered.
- (2) For the purposes of rule 44 and this rule, the luminous transmittance or reflectance of glazing must be determined in accordance with the luminous transmittance test or the reflectance test, as the case may require, set out in any technical specification published by or adopted by the Authority from time to time.

45 Windscreen wipers and washers (cf ALVSR 2015 r 45; 2007 reg Sch 2 cl 47)

- (1) A motor vehicle with 3 or more wheels that is fitted with a windscreen must be fitted with at least 1 windscreen wiper unless a driver in a normal driving position can

obtain an adequate view of the road ahead of the motor vehicle without looking through the windscreen.

- (2) At least 1 windscreen wiper fitted to the motor vehicle must:
 - (a) be able to remove moisture from the part of the windscreen in front of the driver to allow the driver an adequate view of the road ahead of the motor vehicle when the windscreen is wet, and
 - (b) be able to be operated from a normal driving position, and
 - (c) for a motor vehicle built after 1934—continue to operate until the wiper is switched off, and
 - (d) for a motor vehicle built after 1959 the driving position of which is nearer one side of the vehicle than the other:
 - (i) be able to remove moisture from the part of the windscreen in front of the driver, and a corresponding part of the windscreen on the other side of the centre of the motor vehicle, to allow the driver an adequate view of the road ahead of the motor vehicle when the windscreen is wet, and
 - (ii) if the windscreen wipers are operated by engine manifold vacuum—be provided with a vacuum reservoir or pump to maintain the efficient operation of the wiper or wipers while the vehicle is in motion.
- (3) The windscreen washer must be able to be operated from a normal driving position.

46 Wheels and tyres—size and capacity (cf ALVSR 2015 r 46; 2007 reg Sch 2 cl 48)

The wheels and tyres fitted to an axle of a vehicle must be of sufficient size and capacity to carry the part of the vehicle's gross mass transmitted to the ground through the axle.

47 Pneumatic tyres generally (cf ALVSR 2015 r 47; 2007 reg Sch 2 cl 49)

A vehicle built after 1932 must be fitted with pneumatic tyres.

48 Pneumatic tyres—carcass construction (cf ALVSR 2015 r 48; 2007 reg Sch 2 cl 50)

- (1) A vehicle must not have pneumatic tyres of different carcass construction fitted to the same axle, but the tyres may have different cord materials and a different number of plies.
- (2) However, subrule (1) does not apply to a tyre being used in an emergency as a temporary replacement for a tyre complying with the subrule.

48A NSW rule: pneumatic tyres—size and capacity (cf 2007 reg Sch 2 cl 51)

The size and capacity of a pneumatic tyre to be fitted to a vehicle must be decided using a cold inflation pressure that is not more than the lesser of:

- (a) the pressure recommended by the tyre manufacturer, and
- (b) a pressure of:
 - (i) for a radial ply tyre—825 kilopascals, or
 - (ii) for another tyre—700 kilopascals.

49 Tyres—defects (cf ALVSR 2015 r 49; 2007 reg Sch 2 cl 52)

A tyre fitted to a vehicle must be free of any apparent defect that could make the vehicle unsafe.

50 Tyres—manufacturer's rating (cf ALVSR 2015 r 50; 2007 reg Sch 2 cl 54)

- (1) This rule applies to a motor vehicle if the vehicle:

- (a) has 4 or more wheels, and
 - (b) was built after 1972.
- (2) However, this rule does not apply to a tyre if the tyre:
- (a) is recommended by the vehicle builder as suitable for limited use on the vehicle in special circumstances at a speed less than the speed applying to the vehicle under subrule (3), or
 - (b) is being used in an emergency as a temporary replacement for a tyre complying with this rule.
- (3) A tyre fitted to a motor vehicle must, when first manufactured, have been rated by the tyre manufacturer as suitable for road use at the lesser of:
- (a) a speed of at least:
 - (i) for a car with special features for off-road use—140 kilometres an hour, or
 - (ii) for another car—180 kilometres an hour, or
 - (iii) for another motor vehicle—120 kilometres an hour, and
 - (b) the vehicle's top speed.
- (4) Despite rule 25B, this rule applies to a vehicle instead of the tyre speed category requirements in the relevant ADR.

51 Retreads (cf ALVSR 2015 r 51; 2007 reg Sch 2 cl 55)

- (1) A tyre that is retreaded before 29 June 1998 must not be used on a vehicle if:
- (a) Australian Standard AS 1973–1976 *Retreaded pneumatic passenger car and light truck tyres* or Australian Standard AS 1973–1985 *Retreaded pneumatic passenger car and light truck tyres* applies to the tyre, and
 - (b) the tyre was retreaded after publication of the Australian Standard, and
 - (c) the tyre was not retreaded in accordance with Australian Standard AS 1973–1976 *Retreaded pneumatic passenger car and light truck tyres*, Australian Standard AS 1973–1985 *Retreaded pneumatic passenger and light truck tyres* or Australian Standard AS 1973–1993 *Pneumatic tyres—Passenger car, light truck and truck/bus—Retreading and repair processes*.
- (2) A tyre that is retreaded after 29 June 1998 must not be used on a vehicle if:
- (a) Australian Standard AS 1973–1993 *Pneumatic tyres—Passenger car, light truck and truck/bus—Retreading and repair processes* applies to the tyre, and
 - (b) the tyre was not retreaded in accordance with that Australian Standard.

52 Tyre tread (cf ALVSR 2015 r 52; 2007 reg Sch 2 cl 56)

- (1) A tyre on a motor vehicle must not have cleats or other gripping devices that could damage road surfaces.
- (2) Except at tread wear indicators, a tyre fitted to the vehicle must have a tread pattern at least 1.5 millimetres deep in a band that runs continuously:
- (a) across the tyre width that normally comes into contact with the road, and
 - (b) around the whole circumference of the tyre.
- (3) A vehicle must not be fitted with a tyre that has been treated by recutting or regrooving the tread rubber, unless the tyre was:

- (a) constructed with an extra thickness of rubber designed for recutting or regrooving, and
- (b) labelled to indicate the construction.

Division 2 Additional requirements for motor bikes

53 Steering gear and handlebars (cf ALVSR 2015 r 53; 2007 reg Sch 2 cl 57)

- (1) The handlebars on a motor bike must extend at least 250 millimetres, but not over 450 millimetres, on each side of the centre line of the vehicle.
- (2) In taking a measurement for subrule (1), mirrors and lights mounted on the handlebars of the motor bike are disregarded.
- (3) The lowest part of the hand grip on the handle bars must not be higher than 380 millimetres above the attachment point of the handlebars to the motor bike.
- (4) Hand grips on the handle bars must be fitted symmetrically.
- (5) If a motor bike has the head stem as the steering pivot point, the horizontal distance from the midpoint between the head stem bearings to the centre of the front wheel must not be over 550 millimetres.

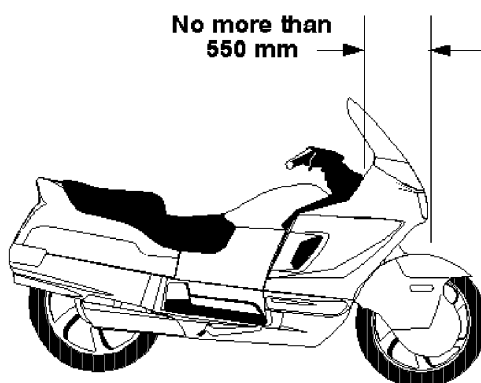

Maximum horizontal distance from midpoint between head stem bearings of motor bike to centre of front wheel

54 Foot rests (cf ALVSR 2015 r 54; 2007 reg Sch 2 cl 58)

A motor bike must be fitted with foot rests for the driver, and for any passenger for whom a seating position is provided.

55 Chain guards (cf ALVSR 2015 r 55; 2007 reg Sch 2 cl 59)

- (1) If the engine power of a motor bike is transmitted to the rear wheel by a chain, the driver and any passenger must be protected from the front sprocket and at least the upper part of the chain by:
 - (a) the frame or equipment of the motor bike, or
 - (b) a chain guard.
- (2) A chain guard must cover the chain to a point:
 - (a) at least 300 millimetres to the rear of the rearmost foot rest, or
 - (b) above the centre of the rear drive sprocket.

Part 5 Vehicle marking

Note. This Part contains requirements for a vehicle that help to identify the vehicle and, if the vehicle is unusually long, to warn other motorists.

56 Vehicle and engine identification numbers (cf ALVSR 2015 r 56; 2007 reg Sch 2 cl 60)

- (1) A motor vehicle must have an individual engine identification number clearly stamped, embossed or otherwise permanently marked on it.
- (2) A motor vehicle built after 1930 must have the engine identification number on its engine block or the main component of its engine.
- (3) A vehicle must have an individual vehicle identification number clearly stamped, embossed or otherwise permanently marked on a substantial part of its frame or chassis.
- (4) A vehicle or engine identification number must be located where a person can read it easily without having to use tools to remove a part of the vehicle that would otherwise obstruct the person's view.

56A NSW rule: compliance plates to be affixed to certain vehicles (cf 2007 reg Sch 2 cl 62)

- (1) Any motor vehicle (other than a tractor or an implement) registered for the first time on or after 1 August 1972 must have securely and prominently affixed within the engine compartment or other position approved by the Authority a plate approved by the Australian Motor Vehicle Certification Board or the Administrator of Vehicle Standards that:
 - (a) identifies the specific vehicle, and
 - (b) indicates that it meets the standards and procedures administered by the Australian Motor Vehicle Certification Board for that class of vehicle.

- (2) In this rule:

Administrator of Vehicle Standards means the Administrator of Vehicle Standards referred to in section 22 of the *Motor Vehicle Standards Act 1989* of the Commonwealth.

Australian Motor Vehicle Certification Board means the body:

- (a) known under that name, and
- (b) consisting of representatives of the Commonwealth and each of the States and Territories, and
- (c) having as one of its objectives to ensure that vehicles supplied for use in, manufactured in, or imported into, Australia are designed and manufactured so as to:
 - (i) comply with the requirements of Australian Design Rules, or
 - (ii) provide a level of safety that is equivalent to that provided by Australian Design Rules.

57 White or silver band on certain vehicles (cf ALVSR 2015 r 57; 2007 reg Sch 2 cl 64)

- (1) This rule applies to a vehicle that:
 - (a) is at least 2.2 metres wide, and
 - (b) has a body with a vertical measurement under 300 millimetres at the rear, measured from the lowest point of the body above ground level to the highest point, and
 - (c) is not fitted with rear marking plates in accordance with rule 115.

- (2) The vehicle must have a white or silver band at least 75 millimetres high across the full width of the rearmost part of the body of the vehicle.

Part 6 Vehicle configuration and dimensions

Note. This Part sets out various requirements covering the suspension on vehicles and size limits for single vehicles and combinations of vehicles so that they can be operated safely with other traffic, without taking up too much road space or damaging the road and structures on the road.

Generally, the limits in this Part apply to a vehicle and any load it may be carrying.

Specific requirements for loaded vehicles are covered by other laws.

Division 1 Axles

58 Axle configuration (cf ALVSR 2015 r 58; 2007 reg Sch 2 cl 69)

- (1) A motor vehicle must have only:
 - (a) 1 axle group, or single axle, towards the front of the vehicle, and
 - (b) 1 axle group, or single axle, towards the rear of the vehicle.
- (2) A trailer must have only:
 - (a) 1 axle group or single axle, or
 - (b) 2 axle groups, 2 single axles, or 1 axle group and single axle, in the following configuration:
 - (i) 1 axle group, or single axle, towards the front of the vehicle, with all the wheels on the axle group or single axle connected to the steering mechanism for that part of the trailer,
 - (ii) 1 axle group, or single axle, towards the rear of the vehicle.
- (3) A semi-trailer that is extendible, or is fitted with sliding axles, must:
 - (a) have a securing device that:
 - (i) can securely fix the extendible part or sliding axles to the rest of the vehicle in any position of adjustment provided, and
 - (ii) is located in a position that can prevent accidental or inadvertent release, if the device is mounted on the chassis of the vehicle, and
 - (iii) is fitted with a visible or audible warning system to indicate to a person standing beside the vehicle that the device is not engaged, and
 - (iv) is fitted with a way of preventing loss of air from the air brake supply, if the device uses air from the brake system and fails in a way allowing air to escape, and
 - (v) is held in the applied position by direct mechanical action without the intervention of an electric, hydraulic or pneumatic device, and
 - (b) be built so the adjustable parts of the vehicle remain connected if the securing device fails.

59 Retractable axles (cf ALVSR 2015 r 59; 2007 reg Sch 2 cl 181)

- (1) In this rule:

retractable axle means an axle with a means of adjustment enabling it to be raised or lowered relative to the other axles in the axle group.
- (2) For these rules, a retractable axle is taken to be an axle only when it is in the lowered position.

Division 2 Dimension requirements

60 Australian Light Vehicle Standards Rule not reproduced (cf ALVSR 2015 r 60; 2007 reg Dictionary definitions of "rear overhang" and "rear overhang line")

* * * * *

Note. Rule 60 (Meaning of *rear overhang* and *rear overhang line*) of the *Australian Light Vehicle Standards Rules 2015* has not been reproduced in these rules because the relevant terms are defined in the Dictionary to this Regulation.

61 Length of single motor vehicles (cf ALVSR 2015 r 61; 2007 reg Sch 2 cl 72)

A motor vehicle must not be over 12.5 metres long.

62 Length of single trailers (cf ALVSR 2015 r 62; 2007 reg Sch 2 cl 73)

- (1) On a semi-trailer or a dog trailer:
 - (a) the distance between the point of articulation at the front of the trailer and the rear overhang line must not be over 9.5 metres, and
 - (b) the distance between the point of articulation at the front of the trailer and the rear of the trailer must not be over 12.3 metres.
- (2) A projection forward of the point of articulation at the front of a semi-trailer must be contained within a radius of 1.9 metres from the point of articulation.

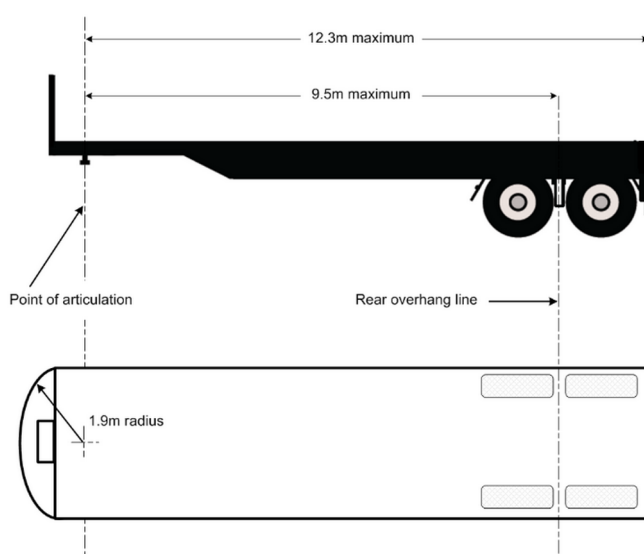

Maximum dimensions of a semi-trailer

63 Length of combinations (cf ALVSR 2015 r 63; 2007 reg Sch 2 cl 74)

A combination must not be over 19 metres long.

64 Rear overhang (cf ALVSR 2015 r 64; 2007 reg Sch 2 cl 75)

- (1) The rear overhang of a semi-trailer, or dog trailer consisting of a semi-trailer and converter dolly, must not exceed the lesser of:
 - (a) 60% of the distance between the point of articulation at the front and the rear overhang line, and
 - (b) 3.7 metres.

- (2) The rear overhang of a trailer with only 1 axle group or single axle (except a semi-trailer) must not exceed the lesser of:
 - (a) the length of the load carrying area, or body, ahead of the rear overhang line, and
 - (b) 3.7 metres.
- (3) The rear overhang of a vehicle not mentioned in subrule (1) or (2) must not exceed the lesser of:
 - (a) 60% of the distance between the centre of the front axle and the rear overhang line, and
 - (b) 3.7 metres.

65 Length—trailer drawbars (cf ALVSR 2015 r 65; 2007 reg Sch 2 cl 76)

- (1) The distance between the coupling pivot point on the drawbar of a dog trailer, and the centre line of the front axle group or of the front single axle of the trailer, must not be over 5 metres.

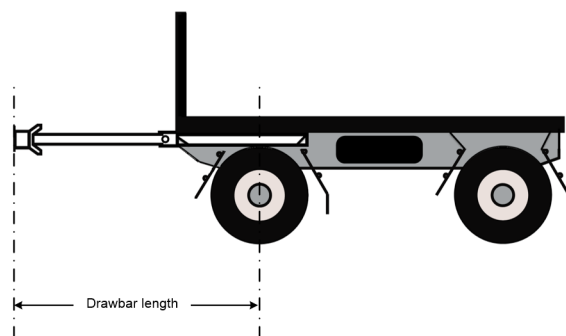

Length of a drawbar on a dog trailer

- (2) The distance between the coupling pivot point on a drawbar, and the centre line of the axle group or single axle on a trailer with only 1 axle group or single axle (except a semi-trailer) must not be over 8.5 metres.

66 Width (cf ALVSR 2015 r 66; 2007 reg Sch 2 cl 71)

A vehicle must not be over 2.5 metres wide.

67 Height (cf ALVSR 2015 r 67; 2007 reg Sch 2 cl 77)

A vehicle must not be over 4.3 metres high.

68 Ground clearance (cf ALVSR 2015 r 68; 2007 reg Sch 2 cl 78)

- (1) In this rule:

ground clearance, of a vehicle, means the minimum distance to the ground from a point on the underside of the vehicle, except a point on a tyre, wheel, wheel hub, brake backing plate or flexible mudguard or mudflap of the vehicle.
- (2) A motor vehicle or combination must have a ground clearance of:
 - (a) at least 100 millimetres at any point within 1 metre of an axle, and
 - (b) at least one-thirtieth of the distance between the centres of adjacent axles at the midpoint between them, and

- (c) at any other point—at least the distance that allows the vehicle or combination to pass over a peak in the road with a gradient on either side of 1:15, if the wheels of 1 axle of the vehicle or combination are on the slope on one side of the peak and the wheels of the next axle are on the slope on the other side.
- (3) However, subrule (2) does not apply to:
- (a) a motor vehicle with less than 4 wheels, or
 - (b) a combination that includes a motor vehicle with less than 4 wheels.

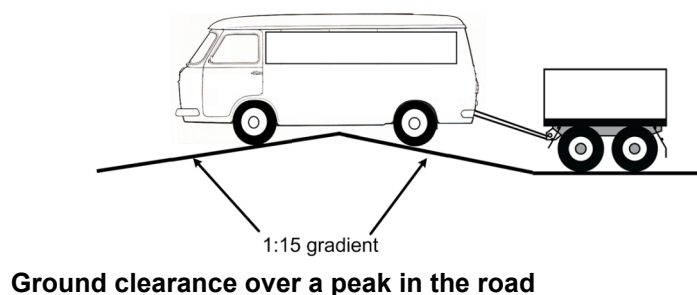
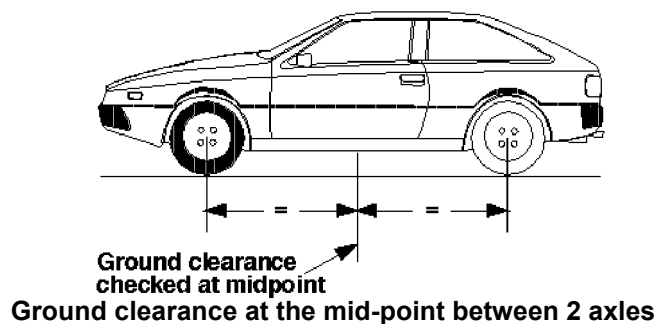

Part 7 Lights and reflectors

Note. This Part deals with how the lights on a vehicle must be fitted and work so that the driver can see the road, pedestrians and other vehicles at night, and can signal to others.

Other laws provide for when certain lights must be switched on.

In this Part, the description “yellow” is used as a more modern term, instead of the description “amber” which is used in earlier legislation and some ADRs.

Division 1 Application of particular requirements

69 Part does not apply to particular vehicles (cf ALVSR 2015 r 69; 2007 reg Sch 2 cl 131 and 132)

- (1) This Part does not apply to a vehicle built before 1931 that is used only in the daylight.
- (2) This Part does not apply to a vehicle built before 1946 that is used mainly for exhibition purposes.

70 Particular requirements apply only at night (cf ALVSR 2015 r 70; 2007 reg Sch 2 cl 83)

The requirements of this Part for a light, except a brake or direction indicator light, to be visible over a stated distance apply only at night.

Division 2 General requirements for lights

70A NSW rule: lighting devices that can be attached to vehicles (cf 2007 reg Sch 2 cl 82)

A device capable of projecting light must not be attached to any vehicle unless it is a device required or permitted to be attached to the vehicle by these rules.

71 Prevention of glare (cf ALVSR 2015 r 71; 2007 reg Sch 2 cl 84)

A light, except a high-beam headlight, fitted to a vehicle must be built and adjusted to provide the necessary amount of light without dazzling the driver of another vehicle approaching, or being approached by, the vehicle.

72 Pairs of lights (cf ALVSR 2015 r 72; 2007 reg Sch 2 cl 85)

- (1) If lights are required under these rules to be fitted to a vehicle in pairs:
 - (a) a light must be fitted on each side of the longitudinal axis of the vehicle, and
 - (b) the centre of each light in a pair must be the same distance from the longitudinal axis of the vehicle, and
 - (c) the centre of each light in a pair must be at the same height above ground level, and
 - (d) each light in a pair must project approximately the same amount of light of the same colour.
- (2) Subrule (1) applies to a motor bike with an attached sidecar as if the sidecar were not attached.

Division 3 Headlights

73 Headlights to be fitted to vehicles (cf ALVSR 2015 r 73; 2007 reg Sch 2 cl 86)

- (1) A motor vehicle must be fitted with:
 - (a) 1 low-beam headlight if it is a moped, motor bike, or motor trike with 1 front wheel, or
 - (b) a pair of low-beam headlights if it has 4 or more wheels or is a motor trike, except a moped, with 2 front wheels.
- (2) If a motor vehicle built after 1934 can travel at over 60 kilometres an hour:
 - (a) each low-beam headlight mentioned in subrule (1) must be able to work in the high-beam position, or
 - (b) the vehicle must be fitted with:
 - (i) 1 headlight that can work in the high-beam position if the vehicle is required to have 1 low-beam headlight, or
 - (ii) a pair of headlights that can work in the high-beam position.
- (3) A motor bike may be equipped with a headlight modulation system that:
 - (a) varies the brightness of its high-beam headlight or low-beam headlight, but not both, at a rate of at least 200 and at most 280 flashes a minute, and
 - (b) is designed to operate only in daylight.
- (4) Additional headlights may be fitted to a motor bike or motor trike, or a motor vehicle with 4 or more wheels that was built before 1970.
- (5) Additional pairs of headlights may be fitted to a motor vehicle with 4 or more wheels that was built after 1969.

- (6) Despite rule 25B and any requirement of the third edition ADR, an emergency services vehicle may be fitted with headlights or additional headlights that are capable of flashing if:
 - (a) the headlights flash only when on low beam, and
 - (b) the headlights are wired to operate in conjunction with any flashing or rotating lights fitted to the vehicle as permitted by rule 114 (4).
- (7) In this rule, an **emergency services vehicle** means any of the following:
 - (a) a police vehicle,
 - (b) an ambulance,
 - (c) a firefighting vehicle,
 - (d) a Red Cross vehicle used for conveyance of blood for urgent transfusions,
 - (e) a mines rescue or other rescue vehicle,
 - (f) another vehicle that is an emergency vehicle within the meaning of the *Road Rules 2014*.

74 How headlights are to be fitted (cf ALVSR 2015 r 74; 2007 reg Sch 2 cl 87)

- (1) The centres of low-beam headlights fitted as a pair on a motor vehicle with 4 or more wheels must be at least 600 millimetres apart.
- (2) However, subrule (1) does not apply to a motor vehicle built before 1970 if the centres of its low-beam headlights:
 - (a) were under 600 millimetres apart when the vehicle was built, and
 - (b) are not nearer than they were when the vehicle was built.
- (3) Each low-beam headlight of a pair on a motor trike (except a moped) with 2 front wheels must not be over 400 millimetres from the nearer side of the vehicle.
- (4) The centre of a low-beam headlight fitted to a motor vehicle built after June 1953 must be:
 - (a) at least 500 millimetres above ground level, and
 - (b) not over 1.4 metres above ground level.

75 How single headlights are to be fitted (cf ALVSR 2015 r 75; 2007 reg Sch 2 cl 88)

- (1) A motor bike or trike with a single headlight fitted must have the light fitted in the centre.
- (2) Subrule (1) applies to a motor bike with an attached sidecar as if the sidecar were not attached.

76 NSW rule: how additional headlights are to be fitted (cf 2007 reg Sch 2 cl 89)

If 2 or more additional headlights are fitted to a motor vehicle with 4 or more wheels, the additional headlights must as far as possible be fitted in pairs.

77 Performance of headlights (cf ALVSR 2015 r 77; 2007 reg Sch 2 cl 90)

- (1) When on, a headlight, or additional headlight, fitted to a vehicle must:
 - (a) show only white light, and
 - (b) project its main beam of light ahead of the vehicle.
- (2) Headlights must be fitted to a vehicle so their light does not reflect off the vehicle into the driver's eyes.

78 Effective range of headlights (cf ALVSR 2015 r 78; 2007 reg Sch 2 cl 91)

- (1) This rule applies to a headlight that is on at night.
- (2) A low-beam headlight must illuminate the road ahead of the vehicle for at least 25 metres.
- (3) A high-beam headlight must illuminate the road ahead of the vehicle for at least 50 metres.
- (4) However, a low-beam headlight fitted to a motor vehicle built before 1931, or a moped, need only illuminate the road ahead of the vehicle for 12 metres.

79 Changing headlights from high-beam to low-beam position (cf ALVSR 2015 r 79; 2007 reg Sch 2 cl 92)

- (1) A motor vehicle built after 1934 that can travel at over 60 kilometres an hour must be fitted with:
 - (a) a dipping device enabling the driver in the normal driving position:
 - (i) to change the headlights from the high-beam position to the low-beam position, or
 - (ii) simultaneously to switch off a high-beam headlight and switch on a low-beam headlight, and
 - (b) for a vehicle built after June 1953—a device to indicate to the driver that the headlights are in the high-beam position.
- (2) A headlight fitted to a vehicle not fitted with a dipping device mentioned in subrule (1) (a) must operate in the low-beam position.
- (3) When a headlight fitted to a vehicle is switched to the low-beam position, any other headlight on the vehicle must operate only in the low-beam position or be off.
- (4) In this rule:

alternative headlight means a light which is lighted in the place of a headlight by a dipping device.

dipping device means a device by which the driver of a motor vehicle, while retaining his or her normal driving position:

- (a) can cause the main beam of light projected by each of the headlights of a motor vehicle which has 2 headlights or by the headlight of a motor vehicle which has one headlight to be dipped, or
- (b) can extinguish each of the headlights of a motor vehicle which has 2 headlights or the headlight of a motor vehicle which has one headlight, and simultaneously light 2 alternative headlights or one alternative headlight (as the case may be), or
- (c) can extinguish each set of headlights where a motor vehicle has 4 headlights, in sets of 2, and simultaneously light one light in each set.

Division 4 Parking lights

80 Parking lights (cf ALVSR 2015 r 80; 2007 reg Sch 2 cl 93)

- (1) A motor vehicle built after June 1953 must be fitted with:
 - (a) a pair of parking lights if it is a motor trike with 2 front wheels (except a moped) or a motor vehicle with 4 or more wheels, or
 - (b) at least 1 parking light if it is a motor bike with an attached sidecar, or a motor trike with 1 front wheel (except a moped).

- (2) A pair of parking lights fitted to a motor vehicle with 4 or more wheels must be fitted with the centre of each light:
 - (a) at least 600 millimetres from the centre of the other light, and
 - (b) not over 510 millimetres from the nearer side of the vehicle.
- (3) However, a pair of parking lights fitted to a motor vehicle under 1300 millimetres wide may be fitted with the centre of each light not under 400 millimetres from the centre of the other light.
- (4) A parking light fitted to a motor trike with 2 front wheels must not be over 400 millimetres from the nearer side of the vehicle.
- (5) A parking light fitted to a motor bike with a sidecar must be fitted not over 150 millimetres from the side of the sidecar furthest from the motor bike.

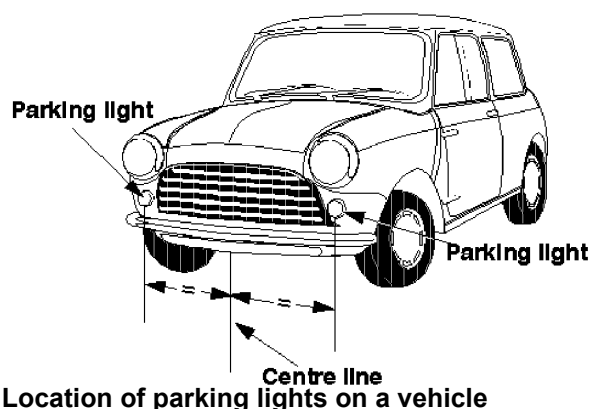

- (6) When on, a parking light must:
 - (a) show a white or yellow light visible 200 metres from the front of the vehicle, and
 - (b) not use over 7 watts power.
- (7) A parking light fitted to a motor vehicle built after 1969 must be wired so the parking light is on when a headlight on the vehicle is on.
- (8) A parking light fitted to a sidecar attached to a motor bike must be wired to operate when a headlight, tail light or parking light on the motor bike is on.

Division 5 Daytime running lights

81 Daytime running lights (cf ALVSR 2015 r 81; 2007 reg Sch 2 cl 94)

- (1) A pair of daytime running lights may be fitted to a motor vehicle.
- (2) A pair of daytime running lights fitted to a vehicle with 4 or more wheels must be fitted with the centre of each light:
 - (a) at least 600 millimetres from the centre of the other light, and
 - (b) not over 510 millimetres from the nearer side of the vehicle.
- (3) However, a pair of daytime running lights fitted to a motor vehicle under 1300 millimetres wide may be fitted with the centre of each light not under 400 millimetres from the centre of the other light.

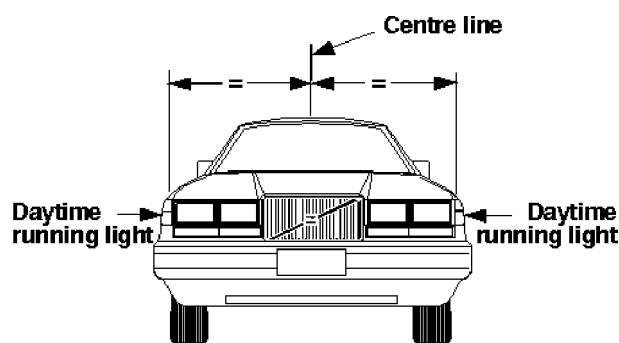

Location of daytime running lights on a vehicle

- (4) When on, a daytime running light must:
 - (a) show a white or yellow light visible from the front of the vehicle, and
 - (b) not use over 25 watts power.

Note. The third edition ADRs only allow white daytime running lights.
- (5) Daytime running lights must be wired so they are off when a headlight, except a headlight being used as a flashing signal, is on.

Division 6 Tail lights

82 Tail lights generally (cf ALVSR 2015 r 82; 2007 reg Sch 2 cl 95)

- (1) A vehicle must have at least 1 tail light fitted on or towards the rear of the vehicle.
- (2) A motor trike with 2 rear wheels, or a motor vehicle with 4 or more wheels, built after 1959 must have at least 1 tail light fitted on or towards each side of the rear of the vehicle.
- (3) A trailer built after June 1973 must have at least 1 tail light fitted on or towards each side of the rear of the vehicle.
- (4) The centre of a tail light mentioned in subrule (1), (2) or (3) must not be over:
 - (a) 1.5 metres above ground level, or
 - (b) if it is not practicable to fit the light lower—2.1 metres above ground level.
- (5) A vehicle may have 1 or more additional tail lights at any height above ground level.

83 Pattern of fitting tail lights (cf ALVSR 2015 r 83; 2007 reg Sch 2 cl 96)

- (1) If only 1 tail light is fitted to a vehicle, it must be fitted in the centre or to the right of the centre of the vehicle's rear.
- (2) Subrule (1) applies to a motor bike with an attached sidecar as if the sidecar were not attached.
- (3) If 2 or more tail lights are fitted to a vehicle, at least 2 must be fitted as a pair.

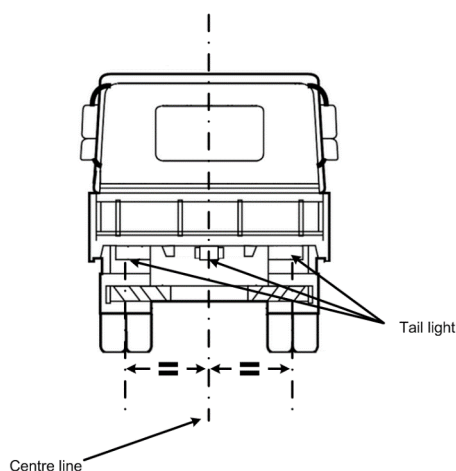

Location of tail lights on a vehicle

- (4) Tail lights fitted in accordance with this Division may also serve as rear clearance lights if they are fitted to a vehicle in accordance with rule 89 (3).

84 Performance of tail lights (cf ALVSR 2015 r 84; 2007 reg Sch 2 cl 97)

- (1) When on, a tail light of a vehicle must:
- (a) show a red light visible 200 metres from the rear of the vehicle, and
 - (b) not use over 7 watts power.
- (2) A tail light fitted to a street rod vehicle may incorporate a blue lens not over 20 millimetres in diameter.

85 Wiring of tail lights (cf ALVSR 2015 r 85; 2007 reg Sch 2 cl 98)

A tail light of a motor vehicle must be wired to come on, and stay on, when a parking light or headlight on the vehicle is on, unless an external switch is fitted to operate the tail light.

Division 7 Number-plate lights

86 Number-plate lights (cf ALVSR 2015 r 86; 2007 reg Sch 2 cl 99)

- (1) At least 1 number-plate light must be fitted to the rear of a vehicle.
- (2) When on, the number-plate light or lights must illuminate a number-plate on the rear of the vehicle with white light, so the characters on the number-plate can be read at night 20 metres from the rear of the vehicle.
- (3) A number-plate light:
- (a) may be combined with another light, and
 - (b) must not project white light to the rear of the vehicle except by reflection, and
 - (c) must not obscure the characters on the number-plate, and
 - (d) must be wired to come on, and stay on, when a parking light, headlight or tail light on the vehicle is on.
- (4) Subrules (2) and (3) apply to a number-plate light used to illuminate an auxiliary number-plate issued in respect of a vehicle as if the auxiliary number-plate were a number-plate on the rear of the vehicle.

Division 8 Clearance lights

87 Front clearance lights (cf ALVSR 2015 r 87; 2007 reg Sch 2 cl 100)

- (1) Front clearance lights may only be fitted to a vehicle that is at least 1.8 metres wide.
- (2) A pair of front clearance lights must be fitted to a motor vehicle that is at least 2.2 metres wide, or a prime mover.
- (3) The centre of a front clearance light must be:
 - (a) not over 400 millimetres from the nearer side of the vehicle, and
 - (b) if the vehicle was built after June 1953:
 - (i) at least 750 millimetres higher than the centre of any low-beam headlight fitted to the vehicle, or
 - (ii) not lower than the top of the windscreen.
- (4) However, a front clearance light may be mounted on an external rear vision mirror or a mirror support if, when the mirror is correctly adjusted, no part of the lens of the clearance light is visible to a person in the normal driving position.
- (5) When on, a front clearance light must:
 - (a) show a yellow or white light visible 200 metres from the front of the vehicle, and
 - (b) not use over 7 watts power.

88 External cabin lights (cf ALVSR 2015 r 88; 2007 reg Sch 2 cl 101)

- (1) A motor vehicle fitted with front clearance lights may also have additional forward-facing lights on or above the roof of its cabin.
- (2) The additional forward-facing lights must be spaced evenly between the front clearance lights, with their centres at least 120 millimetres apart.
- (3) When on, an additional forward-facing light must:
 - (a) show a yellow or white light, and
 - (b) not use over 7 watts power.

89 Rear clearance lights (cf ALVSR 2015 r 89; 2007 reg Sch 2 cl 102)

- (1) Rear clearance lights may only be fitted to a vehicle that is at least 1.8 metres wide.
- (2) A pair of rear clearance lights must be fitted to the rear of a vehicle that is at least 2.2 metres wide.
- (3) The centre of a rear clearance light must be:
 - (a) not over 400 millimetres from the nearer side of the vehicle, and
 - (b) if practicable, at least 600 millimetres above ground level.
- (4) When on, a rear clearance light must:
 - (a) show a red light visible 200 metres from the rear of the vehicle, and
 - (b) not use over 7 watts power.

Division 9 Side marker lights

90 Vehicles needing side marker lights (cf ALVSR 2015 r 90; 2007 reg Sch 2 cl 103)

- (1) A pair of side marker lights must be fitted towards the rear of the sides of a motor vehicle that is over 7.5 metres long and at least 2.2 metres wide.

- (2) A pole-type trailer, and a motor vehicle built to tow a pole-type trailer, with at least 1 cross-bar or bolster must have a side marker light fitted to each side of the back or only cross-bar or bolster.
- (3) A pole-type trailer with 2 or more cross-bars or bolsters may also have a side marker light fitted to each side of the front cross-bar or bolster.
- (4) At least 2 side marker lights must be fitted to each side of:
 - (a) a trailer, except a pole-type trailer, that is at least 2.2 metres wide and not over 7.5 metres long, and
 - (b) a semi-trailer that is not over 7.5 metres long.
- (5) At least 3 side marker lights must be fitted to each side of:
 - (a) a trailer, except a pole-type trailer, that is at least 2.2 metres wide and over 7.5 metres long, and
 - (b) a semi-trailer that is over 7.5 metres long.

91 Location of side marker lights (cf ALVSR 2015 r 91; 2007 reg Sch 2 cl 104)

- (1) The centre of a side marker light must not be over 150 millimetres from the nearer side of the vehicle.
- (2) A front side marker light fitted to a motor vehicle must be towards the front of the side of the vehicle with no part of the lens visible to the driver.
- (3) The centre of a front side marker light fitted to a trailer must be:
 - (a) within 300 millimetres of the front of the side of the trailer, or
 - (b) if the construction of the trailer makes it impracticable to comply with paragraph (a)—as near as practicable to the front of the trailer.
- (4) The centre of a rear side marker light fitted to a vehicle must be:
 - (a) within 300 millimetres of the rear of the side of the vehicle, or
 - (b) if the construction of the vehicle makes it impracticable to comply with paragraph (a)—as near as practicable to the rear of the vehicle.
- (5) Side marker lights fitted to a vehicle must, as far as practicable, be evenly spaced along the side of the vehicle.
- (6) Subrules (2)–(5) do not apply to side marker lights fitted to a cross-bar or bolster of a pole-type trailer.
- (7) Only the side marker lights nearest to the rear need be fitted if complying with subrules (3) and (4) would result in the front and rear side marker lights being under 2.5 metres apart.
- (8) A side marker light fitted to a vehicle must be fitted so that:
 - (a) its centre is not over:
 - (i) 1.5 metres above ground level, or
 - (ii) if it is not practicable to fit it lower—2.1 metres above ground level, and
 - (b) its centre is at least 600 millimetres above ground level, and
 - (c) it is, as far as practicable, in a row of side marker lights along the side of the vehicle.
- (9) Subrule (8) (a) does not apply to a side marker light that is not required to be fitted to the vehicle by rule 90.

92 Performance of side marker lights (cf ALVSR 2015 r 92; 2007 reg Sch 2 cl 105)

- (1) When on, a side marker light fitted to a vehicle must:
 - (a) show a light visible 200 metres from the vehicle, and
 - (b) not use over 7 watts power.
- (2) When on, a side marker light fitted to a vehicle must show:
 - (a) to the front of the vehicle—a yellow light, and
 - (b) to the rear of the vehicle:
 - (i) if the light also operates as a rear light or reflector—a red light, and
 - (ii) in any other case—a red or yellow light.
- (3) However, if a pole-type trailer with 2 or more cross-bars or bolsters has the side marker lights permitted by rule 90 (3):
 - (a) the side marker lights fitted to the front cross-bar or bolster may comply with subrule (2) (a) only, and
 - (b) the side marker lights fitted to the back cross-bar or bolster may comply with subrule (2) (b) only.

93 Side marker lights and rear clearance lights (cf ALVSR 2015 r 93; 2007 reg Sch 2 cl 106)

The side marker light nearest to the rear of a vehicle may also be a rear clearance light for the purposes of rule 89.

Division 10 Brake lights

94 Fitting brake lights (cf ALVSR 2015 r 94; 2007 reg Sch 2 cl 107)

- (1) A brake light must be fitted to the rear of a vehicle built after 1934.
- (2) A pair of brake lights must be fitted to the rear of:
 - (a) a motor vehicle built after 1 October 1991 that has 4 or more wheels, and
 - (b) a motor trike built after 1 October 1991 that has 2 rear wheels, and
 - (c) a trailer built after June 1973.
- (3) The centre of a brake light must be:
 - (a) at least 350 millimetres above ground level, and
 - (b) not over:
 - (i) 1.5 metres above ground level, or
 - (ii) if it is not practicable to fit the light lower—2.1 metres above ground level.
- (4) A vehicle may be fitted with 1 or more additional brake lights.
- (5) The centre of an additional brake light must be at least 350 millimetres above ground level.
- (6) If only 1 brake light is fitted to a vehicle, it must be fitted in the centre or to the right of the centre of the vehicle's rear.
- (7) Subrule (6) applies to a motor bike with an attached sidecar as if the sidecar were not attached.

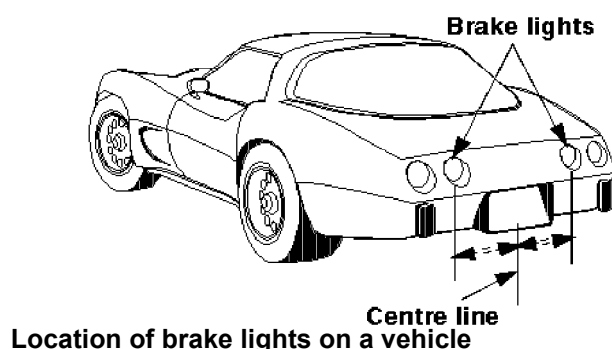

95 Performance and operation of brake lights (cf ALVSR 2015 r 95; 2007 reg Sch 2 cl 108)

- (1) When on, a brake light must show a red light visible 30 metres from the rear of the vehicle.
- (2) A brake light fitted to a street rod vehicle may incorporate a blue lens not over 20 millimetres in diameter.
- (3) A brake light fitted to a motor vehicle must come on, if it is not already on, when:
 - (a) for a vehicle with 4 or more wheels or built after 1974—a service brake is applied, or
 - (b) for another vehicle—the rear wheel brake is applied.
- (4) Subrule (3) does not apply if the controls in the vehicle that start the engine are in a position that makes it impossible for the engine to operate.
- (5) A brake light on a trailer must come on when:
 - (a) the brake light of the towing vehicle comes on, or
 - (b) a brake control on the towing vehicle, which independently activates the service brake on the trailer, is operated.
- (6) A brake light may be operated by an engine brake, retarder or similar device if the device does not interfere with the proper operation of the brake light.

Division 11 Reversing lights

96 Reversing lights (cf ALVSR 2015 r 96; 2007 reg Sch 2 cl 109)

- (1) One or more reversing lights may be fitted to the rear of a vehicle and on each side towards the rear of the vehicle.
- (2) A reversing light must have its centre not over 1.2 metres above ground level.
- (3) When on, a reversing light must show a white or yellow light to the rear or to the side and rear of the vehicle.

Note. Third edition ADRs only allow white reversing lights.
- (4) A reversing light fitted to a motor vehicle must be wired so it operates only when the vehicle is reversing or in reverse gear.
- (5) A reversing light fitted to a trailer must be wired so it operates only when a motor vehicle towing the trailer is reversing or in reverse gear.
- (6) A yellow reversing light may also operate as a direction indicator light.

Division 12 Direction indicator lights

97 Direction indicator lights on motor vehicles (cf ALVSR 2015 r 97; 2007 reg Sch 2 cl 110)

- (1) A motor vehicle with 4 or more wheels that was built after August 1966 must have:
 - (a) a pair of direction indicator lights fitted on, or towards, its front that face forwards, and
 - (b) a pair of direction indicator lights fitted on, or towards, its rear that face backwards.
- (2) A motor vehicle with less than 4 wheels that was built after June 1975 must have:
 - (a) a pair of direction indicator lights fitted on, or towards, its front that face forwards, and
 - (b) a pair of direction indicator lights fitted on, or towards, its rear that face backwards.
- (3) A motor vehicle that is not required to have direction indicator lights may have:
 - (a) 1 or more pairs of direction indicator lights that are visible from both the front and rear of the vehicle, or
 - (b) both:
 - (i) a pair of direction indicator lights fitted on, or towards, its front that face forwards, and
 - (ii) a pair of direction indicator lights fitted on, or towards, its rear that face backwards.

98 Direction indicator lights on trailers (cf ALVSR 2015 r 98; 2007 reg Sch 2 cl 111)

- (1) A trailer built after June 1973 must have a pair of direction indicator lights fitted on, or towards, its rear that face backwards.
- (2) A trailer that is not required to have direction indicator lights may have 1 or more pairs of direction indicator lights fitted on, or towards, its rear that face backwards.

99 Location of direction indicator lights (cf ALVSR 2015 r 99; 2007 reg Sch 2 cl 112)

- (1) A pair of direction indicator lights fitted to a vehicle must be spaced as follows:
 - (a) lights fitted to the front of a motor bike or the single wheel end of a motor trike must be spaced in accordance with the requirements for the position of front indicators set out in paragraph 6.3.3.1 of Appendix A to third edition ADR 19/02,
 - (b) lights fitted at the rear of a motor bike must be spaced in accordance with the requirements for the position of rear indicators set out in paragraph 6.3.3.1 of Appendix A to third edition ADR 19/02,
 - (c) lights fitted at the 2 wheel end of a motor trike must be spaced so that the centre of each light is at least 600 millimetres from the centre of the other light, unless the centre of each direction indicator light is not over 400 millimetres from the nearer side of the vehicle,
 - (d) lights fitted to another vehicle with a width of not over 1300 millimetres must be spaced so that the centre of each light is at least 400 millimetres from the centre of the other light,
 - (e) lights fitted to another vehicle with a width of over 1300 millimetres must be spaced so that the centre of each light is at least 600 millimetres from the centre of the other light.

- (2) Subrule (1) (a) and (b) apply to a vehicle even if it was built before the date stated in the ADR for vehicles of that type.
- (3) The centre of each direction indicator light must be at least 350 millimetres above ground level.
- (4) The centre of each light in a pair of direction indicator lights required to be fitted to a vehicle must not be over:
 - (a) 1.5 metres above ground level, or
 - (b) if it is not practicable for the light to be fitted lower—2.1 metres above ground level.

100 Operation and visibility of direction indicator lights (cf ALVSR 2015 r 100; 2007 reg Sch 2 cl 113)

- (1) A direction indicator light fitted to a motor vehicle must:
 - (a) when operating, display regular flashes of light at a rate of not over 120 flashes a minute, and:
 - (i) for a motor vehicle with 4 or more wheels—at least 60 flashes a minute, or
 - (ii) for any other motor vehicle—at least 45 flashes a minute, and
 - (b) be able to be operated by a person in the normal driving position, and
 - (c) be wired to an audible or visible device in the vehicle that tells the driver that the direction indicator light is operating, and
 - (d) flash at the same time and rate as any other direction indicator lights fitted on the same side of the vehicle.
 - (2) A direction indicator light fitted to a side of a trailer must, when operating, flash at the same time and rate as the direction indicator light or lights fitted to the same side of the motor vehicle towing the trailer.
 - (3) The flashes of light displayed by a direction indicator light must be:
 - (a) if the light faces forward—white or yellow, and
 - (b) if the light faces backwards:
 - (i) yellow, or
 - (ii) for a vehicle built before July 1973—yellow or red, and
 - (c) if the light faces out from the side of the vehicle:
 - (i) white or yellow towards the front and side, and
 - (ii) for a vehicle built before July 1973—yellow or red towards the rear and side, and
 - (iii) for a vehicle built after June 1973—yellow towards the rear and side.
- Note.** The ADRs only allow yellow direction indicator lights.
- (4) If a motor vehicle's direction indicator lights display only yellow light, the vehicle may be equipped to allow the lights to operate simultaneously on both sides of the vehicle, if a visible or audible signal tells the driver when the lights are operating simultaneously.
 - (5) When on, a direction indicator light must be visible 30 metres from:
 - (a) if the light faces forwards—the front of the vehicle, or
 - (b) if the light faces backwards—the rear of the vehicle, or
 - (c) if the light faces out from the side of the vehicle—that side of the vehicle.

- (6) When on, each direction indicator light in at least 1 pair of lights fitted on or towards the front of a prime mover, or a motor vehicle over 7.5 metres long, must be visible at a point:
 - (a) 1.5 metres at right angles from the side of the vehicle where the light is fitted, and
 - (b) in line with the rear of the vehicle.

Division 13 Fog lights

101 Front fog lights (cf ALVSR 2015 r 101; 2007 reg Sch 2 cl 114)

- (1) A pair of front fog lights may be fitted to a motor vehicle with 4 or more wheels.
- (2) A pair of front fog lights, or a single front fog light, may be fitted to a motor bike or trike.
- (3) A pair of front fog lights fitted to a motor vehicle with 4 or more wheels must have the centre of each light not over 400 millimetres from the nearer side of the vehicle unless the centres of the lights are at least 600 millimetres apart.
- (4) If the top of the front fog light is higher than the top of any low-beam headlight on the vehicle, the centre of the fog light must not be higher than the centre of the low-beam headlight.
- (5) A front fog light must:
 - (a) when on:
 - (i) project white or yellow light in front of the vehicle, and
 - (ii) be a low-beam light, and
 - (b) be able to be operated independently of any headlight, and
 - (c) be fitted so the light from it does not reflect off the vehicle into the driver's eyes.

102 Rear fog lights (cf ALVSR 2015 r 102; 2007 reg Sch 2 cl 115)

- (1) In this rule:
rear fog light means a light used on a vehicle to make it more easily visible, from the rear, in dense fog.
- (2) A vehicle may have fitted to its rear:
 - (a) a pair of rear fog lights, or
 - (b) 1 rear fog light fitted on, or to the right, of the centre of the vehicle.
- (3) Subrule (2) (b) applies to a motor bike with an attached sidecar as if the sidecar were not attached.
- (4) A rear fog light must:
 - (a) have its centre:
 - (i) not over 1.5 metres above ground level, and
 - (ii) at least 100 millimetres from the centre of a brake light, and
 - (b) when on, project red light behind the vehicle, and
 - (c) not use over 27 watts power, and
 - (d) be wired to a visible device in the vehicle that tells the driver that the rear fog light is operating.

Division 14 Interior lights

103 Interior lights (cf ALVSR 2015 r 103; 2007 reg Sch 2 cl 116)

A vehicle may be fitted with interior lights that illuminate any interior part of the vehicle.

Division 15 Reflectors generally

104 General requirements for reflectors (cf ALVSR 2015 r 104; 2007 reg Sch 2 cl 117)

- (1) A reflector fitted to a vehicle must show a red, yellow or white reflection of light when light is projected directly onto the reflector at night by a low-beam headlight that:
 - (a) is 45 metres from the reflector, and
 - (b) complies with these rules.
- (2) The reflection must be clearly visible from the position of the headlight.
- (3) A reflector may be in the form of reflecting sheeting or tape or other efficient reflecting material.

Division 16 Rear reflectors

105 Rear reflectors (cf ALVSR 2015 r 105; 2007 reg Sch 2 cl 118)

- (1) A motor vehicle with 4 or more wheels, and a trailer, must have a rear-facing red reflector towards each side of its rear.
- (2) A motor bike, a sidecar attached to a motor bike, and a motor trike, must have a rear-facing red reflector.
- (3) The centre of each reflector must be:
 - (a) at the same height above ground level, and
 - (b) not over 1.5 metres above ground level.
- (4) However, subrule (3) does not apply to a reflector fitted to a sidecar attached to a motor bike.
- (5) A reflector fitted to a motor vehicle with 4 or more wheels, or a trailer, must not be over 400 millimetres from the nearer side of the vehicle.
- (6) A vehicle fitted with rear-facing red reflectors in accordance with subrule (1) or (2) may be fitted with additional red reflectors at any height above ground level or at any distance from the side of the vehicle.

Division 17 Side reflectors

106 Compulsory side reflectors on pole-type trailers (cf ALVSR 2015 r 106; 2007 reg Sch 2 cl 119)

- (1) Yellow or red side-facing reflectors must be fitted to the pole of a pole-type trailer so:
 - (a) 1 reflector is fitted to the middle third of the left and right faces of the pole, and
 - (b) the front reflector is not over 3 metres from the front of the trailer, and
 - (c) the other reflectors are not over 3 metres apart.
- (2) Additional side-facing reflectors may be fitted to a pole-type trailer in accordance with rule 107.

107 Optional side reflectors (cf ALVSR 2015 r 107; 2007 reg Sch 2 cl 120)

- (1) A vehicle may be fitted with side-facing reflectors.
- (2) A side-facing reflector:
 - (a) towards the front of the vehicle must be yellow or white, and
 - (b) towards the rear of the vehicle must be yellow or red, and
 - (c) on the central part of the vehicle must be yellow.

Division 18 Front reflectors

108 Compulsory front reflectors on trailers (cf ALVSR 2015 r 108; 2007 reg Sch 2 cl 121)

- (1) A front-facing white or yellow reflector must be fitted towards each side of the front of:
 - (a) a semi-trailer, except a pole-type trailer, and
 - (b) the front cross-bar or bolster of a pole-type trailer, and
 - (c) a trailer that is at least 2.2 metres wide.
- (2) Each reflector must have its centre:
 - (a) at the same height above ground level, and
 - (b) not over 1.5 metres above ground level, and
 - (c) not over 400 millimetres from the nearer side of the vehicle.
- (3) Additional front-facing reflectors may be fitted to a trailer mentioned in subrule (1) in accordance with rule 109.

109 Optional front reflectors (cf ALVSR 2015 r 109; 2007 reg Sch 2 cl 122)

- (1) A motor vehicle with 4 or more wheels, or a trailer, may have 1 or more front-facing white or yellow reflectors fitted towards each side of its front.
- (2) A motor vehicle with less than 4 wheels may have 1 or more front-facing white or yellow reflectors.
- (3) The centre of at least 1 reflector on each side of the front of the vehicle must be:
 - (a) at the same height above ground level as the centre of the other reflector, and
 - (b) the same distance from the longitudinal axis of the vehicle as the centre of the other reflector, and
 - (c) at least:
 - (i) for a vehicle with a width under 1300 millimetres—400 millimetres from the centre of the other reflector, and
 - (ii) for another vehicle—600 millimetres from the centre of the other reflector.

Division 18A Spot and search lights

109A NSW rule: spot and search lights (cf 2007 reg Sch 2 cl 123)

A motor vehicle may be equipped with a spot or search light.

Division 19

110 Australian Light Vehicle Standards Rule not reproduced

* * * * *

Note. Rule 110 (Application of Division 19) of the *Australian Light Vehicle Standards Rules 2015* has not been reproduced in these rules. This rule has been left blank in order to preserve uniformity of numbering with the *Australian Light Vehicle Standards Rules 2015*.

111 Australian Light Vehicle Standards Rule not reproduced

* * * * *

Note. Rule 111 (Fitting of warning lights and signs) of the *Australian Light Vehicle Standards Rules 2015* has not been reproduced in these rules. This rule has been left blank in order to preserve uniformity of numbering with the *Australian Light Vehicle Standards Rules 2015*.

112 Australian Light Vehicle Standards Rule not reproduced

* * * * *

Note. Rule 112 (Operation and performance of warning lights) of the *Australian Light Vehicle Standards Rules 2015* has not been reproduced in these rules. This rule has been left blank in order to preserve uniformity of numbering with the *Australian Light Vehicle Standards Rules 2015*.

113 Australian Light Vehicle Standards Rule not reproduced

* * * * *

Note. Rule 113 (Specifications for warning signs) of the *Australian Light Vehicle Standards Rules 2015* has not been reproduced in these rules. This rule has been left blank in order to preserve uniformity of numbering with the *Australian Light Vehicle Standards Rules 2015*.

Division 20 Other lights, reflectors, rear marking plates or signals

114 Other lights and reflectors (cf ALVSR 2015 r 114; 2007 reg Sch 2 cl 124)

- (1) A vehicle may be fitted with any light or reflector not mentioned in these rules.
- (2) However, unless subrule (3) or (4) applies, a vehicle must not display or be fitted with:
 - (a) a light that flashes or rotates, or
 - (b) a light or reflector that:
 - (i) shows a red light to the front, or
 - (ii) shows a white light to the rear, or
 - (iii) is shaped or located in a way that reduces the effectiveness of a light or reflector that is required to be fitted to the vehicle under these rules, or
 - (iv) shows a blue light.
- (3) Despite rule 25B and any requirement of a third edition ADR, an emergency vehicle or police vehicle may be fitted with any light or reflector.
- (4) Despite rule 25B and any requirement of a third edition ADR, the following vehicles may be fitted with a light or lights, at least one of which must be mounted on top of the vehicle, capable of displaying a flashing or rotating light:
 - (a) ambulances,
 - (b) police vehicles,
 - (c) fire fighting vehicles,
 - (d) mines rescue or other rescue vehicles,
 - (e) Red Cross vehicles used for conveyance of blood for urgent transfusions,

- (f) public utility service vehicles,
 - (g) tow-trucks,
 - (h) motor breakdown service vehicles,
 - (i) vehicles used for the delivery of milk that are required to stop at frequent intervals,
 - (j) buses used solely or principally for the conveyance of children to or from school,
 - (k) vehicles exceeding the length, width and height limits of these rules,
 - (l) vehicles frequently used to transport loads that exceed the maximum length, width and height limits of these rules,
 - (m) vehicles used to escort vehicles referred to in paragraph (k) or (l),
 - (n) vehicles used by the Authority,
 - (o) vehicles used by an employee of a council of a local government area for the purposes of enforcing excess weight limits legislation,
 - (p) State Emergency Service vehicles,
 - (q) any other vehicles that are approved by the Authority.
- (5) Despite subrule (4), a police vehicle is not required to have a light mounted on top of the vehicle.
- (6) Despite subrule (4), a vehicle used by the Authority is not required to have a light mounted on top of the vehicle.
- (7) A light that may be fitted under subrule (4) must be capable of displaying:
- (a) in the case of a police vehicle, an ambulance, a fire fighting vehicle, a vehicle used by a Traffic Commander or Traffic Emergency Patroller (appointed or employed by the Authority), a State Emergency Service vehicle or a vehicle used by an accredited rescue unit (within the meaning of the *State Emergency and Rescue Management Act 1989*)—a blue or red light, or
 - (b) in the case of a Red Cross vehicle, a mines rescue or other rescue vehicle or an emergency vehicle within the meaning of the *Road Rules 2014* (other than a vehicle referred to in paragraph (a))—a red light, or
 - (c) in the case of a vehicle used by the Authority or a vehicle used by a council of a local government area for the purposes of enforcing excess weight limits legislation—a crimson light, or
 - (d) in the case of a fire brigade emergency site command vehicle—a green light, or
 - (e) in the case of any other vehicle—a yellow light unless otherwise approved by the Authority.
- (8) The lens of any such light must not be visible, either directly or indirectly, to the driver of the motor vehicle or trailer to which it is fitted when that driver is seated in the normal driving position.
- (9) The light from any such light mounted on the top of the vehicle must be visible in normal sunlight from a distance of at least 200 metres to a driver approaching that vehicle from any direction.
- (10) Subrule (7) does not apply to the extent that it is inconsistent with a requirement of Part 3A or clause 148 of the *Road Transport (General) Regulation 2013* relating to oversize vehicles or pilot or escort vehicles.

- (11) In this rule, ***excess weight limits legislation*** means:
- (a) the *Heavy Vehicle National Law (NSW)*, or
 - (b) Part 3A and clause 148 of the *Road Transport (General) Regulation 2013*.

114A NSW rule: flashing direction indicator lights (cf 2007 reg Sch 2 cl 125)

- (1) A motor vehicle that:
- (a) is specified in rule 114 (4), and
 - (b) has direction indicator lights that show yellow light to the front,
- may be equipped with a device that will cause the direction indicator lights fitted to the front and rear and on both sides of the vehicle, and any trailer connected to the vehicle, to flash simultaneously and regularly at a rate of not less than 60 and not more than 120 flashes per minute.
- (2) When all such lights fitted to a motor vehicle and trailer (if any) are flashing simultaneously, there must be an indicator that will inform the driver, by visible and audible means, that the lights are flashing.

114B NSW rule: flashing lights on other vehicles—street vending vehicles (cf 2007 reg Sch 2 cl 126)

Street vending vehicles must be fitted with a flashing warning light mounted on the roof of the vehicle. Any such light must:

- (a) be capable of displaying a rotating, flashing, yellow coloured light, and
- (b) commence to emit light within 1 second of being switched on, and
- (c) when switched on, flash regularly at a rate of not less than 60 times per minute, and
- (d) be connected to an indicator that will inform the driver, by visible and audible means, that the light is flashing, and
- (e) emit light that is visible in normal sunlight from a distance of at least 200 metres to a driver approaching the vehicle from any direction.

115 Rear marking plates (cf ALVSR 2015 r 115; 2007 reg Sch 2 cl 127)

- (1) In this rule:
- rear marking plate*** means a rear marking plate complying with Vehicle Standards Bulletin VSB 12.

Note. The Vehicle Standard Bulletins provide information on the design, manufacture, sale, modification, maintenance, import and repair of road vehicles. The term 'road vehicles' includes both motor vehicles and trailers. The Bulletins are available from the Commonwealth Department of Infrastructure and Regional Development.
(See https://infrastructure.gov.au/roads/vehicle_regulation/bulletin/)

- (2) Rear marking plates may be fitted to:
- (a) a motor vehicle, or
 - (b) a trailer.

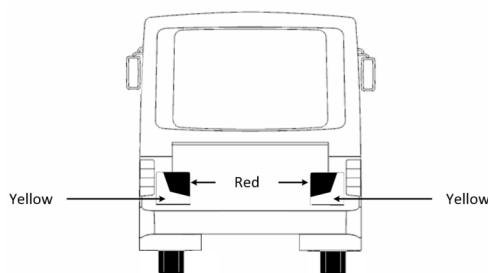

Location of tail lights on a vehicle

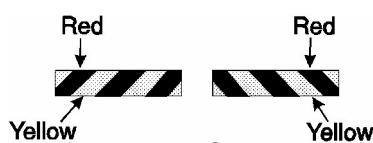

An alternative pattern for rear marking plates

116 Signalling devices (cf ALVSR 2015 r 116; 2007 reg Sch 2 cl 128)

- (1) This rule applies to a motor vehicle if:
 - (a) the vehicle is not fitted with a brake light or direction indicator light mentioned in Division 10 or 12, and
 - (b) the construction of the vehicle would otherwise prevent the driver from hand signalling an intention:
 - (i) to turn or move the vehicle to the right, or
 - (ii) to stop or suddenly reduce the speed of the vehicle.
- (2) The vehicle must be fitted with a mechanical signalling device or a pair of turn signals.

117 Mechanical signalling devices (cf ALVSR 2015 r 117; 2007 reg Sch 2 cl 129)

- (1) A mechanical signalling device must:
 - (a) be fitted to the right side of the vehicle, and
 - (b) be able to be operated by the driver from a normal driving position, and
 - (c) consist of a white or yellow representation of an open human hand at least 15 centimetres long, and
 - (d) be constructed so that the driver of the vehicle can keep the device:
 - (i) in a neutral position so it is unlikely that the driver of another vehicle or anyone else would regard it as a signal, and
 - (ii) in a horizontal position with the palm of the hand facing forwards and the fingers pointing out at a right angle to the vehicle to signal an intention to turn or move right, and
 - (iii) with the palm of the hand facing forwards and the fingers pointing upwards to signal an intention to stop or reduce speed suddenly.
- (2) When the mechanical signalling device is in a position mentioned in subrule (1) (d) (ii) or (iii), the complete hand must be clearly visible, from both the front and the rear of the vehicle, at a distance of 30 metres.

118 Turn signals (cf ALVSR 2015 r 118; 2007 reg Sch 2 cl 130)

A turn signal must:

- (a) consist of a steady or flashing illuminated yellow sign at least 15 centimetres long and 25 millimetres wide that:
 - (i) when in operation—is kept horizontal, and
 - (ii) when not in operation—is kept in a position so it is unlikely that the driver of another vehicle or anyone else would regard it as a signal, and
- (b) be fitted to the side of the motor vehicle at least 50 centimetres and not over 2.1 metres above ground level, in a position so the driver of the vehicle, from the normal driving position, can see whether the signal is in operation, and
- (c) be able to be operated by the driver from the normal driving position, and
- (d) when in operation, be visible from both the front and rear of the vehicle at a distance of 30 metres.

Part 8 Braking systems

Note. This Part sets out the braking system requirements for vehicles to ensure that they can be reliably slowed or stopped even if a part of a braking system fails, and to ensure that a vehicle can be prevented from rolling away when parked.

Division 1 Brake requirements for all vehicles

119 Components of a braking system (cf ALVSR 2015 r 119; 2007 reg Sch 2 cl 133)

- (1) A brake tube or hose fitted to a vehicle must:
 - (a) be manufactured from a material appropriate to its intended use in the vehicle, and
 - (b) be long enough to allow for the full range of steering and suspension movements of the vehicle, and
 - (c) be fitted to prevent it being damaged during the operation of the vehicle by:
 - (i) a source of heat, or
 - (ii) any movement of the parts to which it is attached or near.
- (2) Each component of the braking system of a vehicle must comply with the design and performance requirements of:
 - (a) a relevant Australian Standard or British Standard as in force when this subrule commenced, or
 - (b) a relevant standard approved by any of the following bodies, and as in force when this subrule commenced:
 - (i) American Society of Automotive Engineers,
 - (ii) American National Standards Institute,
 - (iii) Japanese Standards Association,
 - (iv) Deutsches Institut für Normung,
 - (v) International Organization for Standardization.

120 Provision for wear (cf ALVSR 2015 r 120; 2007 reg Sch 2 cl 134)

The braking system of a vehicle must allow for adjustment to take account of normal wear.

121 Supply of air or vacuum to brakes (cf ALVSR 2015 r 121; 2007 reg Sch 2 cl 135)

- (1) If air brakes are fitted to a vehicle:
 - (a) the compressor supplying air to the brakes must be able to build up air pressure to at least 80% of the governor cut-out pressure in not over 5 minutes after the compressed air reserve is fully used up, and
 - (b) there must be an automatic or manual condensate drain valve at the lowest point of each air brake reservoir in the system, and
 - (c) any spring brake fitted to the vehicle must not operate before the warning mentioned in rule 128 (3) (a) has been given.
- (2) If vacuum brakes are fitted to a vehicle, the vacuum supply must be able to build up vacuum:
 - (a) to the level when the warning signal mentioned in rule 128 (3) (a) no longer operates within 30 seconds after the vacuum reserve is fully used up, and
 - (b) to the normal working level within 60 seconds after the vacuum reserve is fully used up.

122 Performance of braking systems (cf ALVSR 2015 r 122; 2007 reg Sch 2 cl 136)

- (1) One sustained application of the brake of a motor vehicle built after 1930, or a combination that includes a motor vehicle built after 1930, must be able to produce the performance mentioned in subrules (2)–(7):
 - (a) when the vehicle or combination is on a dry, smooth, level road surface, free from loose material, and
 - (b) whether or not the vehicle or combination is loaded, and
 - (c) without part of the vehicle or combination moving outside a straight path:
 - (i) centred on the longitudinal axis of the vehicle or combination before the brake was applied, and
 - (ii) 3.7 metres wide.
- (2) The braking system of a motor vehicle or combination with a gross mass under 2.5 tonnes must bring the vehicle or combination from a speed of 35 kilometres an hour to a stop within:
 - (a) 12.5 metres when the service brake is applied, and
 - (b) 30 metres when the emergency brake is applied.
- (3) The braking system of a motor vehicle or combination with a gross mass of at least 2.5 tonnes must bring the vehicle or combination from a speed of 35 kilometres an hour to a stop within:
 - (a) 16.5 metres when the service brake is applied, and
 - (b) 40.5 metres when the emergency brake is applied.
- (4) The braking system of a motor vehicle or combination with a gross mass under 2.5 tonnes must decelerate the vehicle or combination, from any speed at which the vehicle or combination can travel, by an average of at least:
 - (a) 3.8 metres per second per second when the service brake is applied, and
 - (b) 1.6 metres per second per second when the emergency brake is applied.
- (5) The braking system of a motor vehicle or combination with a gross mass of at least 2.5 tonnes must decelerate the vehicle or combination, from any speed at which the vehicle or combination can travel, by an average of at least:
 - (a) 2.8 metres per second per second when the service brake is applied, and

- (b) 1.1 metres per second per second when the emergency brake is applied.
- (6) The braking system of a motor vehicle or combination with a gross mass under 2.5 tonnes must achieve a peak deceleration of the vehicle or combination, from any speed at which the vehicle or combination can travel, of at least:
 - (a) 5.8 metres per second per second when the service brake is applied, and
 - (b) 1.9 metres per second per second when the emergency brake is applied.
- (7) The braking system of a motor vehicle or combination with a gross mass of at least 2.5 tonnes must achieve a peak deceleration of the vehicle or combination, from any speed at which the vehicle or combination can travel, of at least:
 - (a) 4.4 metres per second per second when the service brake is applied, and
 - (b) 1.5 metres per second per second when the emergency brake is applied.
- (8) The parking brake of a vehicle or combination must be able to hold the vehicle or combination stationary on a 12% gradient:
 - (a) when the vehicle or combination is on a dry, smooth road surface, free from loose material, and
 - (b) whether or not the vehicle or combination is loaded.

Division 2 Motor vehicle braking systems

123 What braking system a motor vehicle must have (cf ALVSR 2015 r 123; 2007 reg Sch 2 cl 137)

- (1) In this rule:
 - independent brake*, for a vehicle, means a brake that is operated entirely separately from any other brake on the vehicle, except for any drum, disc or part, on which a shoe, band or friction pad makes contact, that is common to 2 or more brakes.
- (2) A motor vehicle with 4 or more wheels built, or used, mainly for transporting goods or people by road must be fitted with:
 - (a) a braking system that:
 - (i) consists of brakes fitted to all wheels of the vehicle, and
 - (ii) has at least 2 separate methods of activation, arranged so effective braking remains on at least 2 wheels if a method fails, or
 - (b) 2 independent brakes, each of which, when in operation, acts directly on at least half the number of wheels of the vehicle.
- (3) The braking system of a motor vehicle mentioned in subrule (2) that was built after 1945 must have a service brake operating on all wheels that, when applied:
 - (a) acts directly on the wheels and not through the vehicle's transmission, or
 - (b) acts on a shaft between a differential of the vehicle and a wheel.
- (4) The braking system of a motor vehicle with 4 or more wheels must have a parking brake that:
 - (a) is held in the applied position by direct mechanical action without the intervention of an electrical, hydraulic or pneumatic device, and
 - (b) is fitted with a locking device that can hold the brake in the applied position, and
 - (c) has its own separate control.
- (5) The parking brake may also be the emergency brake.

- (6) If 2 or more independent brakes are fitted to a motor vehicle with 4 or more wheels, the brakes must be arranged so brakes are applied to all the wheels on at least 1 axle of the vehicle when any brake is operated.
- (7) A motor bike or motor trike must be fitted with:
 - (a) 2 independent brakes, or
 - (b) a single brake that acts directly on all wheels of the vehicle and is arranged so effective braking remains on at least 1 wheel if a part of the system fails.
- (8) Subrule (7) applies to a motor bike with a sidecar attached as if the sidecar were not attached.
- (9) A motor trike must have a parking brake that is held in the applied position by mechanical means.

124 Operation of brakes on motor vehicles (cf ALVSR 2015 r 124; 2007 reg Sch 2 cl 138)

The braking system on a motor vehicle must be arranged to allow the driver of the motor vehicle to apply the brakes from a normal driving position.

125 Air or vacuum brakes on motor vehicles (cf ALVSR 2015 r 125; 2007 reg Sch 2 cl 139 (1)–(5))

- (1) If a motor vehicle has air brakes, the braking system of the vehicle must include at least 1 air storage tank.
- (2) If a motor vehicle has vacuum brakes, the braking system of the vehicle must include at least 1 vacuum storage tank.
- (3) An air or vacuum storage tank must be built so the service brake can be applied to meet the performance standards of rule 122 at least twice if the engine of the vehicle stops or the source of air or vacuum fails.
- (4) An air or vacuum storage system must be safeguarded by a check valve or other device against loss of air or vacuum if the supply fails or leaks.

125A NSW rule: air or vacuum brakes on motor vehicles equipped to tow trailers (cf 2007 reg Sch 2 cl 139 (6)–(8))

- (1) If air or vacuum brakes are fitted to a motor vehicle equipped to tow a trailer, the brakes of the vehicle must be able to stop the vehicle at the performance standards for emergency brakes under rule 122 if the trailer breaks away.
- (2) The braking system of a motor vehicle equipped to tow a trailer fitted with air brakes must include protection against loss of supply line air or brake control signal air.
- (3) The protection mentioned in subrule (2) must:
 - (a) operate automatically if a brake supply line hose connecting the motor vehicle and a trailer fails, and
 - (b) maintain enough air pressure to allow the brakes to be applied to meet performance standards for emergency brakes under rule 122, and
 - (c) include a visible or audible warning to the driver.

Division 3 Trailer braking systems

126 What brakes a trailer must have (cf ALVSR 2015 r 126; 2007 reg Sch 2 cl 140)

- (1) A trailer with a GTM over 750 kilograms must have brakes that operate on at least 1 wheel at each end of 1 or more axles of the trailer.

- (2) A semi-trailer or converter dolly with a GTM over 2 tonnes must have brakes that operate on all its wheels.

127 Operation of brakes on trailers (cf ALVSR 2015 r 127; 2007 reg Sch 2 cl 141)

- (1) The braking system of a trailer with a GTM over 2 tonnes must allow the driver of a motor vehicle towing the trailer to operate the brakes from a normal driving position.
- (2) The brakes on a trailer with a GTM over 2 tonnes must:
 - (a) operate automatically and quickly if the trailer breaks away from the towing vehicle, and
 - (b) remain in operation for at least 15 minutes after a break-away, and
 - (c) be able to hold the trailer on a 12% gradient while in operation after a break-away.

128 Air or vacuum brakes on trailers (cf ALVSR 2015 r 128; 2007 reg Sch 2 cl 142)

- (1) If a trailer has air brakes, its braking system must include at least 1 air storage tank.
- (2) If a trailer has vacuum brakes, its braking system must include at least 1 vacuum storage tank.
- (3) An air or vacuum storage system must:
 - (a) be built to give a visible or audible warning to the driver of the towing vehicle, while in a normal driving position, of a lack of air or vacuum that would prevent the brakes from meeting the performance standards of rule 122, and
 - (b) be safeguarded by a check valve or other device against loss of air or vacuum if the supply fails or leaks.
- (4) Subrules (1), (2) and (3) do not apply to a trailer with a GTM of 2 tonnes or less.

Part 9 Control of emissions

Note. This Part sets out requirements to ensure that motor vehicles do not emit too much smoke or noise and that exhaust gases cannot enter the passenger compartment of a vehicle.

Division 1 Crank case gases and exhaust emissions

129 Crank case gases (cf ALVSR 2015 r 129; 2007 reg Sch 2 cl 154)

- (1) This rule applies to a motor vehicle with 4 or more wheels that is powered by a petrol engine and was built after 1971.
- (2) The vehicle must be built to prevent, or fitted with equipment that prevents, crank case gases from escaping to the atmosphere.

130 Visible emissions—vehicles with internal combustion engines (cf ALVSR 2015 r 130; 2007 reg Sch 2 cl 155)

- (1) This rule applies to a motor vehicle that is propelled by an internal combustion engine and was built after 1930.
- (2) The vehicle must not emit visible emissions for a continuous period of at least 10 seconds.
- (3) However, this rule does not apply to emissions that are visible only because of heat or the condensation of water vapour.

Division 2 Exhaust systems

131 Australian Light Vehicle Standards Rule not reproduced

* * * * *

Note. Rule 131 (Exhaust emissions—diesel-powered vehicles) of the *Australian Light Vehicle Standards Rules 2015* has not been reproduced in these Rules. This rule has been left blank in order to preserve uniformity of numbering with the *Australian Light Vehicle Standards Rules 2015*.

132 Australian Light Vehicle Standards Rule not reproduced

* * * * *

Note. Rule 132 (Requirements of DT 80 test cycle) of the *Australian Light Vehicle Standards Rules 2015* has not been reproduced in these Rules. This rule has been left blank in order to preserve uniformity of numbering with the *Australian Light Vehicle Standards Rules 2015*.

133 Australian Light Vehicle Standards Rule not reproduced

* * * * *

Note. Rule 133 (Test procedure) of the *Australian Light Vehicle Standards Rules 2015* has not been reproduced in these Rules. This rule has been left blank in order to preserve uniformity of numbering with the *Australian Light Vehicle Standards Rules 2015*.

134 Exhaust systems (cf ALVSR 2015 r 134; 2007 reg Sch 2 cl 156)

(1) In this rule:

vertical exhaust system means an exhaust system that emits exhaust gases in an upward direction above or near the top of a vehicle to which the exhaust system is fitted.

(2) An outlet (a **motor trike exhaust outlet**) of an exhaust system fitted to a motor trike with a permanently enclosed body must extend:

- (a) at least 40 millimetres beyond the outermost joint of the floorpan that is not continuously welded or permanently sealed, and
- (b) not beyond the perimeter of the vehicle.

(3) The motor trike exhaust outlet must discharge the main exhaust flow to the air:

- (a) if the outlet is fitted to the side of the motor trike—to the right hand side of the motor trike and below the horizontal axis of the motor trike at an angle between 15 degrees and 45 degrees, or
- (b) if the outlet is fitted to the rear of the motor trike—at an angle between 10 degrees above the horizontal axis of the motor trike and 45 degrees below that axis.

(4) An outlet (a **bus exhaust outlet**) of an exhaust system fitted to a bus must be as near as practicable to the rear of the bus.

(5) If the bus is not fitted with a vertical exhaust system, the bus exhaust outlet must not extend beyond the perimeter of the bus.

(6) If the bus is fitted with a vertical exhaust system, the bus exhaust outlet must be located behind the rearmost part of the passenger compartment.

(7) A bus exhaust outlet must discharge the main exhaust flow to the air:

- (a) if the outlet is not part of a vertical exhaust system:
 - (i) towards the rear, or to the right, of the bus, and
 - (ii) horizontally or downwards at an angle not more than 45 degrees below the horizontal axis, or

- (b) if the outlet is part of a vertical exhaust system—vertically upwards or towards the rear of the bus at any angle above the horizontal axis.
- (8) An exposed section of a vertical exhaust system fitted to a motor vehicle (except a bus) must be positioned or shielded to prevent injury.

Division 3 Noise emissions

Subdivision 1 General

135 Measurement of stationary noise levels (cf ALVSR 2015 r 135; 2007 reg Sch 2 cl 161)

- (1) For this Division, the stationary noise level of a motor vehicle is to be measured in accordance with the procedure set out for the kind of vehicle in the *National Stationary Exhaust Noise Test Procedures for In-Service Motor Vehicles—September 2006* (ISBN: 1 921168 50 1) published by the Commission.
- (2) In subrule (1), **Commission** means the National Transport Commission established by the *National Transport Commission Act 2003* of the Commonwealth.
Note. The *National Stationary Exhaust Noise Test Procedures for In-Service Motor Vehicles—September 2006* is available on the Commission’s website at www.ntc.gov.au.

136 Meaning of “certified to ADR 83/00” (cf ALVSR 2015 r 136)

For this Division, a vehicle is **certified to ADR 83/00** if approval has been given, under section 10A of the Motor Vehicle Standards Act, to place identification plates showing compliance with ADR 83/00 on vehicles of that type.

137 Silencing device for exhaust systems (cf ALVSR 2015 r 137; 2007 reg Sch 2 cl 157)

- (1) A motor vehicle propelled by an internal combustion engine must be fitted with a silencing device through which all the exhaust from the engine passes.
- (2) For subrule (1), any silencing device designed to be manipulated by the vehicle’s operator, such as by means of in-vehicle controls, must be designed so that it can be tested with the device in its loudest setting.

Subdivision 2 Noise levels applying to vehicles certified prior to the application of ADR 83/00

138 Application of rules in Subdivision 2 (cf ALVSR 2015 r 138)

This Subdivision applies to a motor vehicle other than a vehicle certified to ADR 83/00.

139 Stationary noise levels—car-type vehicles and motor bikes and motor trikes

(cf ALVSR 2015 r 139; 2007 reg Sch 2 cl 158)

- (1) In this rule:
car-type vehicle means:
 - (a) a car, or
 - (b) a utility truck, panel van, or another motor vehicle derived from a car design, or
 - (c) another motor vehicle with 4 or more wheels that is built mainly to carry not over 9 people including the driver.
- (2) The stationary noise level of a car-type vehicle, or motor bike or motor trike, must not exceed:
 - (a) for a car-type vehicle built after 1982—90 dB(A), or

- (b) for another car-type vehicle—96 dB(A), or
- (c) for a motor bike or motor trike built after February 1985—94 dB(A), or
- (d) for another motor bike or motor trike—100 dB(A).

140 Stationary noise levels—other vehicles with spark ignition engines (cf ALVSR 2015 r 140; 2007 reg Sch 2 cl 159)

- (1) This rule applies to a motor vehicle (except a motor vehicle to which rule 139 applies) with a spark ignition engine.
- (2) The stationary noise level of the motor vehicle must not exceed the noise level applying to the vehicle under the table.

Column 1 Item	Column 2 GVM (t)	Column 3 Exhaust height (mm)	Column 4 When vehicle built	Column 5 Noise level (dB(A))
1	≤3.5	<1500	before July 1983	92
			after June 1983	89
2	>3.5	<1500	before July 1983	98
			after June 1983	95
3	≤3.5	≥1500	before July 1983	88
			after June 1983	85
4	>3.5	≥1500	before July 1983	94
			after June 1983	91

141 Stationary noise levels—other vehicles with diesel engines (cf ALVSR 2015 r 141; 2007 reg Sch 2 cl 160)

- (1) This rule applies to a motor vehicle (except a motor vehicle to which rule 139 applies) with a diesel engine.
- (2) The stationary noise level of the motor vehicle must not exceed the noise level applying to the vehicle under the table.

Column 1 Item	Column 2 GVM (t)	Column 3 Exhaust height (mm)	Column 4 When vehicle built	Column 5 Noise level (dB(A))
1	≤3.5	<1500	before July 1980	105
			after June 1980 but before July 1983	102
			after June 1983	99
2	>3.5	<1500	before July 1980	107
			after June 1980 but before July 1983	104
			after June 1983	101

Column 1 Item	Column 2 GVM (t)	Column 3 Exhaust height (mm)	Column 4 When vehicle built	Column 5 Noise level (dB(A))
3	≤3.5	≥1500	before July 1980	101
			after June 1980 but before July 1983	98
			after June 1983	95
4	>3.5	≥1500	before July 1980	103
			after June 1980 but before July 1983	100
			after June 1983	97

Subdivision 3 Noise levels applying to vehicles certified to ADR 83/00

142 Stationary noise levels (cf ALVSR 2015 r 142)

The stationary noise level of a motor vehicle that is certified to ADR 83/00 must not exceed, by more than 5 dB(A), the noise level that is established for the motor vehicle when it is certified.

Part 10 Alternative fuel systems

Note. This Part sets out requirements to ensure that LPG (Liquid Petroleum Gas) and natural gas fuel systems are safely installed in motor vehicles and that vehicles with LPG or natural gas fuel systems installed can be identified as LPG-powered vehicles or vehicles powered by natural gas.

143 LPG-powered vehicles (cf ALVSR 2015 r 143; 2007 reg Sch 2 cl 162 (1) and (2))

- (1) An LPG system installed in a motor vehicle, and the vehicle, must comply with all relevant requirements set out in the version of Australian Standard AS 1425 that was current at the time the system was installed in the vehicle.
- (2) A motor vehicle that has an LPG system installed must have fixed conspicuously to the front and rear number-plates a label:
 - (a) that is made of durable material, and
 - (b) that is at least 25 millimetres wide and 25 millimetres high, and
 - (c) that is of retroreflective red conforming to Australian and New Zealand Standard AS/NZS 1906.1:2007 *Retroreflective materials and devices for road traffic control purposes—Retroreflective sheeting*, and
 - (d) that is marked “LPG” in white capital letters at least 10 millimetres high.

144 Vehicles powered by natural gas (cf ALVSR 2015 r 144; 2007 reg Sch 2 cl 162 (3) and (4))

- (1) A natural gas system installed in a motor vehicle, and the vehicle, must comply with all relevant requirements set out in the version of Australian Standard AS 2739 that was current at the time the system was installed in the vehicle.
Examples. Forms of natural gas include CNG (Compressed Natural Gas) and LNG (Liquid Natural Gas).
- (2) A motor vehicle that has a natural gas system installed must have fixed conspicuously to the front and rear number-plates a label:
 - (a) that is made of durable material, and
 - (b) that is circular with a diameter of at least 35 millimetres, and

- (c) that is of retroreflective red conforming to Australian and New Zealand Standard AS/NZS 1906.1:2007 *Retroreflective materials and devices for road traffic control purposes—Retroreflective sheeting*, and
- (d) that is marked “CNG” in white capital letters at least 10 millimetres high.

Part 11 Mechanical connections between vehicles

Note. This Part sets out various requirements to ensure that the couplings used when operating motor vehicles and trailers in combinations are strong enough to hold them together.

145 General coupling requirements (cf ALVSR 2015 r 145; 2007 reg Sch 2 cl 165)

- (1) A fifth wheel coupling, the mating parts of a coupling, a kingpin or a towbar must not be used for a load more than the manufacturer’s load rating.
- (2) A kingpin must be used only with a fifth wheel coupling that has a corresponding jaw size.
Example. An adaptor must not be used to fit a kingpin to a fifth wheel coupling.
- (3) The mating parts of a coupling used to connect a semi-trailer to a towing vehicle must not allow the semi-trailer to roll to an extent that makes the towing vehicle unstable.

146 Drawbar couplings (cf ALVSR 2015 r 146; 2007 reg Sch 2 cl 166)

- (1) A coupling for attaching a trailer, except a semi-trailer or pole-type trailer, to a towing vehicle must be built and fitted so that:
 - (a) the coupling is equipped with a positive locking mechanism, and
 - (b) the positive locking mechanism can be released regardless of the angle of the trailer to the towing vehicle.
- (2) A coupling fitted to a trailer first registered on or after 1 August 1963 must have clearly and permanently stamped, moulded or otherwise branded on its main component:
 - (a) means of identifying its manufacturer, and
 - (b) the maximum gross weight of the trailer it is designed to tow.
- (3) If the trailer is in a combination and is not fitted with break-away brakes in accordance with rule 127 (2), it must be connected to the towing vehicle by at least 1 chain, cable or other flexible device, as well as the coupling required by subrule (1).
- (4) Any such safety connection must be as short as practicable and be so connected and affixed that:
 - (a) it is not liable to accidental disconnection but is readily detachable from the towing vehicle, and
 - (b) it permits all normal angular movements of the coupling without more slack than is necessary, and
 - (c) it will prevent the forward end of the drawbar from striking the ground in the event of accidental disconnection of the coupling, and
 - (d) if it consists of more than 1 chain or wire rope, the chains or wire ropes are in a crossed-over position, and
 - (e) the trailer is kept in tow if the coupling breaks or accidentally detaches.
- (5) For the purposes of subrule (4), a safety connection between a trailer and a towing vehicle includes anything which connects the trailer and the towing vehicle.

Examples of what is included in a safety connection:

- chains
- cables

- a thing fixed to a trailer or a towing vehicle to which a chain is attached
 - shackles
- (6) Any chain or wire rope in such a safety connection must:
- (a) if a chain, be of welded iron links, and
 - (b) if a wire rope, have a strength of at least that of a chain of the same diameter, and
 - (c) be of a size specified in the following table:

Table

Gross weight of trailer	Minimum size of chain or wire rope
Up to 500 kilograms	6.3 millimetres diameter
Exceeding 500 kilograms but not exceeding 1.3 tonnes	9.5 millimetres diameter
Exceeding 1.3 tonnes	12.6 millimetres diameter

Part 11A Special provisions for buses not subject to third edition ADRs

Division 1 General

146A NSW rule: application of Part (cf 2007 reg Sch 2 cl 184)

This Part applies to all buses except those buses required by these rules to be constructed and equipped so as to comply with the third edition ADRs.

146B NSW rule: requirements of this Part additional to other provisions of Light Vehicle Standards Rules (cf 2007 reg Sch 2 cl 185)

- (1) In addition to complying with the other provisions of these rules, a bus must be constructed or equipped with the items of equipment set out in this Part.
- (2) The Authority may approve of a modification of all or any of the provisions of Division 2 in the case of a bus equipped to seat not more than 12 adults including the driver and used or intended to be used for the conveyance of school children or children with disabilities or employees of the owner or for a similar purpose if the Authority is satisfied that it is so constructed and equipped that it is safe to be used for that purpose.

Division 2 Additional requirements for buses

146C NSW rule: driver's guard-rail (cf 2007 reg Sch 2 cl 186)

Where necessary, there must be a suitable guard-rail or panel fitted to a bus:

- (a) that will prevent any passenger from accidentally coming into contact with the driver or the control levers of the vehicle, and
- (b) that will prevent any passenger from obstructing the driver's view.

146D NSW rule: inside mirror (cf 2007 reg Sch 2 cl 187)

A mirror must be suitably affixed to the inside of a bus that has such dimensions and is so affixed that it will reflect to the driver, while retaining his or her normal driving position, a view of doors and door approaches of the vehicle.

146E NSW rule: fuel tank (cf 2007 reg Sch 2 cl 188)

- (1) The fuel tank and the fuel tank filler pipe must not be located in the interior of the bus, in the engine compartment, or in any separate compartment for the driver.
- (2) The fuel tank filler pipe must be situated so that it is not less than 900 millimetres from either side of any exit (including any emergency exit) and must be arranged so that any overflow or leakage of fuel cannot accumulate.

146F NSW rule: emergency exits for buses (cf 2007 reg Sch 2 cl 189)

- (1) In the case of a single-deck bus not provided for in subrule (2), there must be:
 - (a) at least 1 emergency exit at the extreme rear of the passenger compartment measuring not less than 1.3 metres by 530 millimetres, or
 - (b) at least 1 emergency exit fitted in the roof of the rear half of the passenger compartment having a minimum area of 7000 square centimetres and no dimension less than 530 millimetres and, in the case of a bus first registered on or after 1 January 1963 that does not have a door accessible to passengers fitted in each side of the vehicle, there must be located in the rear half of the passenger compartment on the side on which a door is not fitted, an emergency exit measuring not less than 600 millimetres by 530 millimetres.
- (2) In the case of a single-deck bus with its engine or any other obstruction at its rear, there must be an emergency exit as prescribed in subrule (1) (b) near the centre of the passenger compartment.
- (3) At the rear of a double-deck bus there must be at least 2 emergency exits, 1 situated above and the other below the level of the floor of the upper deck. Any such exit must measure not less than 1.3 metres by 530 millimetres.
- (4) However, it is sufficient compliance with subrule (3) if:
 - (a) the bus is fitted with a rear platform, and
 - (b) access from outside the vehicle to the platform extends transversely across the rear of the bus for a distance of not less than 450 millimetres, and
 - (c) there is at the rear of the bus at least 1 emergency exit situated above the level of the floor of the upper deck complying in other respects with the requirements of subrule (3).
- (5) Any emergency exit:
 - (a) must be clear of any obstruction, and
 - (b) must, where necessary, be equipped inside and outside with a suitable opening and closing device, and
 - (c) must be indicated by a prominent notice inside and outside the bus displaying the words "Emergency Exit".

146G NSW rule: fire extinguishers (cf 2007 reg Sch 2 cl 190)

- (1) Every bus must be equipped with the number of fire extinguishers required by the Authority, being fire extinguishers of a type and capacity approved by the Authority.
- (2) A fire extinguisher with which a bus is equipped:
 - (a) must be maintained in good order and condition, and
 - (b) must be kept in a position where it is readily available for use.

146H NSW rule: removable and opening interior fittings (cf 2007 reg Sch 2 cl 191)

Every hatch, cover, interior door and other removable or opening panel in the interior of a bus must be adequately secured to prevent the likelihood of accidental opening or dislodgment.

Schedule 3 Fees

(Clause 124 (1) (a))

Matter for which fee payable	Fee (\$)
Part 1 Registration or renewal of registration of a motor vehicle or trailer	
(a) Motor lorry (other than an articulated motor lorry or prime mover) with a GVM of 12 tonnes or more:	
(i) for more than 6 months but not more than 1 year	286
(ii) for more than 3 months but not more than 6 months	143
(iii) for 3 months or less	71
(b) Articulated motor lorry:	
(i) for more than 6 months but not more than 1 year	428
(ii) for more than 3 months but not more than 6 months	214
(iii) for 3 months or less	107
(c) Prime mover:	
(i) for more than 6 months but not more than 1 year	286
(ii) for more than 3 months but not more than 6 months	143
(iii) for 3 months or less	71
(d) Tow truck with a GVM of 4.5 tonnes or more but less than 12 tonnes:	
(i) for more than 6 months but not more than 1 year	178
(ii) for more than 3 months but not more than 6 months	89
(iii) for 3 months or less	44
(e) Tow truck with a GVM of 12 tonnes or more:	
(i) for more than 6 months but not more than 1 year	286
(ii) for more than 3 months but not more than 6 months	143
(iii) for 3 months or less	71
(f) Trailer tow truck with a GVM of less than 4.5 tonnes:	
(i) for more than 6 months but not more than 1 year	178
(ii) for more than 3 months but not more than 6 months	89
(iii) for 3 months or less	44
(g) Trailer with a GVM of 4.5 tonnes or more:	
(i) for more than 6 months but not more than 1 year	211
(ii) for more than 3 months but not more than 6 months	105
(iii) for 3 months or less	53
(h) Bus or other vehicle (other than a public passenger vehicle) seating more than 8 adult persons with a GVM of less than 12 tonnes:	
(i) for more than 6 months but not more than 1 year	178

Matter for which fee payable	Fee (\$)
(ii) for more than 3 months but not more than 6 months	89
(iii) for 3 months or less	44
(i) Bus or other vehicle (other than a public passenger vehicle) seating more than 8 adult persons with a GVM of 12 tonnes or more:	
(i) for more than 6 months but not more than 1 year	286
(ii) for more than 3 months but not more than 6 months	143
(iii) for 3 months or less	71
(j) Bus or other vehicle (being a public passenger vehicle) seating more than 8 adult persons with a GVM of less than 12 tonnes:	
(i) for more than 6 months but not more than 1 year	291
(ii) for more than 3 months but not more than 6 months	145
(iii) for 3 months or less	73
(k) Bus or other vehicle (being a public passenger vehicle) seating more than 8 adult persons with a GVM of 12 tonnes or more:	
(i) for more than 6 months but not more than 1 year	507
(ii) for more than 3 months but not more than 6 months	253
(iii) for 3 months or less	127
(l) Taxi (not licensed to operate in a transport district within the meaning of the <i>Transport Administration Act 1988</i>):	
(i) for more than 6 months but not more than 1 year	291
(ii) for more than 3 months but not more than 6 months	145
(iii) for 3 months or less	73
(m) Public passenger vehicle (other than a vehicle referred to elsewhere in this list):	
(i) for more than 6 months but not more than 1 year	291
(ii) for more than 3 months but not more than 6 months	145
(iii) for 3 months or less	73
(n) Any vehicle not referred to elsewhere in this list:	
(i) for more than 6 months but not more than 1 year	65
(ii) for more than 3 months but not more than 6 months	32
(iii) for 3 months or less	16
Note. Under clause 67 (2) (a) of this Regulation, the fees for registration or renewal of registration of a motor vehicle or trailer referred to in paragraphs (a)–(m) include a registration fee component and an inspection fee component for the applicable number of required inspections.	
Part 2 Transfer of registration	
(a) Application made within 14 days after vehicle acquired	32
(b) Application made more than 14 days after vehicle acquired	149
Part 3 Issue of 1 or 2 standard number-plates with same number	
Initial or replacement issue	45

Matter for which fee payable	Fee (\$)
Part 4 Trader's plate	
(a) Issue of a trader's plate for a vehicle other than a motor bike:	
(i) for 12 months	432
(ii) for 1 month	37
(b) Issue of a trader's plate for a motor bike:	
(i) for 12 months	105
(ii) for 1 month	10
Part 5 Initial inspection of registrable vehicle under clause 66, 67 or 81, otherwise than in relation to exhaust emission levels	
(a) Motor lorry (other than an articulated motor lorry or a prime mover) with a GVM of 4.5 tonnes or more but less than 12 tonnes	56
(b) Motor lorry (other than an articulated motor lorry or a prime mover) with a GVM of 12 tonnes or more	221
(c) Articulated motor lorry	363
(d) Prime mover	221
(e) Tow truck with a GVM of less than 12 tonnes	113
(f) Tow truck with a GVM of 12 tonnes or more	221
(g) Tow truck trailer with a GVM of less than 4.5 tonnes	113
(h) Trailer (other than a tow truck trailer) with a GVM of less than 4.5 tonnes	24
(i) Trailer (including a tow truck trailer) with a GVM of 4.5 tonnes or more	146
(j) Bus or other vehicle seating more than 8 adult persons with a GVM of less than 12 tonnes	113
(k) Bus or other vehicle seating more than 8 adult persons with a GVM of 12 tonnes or more	221
(l) Taxi	113
(m) Public passenger vehicle (other than a vehicle referred to elsewhere in this list)	113
(n) Motor bike	24
(o) Any vehicle not referred to elsewhere in this list	41
Part 6 Further inspection of registrable vehicle that has failed earlier inspection under clause 66, 67 or 81	
(a) Where a vehicle may be used while a failure is being rectified	46
(b) Where a vehicle may not be used while a failure is being rectified	92
Part 7 Inspection of registrable vehicle under clause 66 in relation to exhaust emission levels	
Conduct of inspection	53
Part 8 Examiner's authority	
(a) Issue of original authority	180
(b) Issue of duplicate authority	22

Matter for which fee payable	Fee (\$)
Part 9 Proprietor's authority	
(a) Issue of original authority	359
(b) Issue of duplicate authority	22

Schedule 4 Registration charges for chargeable heavy vehicles

Part 1 Annual registration charges

Note 1. This Part reproduces, with some modifications, national uniform legislation. A copy of the *Heavy Vehicle Charges Model Law* on which this Part is based is available at www.pcc.gov.au.

Note 2. This Part divides the registration charges payable for heavy vehicles into regulatory components and road components. Section 25A of the *Heavy Vehicle (Adoption of National Law) Act 2013* provides that an amount equal to any regulatory component that may be prescribed by the national regulations for the purposes of the definition of **road use component** in section 688 (3) of the *Heavy Vehicle National Law (NSW)* is authorised to be paid into the National Heavy Vehicle Regulator Fund until Chapter 2 of that Law comes into force in New South Wales. Clause 69A of the *Heavy Vehicle (General) National Regulation (NSW)* prescribes the regulatory component as the regulatory component of the charges paid for the registration of a heavy vehicle.

1 Annual registration charges for chargeable heavy vehicles (cf 2007 reg cl 76C)

- (1) For the purposes of clause 2 of Schedule 2 to the Act, the amount payable as the annual registration charge for a chargeable heavy vehicle is to be calculated in accordance with the provisions of this Part.
- (2) A heavy vehicle must be registered as an individual vehicle or a towing unit in a category under this Part.

2 Amount of annual registration charge commencing with 2017–2018 financial year

(cf 2007 reg Sch 4 cl 13)

- (1) The annual registration charge for a chargeable heavy vehicle that is registered, or the registration of which is renewed, during the 2017–2018 financial year is:
 - (a) if the vehicle is a truck or prime mover—the sum of:
 - (i) the road component of the charge, being the relevant amount (having regard to the number of axles of the vehicle) set out in Column 2, 3, 4 or 5 of Table 1.1 to this clause opposite the type of truck or prime mover concerned as specified in Column 1 of that Table, and
 - (ii) the regulatory component of the charge, being the relevant amount (having regard to the number of axles of the vehicle) set out in Column 2, 3, 4 or 5 of Table 2.1 to this clause opposite the type of truck or prime mover concerned as specified in Column 1 of that Table, or
 - (b) if the vehicle is a trailer—the sum of:
 - (i) the road component of the charge, being the relevant amount (having regard to the number of axles or axle group of the trailer) set out in Column 2, 3, 4 or 5 of Table 1.2 to this clause opposite the type of trailer concerned as specified in Column 1 of that Table, and
 - (ii) the regulatory component of the charge, being the relevant amount (having regard to the number of axles or axle group of the trailer) set out in Column 2, 3, 4 or 5 of Table 2.2 to this clause opposite the type of trailer concerned as specified in Column 1 of that Table, or
 - (c) if the vehicle is a bus—the sum of:
 - (i) the road component of the charge, being the relevant amount (having regard to the number of axles of the bus) set out in Column 2, 3 or 4 of Table 1.3 to this clause opposite the type of bus concerned as specified in Column 1 of that Table, and
 - (ii) the regulatory component of the charge, being the relevant amount (having regard to the number of axles of the bus) set out in Column 2, 3

or 4 of Table 2.3 to this clause opposite the type of bus concerned as specified in Column 1 of that Table, or

- (d) if the vehicle is a special purpose vehicle—the sum of:
- (i) the road component of the charge, being the amount (if any) specified by, or calculated in accordance with, Column 2 of Table 1.4 to this clause opposite the type of vehicle concerned as specified in Column 1 of that Table, and
 - (ii) the regulatory component of the charge, being the amount (if any) specified by Column 2 of Table 2.4 to this clause opposite the type of vehicle concerned as specified in Column 1 of that Table.
- (2) The annual registration charge for a chargeable heavy vehicle that is registered, or the registration of which is renewed, during the 2017–2018 financial year continues to apply for each subsequent financial year unless another provision of this Schedule provides otherwise.

Table 1—Road component of annual registration charges

Table 1.1—Load carrying vehicles

Column 1	Column 2	Column 3	Column 4	Column 5
Vehicle type	2 axles	3 axles	4 axles	5 or more axles
Trucks				
Truck (type 1)	\$412	\$720	\$720	\$720
Truck (type 2)	\$720	\$817	\$817	\$817
Short combination truck	\$720	\$817	\$1,695	\$1,695
Medium combination truck	\$8,906	\$8,906	\$9,619	\$9,619
Long combination truck	\$12,312	\$12,312	\$12,312	\$12,312
Prime movers				
Short combination prime mover	\$720	\$4,108	\$4,416	\$4,416
Multi-combination prime mover	\$10,421	\$10,421	\$11,463	\$11,463

Table 1.2—Load carrying trailers

Column 1	Column 2	Column 3	Column 4	Column 5
Trailer type	Single axle	Tandem axle group	Tri-axle group	Quad-axle group and above
Pig trailer	\$612 per axle	\$612 per axle	\$612 per axle	\$612 per axle
Dog trailer	\$612 per axle	\$612 per axle	\$612 per axle	\$612 per axle
Semitrailer	\$612 per axle	\$778 per axle	\$553 per axle	\$415 per axle
B-double lead trailer and B-triple lead and middle trailers	\$612 per axle	\$778 per axle	\$553 per axle	\$415 per axle

Column 1	Column 2	Column 3	Column 4	Column 5
Trailer type	Single axle	Tandem axle group	Tri-axle group	Quad-axle group and above
Converter dolly or low loader dolly	No charge	No charge	No charge	No charge

Table 1.3—Buses

Column 1	Column 2	Column 3	Column 4
Bus type	2 axles	3 axles	4 or more axles
Bus (type 1)	\$309	n/a	n/a
Bus (type 2)	\$309	\$2,260	\$2,260
Articulated bus	n/a	\$309	\$309

Table 1.4—Special purpose vehicles

Column 1	Column 2
Vehicle type	Amount or formula for amount
Special purpose vehicle (type P)	No charge
Special purpose vehicle (type T)	\$300
Special purpose vehicle (type O)	An amount in dollars calculated using the formula: $375 + (375 \times \text{Number of axles over 2})$

Table 2—Regulatory component of annual registration charges

Table 2.1—Load carrying vehicles

Column 1	Column 2	Column 3	Column 4	Column 5
Vehicle type	2 axles	3 axles	4 axles	5 or more axles
Trucks				
Truck (type 1)	\$199	\$235	\$250	\$250
Truck (type 2)	\$260	\$331	\$353	\$353
Short combination truck	\$291	\$369	\$353	\$353
Medium combination truck	\$660	\$660	\$714	\$714
Long combination truck	\$913	\$913	\$913	\$913
Prime movers				
Short combination prime mover	\$411	\$411	\$411	\$411
Multi-combination prime mover	\$929	\$929	\$1,022	\$1,022

Table 2.2—Load carrying trailers

Column 1	Column 2	Column 3	Column 4	Column 5
Trailer type	Single axle	Tandem axle group	Tri-axle group	Quad-axle group and above
Pig trailer	\$55 per axle	\$28 per axle	\$18 per axle	\$14 per axle
Dog trailer	\$55 per axle	\$28 per axle	\$18 per axle	\$14 per axle
Semitrailer	\$55 per axle	\$28 per axle	\$18 per axle	\$14 per axle
B-double lead trailer and B-triple lead and middle trailers	\$55 per axle	\$28 per axle	\$18 per axle	\$14 per axle
Converter dolly or low loader dolly	\$55 per axle	\$28 per axle	\$18 per axle	\$14 per axle

Table 2.3—Buses

Column 1	Column 2	Column 3	Column 4
Bus type	2 axles	3 axles	4 or more axles
Bus (type 1)	\$208	n/a	n/a
Bus (type 2)	\$340	\$422	\$422
Articulated bus	n/a	\$337	\$337

Table 2.4—Special purpose vehicles

Column 1	Column 2
Vehicle type	Amount or formula for amount
Special purpose vehicle (type P)	No charge
Special purpose vehicle (type T)	\$205
Special purpose vehicle (type O)	\$205

Part 2 Refunds and exemptions

Division 1 Refunds of registration charges for chargeable heavy vehicles

3 Calculation of refund of registration charges for chargeable heavy vehicles on cancellation of registration (cf 2007 reg cl 76D)

- (1) For the purposes of clause 13 (2) (b) of Schedule 2 to the Act, a refund of a registration charge for a chargeable heavy vehicle is to be calculated in accordance with this clause.
- (2) A refund is to be calculated using the formula:

$$\left(\frac{\text{number of days} \times \text{charge}}{365} \right) - \text{fee}$$
 where:

charge means the registration charge paid under Schedule 2 to the Act.

fee means the unpaid fees payable under the Act or this Regulation (including any unpaid fee for the cancellation of the registration).

number of days means the number of unexpired days of the registration period, from the date on which the Authority cancels the registration of the vehicle.

- (3) If an amount of refund determined in accordance with subclause (2) would comprise an amount that is not a whole number of dollars, the amount of refund is to be adjusted downwards to the next whole number of dollars.

Division 2 Exemptions from registration charges for chargeable heavy vehicles

4 Definition (cf 2007 reg cl 76A)

In this Division:

government-owned vehicle means a vehicle owned by the Crown or by a statutory body representing the Crown.

5 Exemption for eligible pensioners (cf 2007 reg cl 76E)

- (1) A chargeable heavy vehicle that is owned solely by an eligible pensioner, or jointly owned by 2 or more eligible pensioners only, is exempt from registration charges if:
- (a) it is not used in the course of any trade, business or profession or let out for hire, and
 - (b) it is used solely or principally by the pensioner or pensioners, and
 - (c) it is used substantially for social or domestic purposes or for pleasure, and
 - (d) it is a vehicle or a vehicle of a class or description of vehicles approved for the time being by the Authority.
- (2) An eligible pensioner is entitled to an exemption from registration charges in respect of 1 chargeable heavy vehicle only.

6 Exemption for civil defence vehicles (cf 2007 reg cl 76F)

- (1) A chargeable heavy vehicle (other than a government-owned vehicle) that, while on a road or road related area, is used solely for or in connection with civil defence work and is registered in the name of a body controlling that work is exempt from registration charges.
- (2) The Minister may grant an exemption or partial exemption from registration charges in respect of any other chargeable heavy vehicle (other than a government-owned vehicle) that, while on a road or road related area, is used solely for or in connection with civil defence work.
- (3) In this clause:
civil defence work means the work of dealing with an emergency (within the meaning of the *State Emergency and Rescue Management Act 1989*).

7 Exemption for vehicles used for mine rescue work (cf 2007 reg cl 76G)

A chargeable heavy vehicle (other than a government-owned vehicle) specially constructed to carry out mine rescue work for the purposes of the *Coal Industry Act 2001* is exempt from registration charges.

8 Exemption for vehicles with trader's plates (cf 2007 reg cl 76H)

A chargeable heavy vehicle on which a trader's plate is being used in accordance with the Act is exempt from registration charges.

9 Exemption for vehicles exempt from registration (cf 2007 reg cl 76I)

A chargeable heavy vehicle that is exempt from registration is exempt from registration charges.

10 Exemptions granted by Minister (cf 2007 reg cl 76J)

- (1) The Minister may grant an exemption or partial exemption from registration charges in respect of a chargeable heavy vehicle (other than a government-owned vehicle) for which there is no other provision for exemption or partial exemption under this Division if the vehicle:
 - (a) is, in the Minister's opinion, used solely or principally as an ambulance, and
 - (b) is used by or on behalf of a non-profit organisation having as one of its objects a charitable, benevolent, philanthropic or patriotic purpose.
- (2) The Minister may grant an exemption or partial exemption from registration charges in respect of a chargeable heavy vehicle for which there is no other provision for exemption (other than partial exemption) under this Division if the vehicle is registered conditionally under this Regulation.

11 Exemptions relating to certain types of converter dolly and small operators (cf 2007 reg cl 76JA)

- (1) A chargeable heavy vehicle that is a tri-axle converter dolly is exempt from any registration charges for the vehicle.
- (2) A chargeable heavy vehicle that is a tandem axle converter dolly is exempt from registration charges for the vehicle to the extent of an amount that is equivalent to 50 percent of those registration charges.
- (3) A chargeable heavy vehicle that is a non-converter dolly trailer (the **current trailer**) is exempt from registration charges for the trailer to the extent of the exempt amount for that trailer if, at the time of its registration, the registered operator of the current trailer is also the registered operator of:
 - (a) only 1 hauling unit, and 1 (but not more than 4) other non-converter dolly trailers, that are registered at the same time as the current trailer or were previously registered in the current financial year, or
 - (b) only 2 hauling units, and 2 (but not more than 4) other non-converter dolly trailers, that are registered at the same time as the current trailer or were previously registered in the current financial year.
- (4) The **exempt amount** for a current trailer for the purposes of the exemption under subclause (3) is:
 - (a) if the registered operator of the current trailer has previously paid lesser registration charges in the current financial year for 1 or more other non-converter dolly trailers and there was no entitlement to claim the exemption for any of those earlier registered trailers—an amount equivalent to 50 percent of the amount of the lowest registration charges paid for an earlier registered trailer, or
 - (b) in any other case—an amount that is equivalent to 50 percent of the registration charges for the current trailer.
- (5) The exemption provided by subclause (3) only applies in relation to registration charges payable for the registration of a chargeable heavy vehicle for a period of 12 months.
- (6) In this clause:

hauling unit means a rigid vehicle or prime mover.

non-converter dolly trailer means a trailer other than a converter dolly.

tandem axle converter dolly means a trailer with 2 axles and a fifth wheel coupling designed to convert a semitrailer into a dog trailer.

tri-axle converter dolly means a trailer with 3 axles and a fifth wheel coupling designed to convert a semitrailer into a dog trailer.

Part 3 Interpretation

12 Definitions (cf 2007 reg Sch 4 cl 1)

- (1) In this Schedule, a term or expression specified in Column 2 of the following table has, unless otherwise defined in this Schedule, the same meaning as in the legislation specified opposite the term or expression in Column 1:

Column 1	Column 2
Legislation	Term or expression
Schedule 2 to the Act	<i>chargeable heavy vehicle</i> <i>financial year</i> <i>MRC</i> <i>registration charge</i> <i>vehicle</i>
<i>Heavy Vehicle National Law (NSW)</i>	<i>articulated bus</i> <i>axle</i> <i>axle group</i> <i>B-double</i> <i>B-triple</i> <i>bus</i> <i>centre-line</i> <i>converter dolly</i> <i>fifth wheel coupling</i> <i>pig trailer</i> <i>pole-type trailer</i> <i>prime mover</i> <i>quad-axle group</i> <i>semitrailer</i> <i>single axle</i> <i>tandem axle group</i> <i>tri-axle group</i> <i>truck</i> <i>twinsteer axle group</i>
<i>Heavy Vehicle (Mass, Dimension and Loading) National Regulation (NSW)</i>	<i>low loader dolly</i>
<i>Heavy Vehicle (Vehicle Standards) National Regulation (NSW)</i>	<i>dog trailer</i> <i>drawbar</i>

- (2) In this Schedule:
B-double lead trailer means a semitrailer that is nominated for use as the lead trailer in a B-double.
B-triple lead trailer means a semitrailer that is nominated for use as the lead trailer in a B-triple.

B-triple middle trailer means a semitrailer that is nominated for use as the second trailer in a B-triple.

bus (type 1) means a rigid bus that has 2 axles and an MRC not exceeding 12 tonnes.

bus (type 2) means:

- (a) a rigid bus that has 2 axles and an MRC exceeding 12 tonnes, or
- (b) a rigid bus that has 3 or 4 axles.

lead trailer, in a combination, means the trailer that is, or that is to be, attached to the prime mover.

load carrying vehicle means a vehicle designed and constructed to haul or carry goods and wares in addition to any fuel, water, lubricants, tools and any other equipment or accessories necessary for normal operation of the vehicle.

long combination truck means a truck nominated to haul 2 or more trailers.

low loader means a gooseneck semitrailer with a loading deck no more than 1 metre above the ground.

medium combination truck means a truck, other than a short combination truck, nominated to haul one trailer.

multi-combination prime mover means a prime mover nominated to haul 2 or more trailers.

nominated means nominated by the person applying for registration.

short combination prime mover means a prime mover nominated to haul 1 semi trailer.

short combination truck means a truck nominated to haul 1 trailer where, according to the nomination:

- (a) the combination has 6 axles or fewer, and
- (b) the maximum total mass that is legally allowable for the combination is 42.5 tonnes or less.

special purpose vehicle—see clause 15.

special purpose vehicle (type O) means a special purpose vehicle (other than a special purpose vehicle (type P)):

- (a) built, or permanently modified, primarily for use on roads, and
- (b) that has at least 1 axle or axle group loaded in excess of the axle load limits specified in the Table to this definition.

Note. Examples of this kind of vehicle are mobile cranes, fire engines, truck-mounted concrete pumps and boring plants. These kinds of vehicle may also fall within the definition of ***special purpose vehicle (type T)*** if they have no axle or axle group loaded in excess of the axle load limits specified in the Table to this definition.

Table—Axle load limits

Column 1	Column 2	Column 3
Item no	Type of axle or axle group	Axle load limit (tonnes)
1	Single axles:	
	(a) 2 tyres	6.0
	(b) 2 wide profile tyres (375mm to 450mm)	6.7
	(c) 2 wide profile tyres (over 450mm),	7.0
	(d) 4 or more tyres (on pig trailer)	8.5
	(e) 4 or more tyres (on other vehicles)	9.0

Column 1	Column 2	Column 3
Item no	Type of axle or axle group	Axle load limit (tonnes)
2	Twinsteer axle groups:	
	(a) non-load sharing suspensions	10.0
	(b) load sharing suspensions	11.0
3	Tandem axle groups:	
	(a) 4 tyres	11.0
	(b) 4 wide profile tyres (375mm to 450mm)	13.3
	(c) 4 wide profile tyres (over 450mm)	14.0
	(d) 6 tyres	13.0
	(e) 8 or more tyres (on pig trailers)	15.0
	(f) 8 or more tyres (on other vehicles)	16.5
4	Tri-axle groups:	
	(a) 6, 8 or 10 tyres	15.0
	(b) 6 wide profile tyres (375mm or over) on pig trailers	18.0
	(c) 6 wide profile tyres (375mm or over) on other vehicles	20.0
	(d) 12 or more tyres (on pig trailers)	18.0
	(e) 12 or more tyres (on other vehicles)	20.0

special purpose vehicle (type P) means a special purpose vehicle built, or permanently modified, primarily for:

- (a) off-road use, or
- (b) use on a road related area, or
- (c) use on an area of road that is under construction or repair.

Note. Examples of this kind of vehicle are agricultural tractors, self-propelled agricultural harvesters, bulldozers, backhoes, graders and front-end loaders.

special purpose vehicle (type T) means a special purpose vehicle (other than a special purpose vehicle (type P)):

- (a) built, or permanently modified, primarily for use on roads, and
- (b) that has no axle or axle group loaded in excess of the axle load limits specified in the Table to the definition of **special purpose vehicle (type O)** in this subclause.

Note. Examples of this kind of vehicle are mobile cranes, fire engines, truck-mounted concrete pumps and boring plants. These kinds of vehicle may also fall within the definition of **special purpose vehicle (type O)** if they have at least 1 axle or axle group loaded in excess of the axle load limits specified in the Table to that definition.

truck (type I) means a truck that has:

- (a) 2 axles and an MRC not exceeding 12 tonnes, or
- (b) 3 axles and an MRC not exceeding 16.5 tonnes, or
- (c) 4 or more axles and an MRC not exceeding 20 tonnes.

truck (type 2) means a truck that has:

- (a) 2 axles and an MRC exceeding 12 tonnes, or
- (b) 3 axles and an MRC exceeding 16.5 tonnes, or
- (c) 4 or more axles and an MRC exceeding 20 tonnes.

13 Close-spaced axles (cf 2007 reg Sch 4 cl 2)

- (1) To avoid doubt, for the purposes of this Schedule:
 - (a) 3 axles not more than 2 metres apart are to be regarded as 2 axles, and
 - (b) 4 axles not more than 3.2 metres apart are to be regarded as 3 axles.

Note. For the purposes of this Schedule, 2 axles less than 1 metre apart are to be regarded as a single axle: see the definition, applied by clause 12 (1), of **single axle** in the *Heavy Vehicle National Law (NSW)*.

- (2) A reference to a distance in subclause (1) is a reference to the horizontal distance between the centre-lines of the outermost axles.

14 Determination of number of trailers (cf 2007 reg Sch 4 cl 3)

For the purposes of determining the number of trailers that a prime mover or truck is nominated to haul:

- (a) a converter dolly and a semi trailer when used together are to be regarded as 1 trailer, and
- (b) a low loader dolly and a low loader when used together are to be regarded as 1 trailer.

Note. Nothing in this clause affects the requirement under another Part of this Schedule that a separate annual registration fee be paid for each converter dolly or low loader dolly and for each semitrailer.

15 Special purpose vehicle (cf 2007 reg Sch 4 cl 4)

- (1) In this Schedule, **special purpose vehicle** means:
 - (a) a vehicle (other than a caravan, a mobile home, a mobile library, a mobile workshop, a mobile laboratory or a mobile billboard) where the primary purpose for which it was built, or permanently modified, was not the carriage of goods or passengers, or
 - (b) any of the following vehicles:
 - (i) a forklift,
 - (ii) a straddle carrier,
 - (iii) a mobile cherry picker,
 - (iv) a mobile crane.
- (2) The term **goods** in subclause (1) (a) does not include fuel, water, lubricants, tools and any other equipment or accessories necessary for the normal operation of the vehicle.

16 Chargeable heavy vehicles in 2 or more categories (cf 2007 reg Sch 4 cl 5)

If a chargeable heavy vehicle falls within 2 or more categories or types of vehicle that are relevant for the purposes of determining a registration charge under this Schedule, the charge for the vehicle is the higher or highest of the charges that could apply to the vehicle.

Schedule 5 Amendment of statutory rules under Road Transport Act 2013 No 18

5.1 Road Rules 2014

[1] Rule 214–1 NSW rule: interpretation

Omit the definitions of *dipping device*, *headlight* and *parking light*.

Insert in alphabetical order:

dipping device has the same meaning as in rule 79 of the Light Vehicle Standards Rules.

headlight means a headlight of the kind referred to in the Light Vehicle Standards Rules.

parking light means a parking light of the kind referred to in the Light Vehicle Standards Rules.

[2] Rule 218–1 NSW rule: using lights on vehicles generally

Omit “clause 86 (6) of Schedule 2 to the *Road Transport (Vehicle Registration) Regulation 2007*” from rule 218–1 (d).

Insert instead “rule 73 (6) of the Light Vehicle Standards Rules”.

[3] Rule 218–1 (e)

Omit “clause 124 (4) of Schedule 2 to the *Road Transport (Vehicle Registration) Regulation 2007*”.

Insert instead “rule 114 (4) of the Light Vehicle Standards Rules”.

[4] Rule 218–1 (f)

Omit “clause 125 of Schedule 2 to the *Road Transport (Vehicle Registration) Regulation 2007*”.

Insert instead “rule 114A of the Light Vehicle Standards Rules”.

[5] Rule 221–1 NSW rule: using crimson flashing warning lights on certain local council vehicles

Omit “clause 124 (4)–(9) of Schedule 2 to the *Road Transport (Vehicle Registration) Regulation 2007*” from rule 221–1 (1).

Insert instead “rule 114 (4)–(9) of the Light Vehicle Standards Rules”.

[6] Rule 221–2 NSW rule: using flashing warning lights on street vending vehicles

Omit “clause 126 of Schedule 2 to the *Road Transport (Vehicle Registration) Regulation 2007*” from the definition of *prescribed flashing warning light* in rule 221–2 (3).

Insert instead “rule 114B of the Light Vehicle Standards Rules”.

[7] Rule 221–2 (3), definition of “street vending vehicle”

Omit “*Road Transport (Vehicle Registration) Regulation 2007*”.

Insert instead “Light Vehicle Standards Rules”.

[8] Rule 222–1 NSW rule: using four-way flashers on school buses

Omit “clause 125 (1) of Schedule 2 to the *Road Transport (Vehicle Registration) Regulation 2007*” from paragraph (a) of the definition of *four-way flasher* in rule 222–1 (4).

Insert instead “rule 114A (1) of the Light Vehicle Standards Rules”.

[9] Rule 222–1 (4), paragraph (b) of definition of “four-way flasher”

Omit “clause 113 (4) of that Schedule”.

Insert instead “rule 100 (4) of the Light Vehicle Standards Rules”.

[10] Rule 266 Wearing of seatbelts by passengers under 16 years old

Omit “clause 13 of the *Road Transport (Vehicle Registration) Regulation 2007*” from rule 266 (5A–1) (a) (iii).

Insert instead “clause 13 of the *Road Transport (Vehicle Registration) Regulation 2017*”.

[11] Dictionary

Omit the definitions of *applicable vehicle standards law* and *corresponding heavy vehicle standard*.

Insert in alphabetical order:

applicable vehicle standards law has the same meaning as in the *Road Transport (General) Regulation 2013*.

corresponding heavy vehicle standard has the same meaning as in the *Road Transport (General) Regulation 2013*.

Light Vehicle Standards Rules has the same meaning as in the *Road Transport (Vehicle Registration) Regulation 2017*.

[12] Dictionary, definition of “approved seatbelt”

Omit “*Road Transport (Vehicle Registration) Regulation 2007*”.

Insert instead “*Road Transport (Vehicle Registration) Regulation 2017*”.

[13] Dictionary, definition of “mechanical signalling device”

Omit “Division 11 of Part 5, and clause 129, of Schedule 2 to the *Road Transport (Vehicle Registration) Regulation 2007*”.

Insert instead “Division 12 of Part 7, and rule 117, of the Light Vehicle Standards Rules”.

[14] Dictionary, paragraph (d) of definition of “oversize vehicle”

Omit “*Road Transport (Vehicle Registration) Regulation 2007*”.

Insert instead “*Road Transport (Vehicle Registration) Regulation 2017*”.

[15] Dictionary, definition of “station wagon”

Omit “*Road Transport (Vehicle Registration) Regulation 2007*”.

Insert instead “*Road Transport (Vehicle Registration) Regulation 2017*”.

[16] Dictionary, definition of “third edition ADR”

Omit “*Road Transport (Vehicle Registration) Regulation 2007*”.

Insert instead “Light Vehicle Standards Rules”.

[17] Dictionary, definition of “tow truck”

Omit “*Road Transport (Vehicle Registration) Regulation 2007*”.

Insert instead “*Road Transport (Vehicle Registration) Regulation 2017*”.

5.2 Road Transport (General) Regulation 2013

[1] Clause 3 Definitions

Omit the definitions of *applicable vehicle standards law* and *motor registry* from clause 3 (1).

Insert in alphabetical order:

applicable vehicle standards law means clause 25 of the *Road Transport (Vehicle Registration) Regulation 2017* and:

- (a) in the case of a light vehicle—the Light Vehicle Standards Rules, or
- (b) in the case of a heavy vehicle within the meaning of the *Heavy Vehicle National Law (NSW)*—the heavy vehicle standards within the meaning of that Law.

Note. See the *Heavy Vehicle (Vehicle Standards) National Regulation (NSW)*.

Light Vehicle Standards Rules has the same meaning as in the *Road Transport (Vehicle Registration) Regulation 2017*.

registry has the same meaning as in the *Road Transport (Vehicle Registration) Regulation 2017*.

[2] Clause 3 (1), definition of “corresponding heavy vehicle standard”

Omit “Schedule 2 to the *Road Transport (Vehicle Registration) Regulation 2007*”.

Insert instead “the Light Vehicle Standards Rules”.

[3] Clause 3 (1), definition of “station wagon”

Omit “*Road Transport (Vehicle Registration) Regulation 2007*”.

Insert instead “*Road Transport (Vehicle Registration) Regulation 2017*”.

[4] Clause 3 (1), definition of “third edition ADR”

Omit “*Road Transport (Vehicle Registration) Regulation 2007*”.

Insert instead “Light Vehicle Standards Rules”.

[5] Clauses 6 (7), 7 (4), 107 (2) (c) and 144A (1) (g)

Omit “motor registry” wherever occurring. Insert instead “registry”.

[6] Clause 7 Service of notices on registered operators and delivery of things to Authority under vehicle registration law

Omit “*Road Transport (Vehicle Registration) Regulation 2007*” wherever occurring.

Insert instead “*Road Transport (Vehicle Registration) Regulation 2017*”.

[7] Clause 16 Use of crimson flashing warning lights on certain council vehicles

Omit “clause 124 (4)–(9) of Schedule 2 to the *Road Transport (Vehicle Registration) Regulation 2007*” from clause 16 (1).

Insert instead “rule 114 (4)–(9) of the Light Vehicle Standards Rules”.

[8] Clause 50L Projection of loading or equipment of vehicles

Omit “*Road Transport (Vehicle Registration) Regulation 2007*” from clause 50L (1) (a) (v).

Insert instead “*Road Transport (Vehicle Registration) Regulation 2017*”.

- [9] Clause 50L (2) (a)**
Omit “Schedule 2 to the *Road Transport (Vehicle Registration) Regulation 2007*”.
Insert instead “the Light Vehicle Standards Rules”.
- [10] Clause 125 Definitions**
Omit “*Road Transport (Vehicle Registration) Regulation 2007*” wherever occurring.
Insert instead “*Road Transport (Vehicle Registration) Regulation 2017*”.
- [11] Clause 127 Vehicle registration decisions**
Omit “*Road Transport (Vehicle Registration) Regulation 2007*” wherever occurring in clause 127 (a) and (b).
Insert instead “*Road Transport (Vehicle Registration) Regulation 2017*”.
- [12] Clause 127 (c)**
Omit “Part 5A of the *Road Transport (Vehicle Registration) Regulation 2007*”.
Insert instead “Part 6 of the *Road Transport (Vehicle Registration) Regulation 2017*”.
- [13] Clause 127 (c) (iii)**
Omit “clause 76AK”. Insert instead “clause 92”.
- [14] Clause 127 (d)**
Omit the paragraph.
- [15] Clause 135 Certain decisions stayed pending appeal**
Omit clause 135 (1) (f).
- [16] Clause 135 (1) (g)**
Omit “clause 41 (2), (2A) or (2B) of the *Road Transport (Vehicle Registration) Regulation 2007*”.
Insert instead “clause 45 (2), (3) or (4) of the *Road Transport (Vehicle Registration) Regulation 2017*”.
- [17] Clause 135A Certain decisions stayed only in exceptional circumstances**
Omit “clause 41A of the *Road Transport (Vehicle Registration) Regulation 2007*” from clause 135A (2) (a).
Insert instead “clause 46 of the *Road Transport (Vehicle Registration) Regulation 2017*”.
- [18] Clause 138 Document that may be used in examiner’s and proprietor’s authorities appeals**
Omit “clause 63 of the *Road Transport (Vehicle Registration) Regulation 2007*”.
Insert instead “clause 73 of the *Road Transport (Vehicle Registration) Regulation 2017*”.
- [19] Clause 140 Delegation of Authority’s licensing and registration functions**
Omit “*Road Transport (Vehicle Registration) Regulation 2007*” from clause 140 (2) (b).
Insert instead “*Road Transport (Vehicle Registration) Regulation 2017*”.

[20] Clause 144A Number-plate confiscation notices

Omit clause 144A (2). Insert instead:

- (2) In this clause, *VIN* has the same meaning as in the *Road Transport (Vehicle Registration) Regulation 2017*.

[21] Schedule 5 Penalty notice offences

Omit the matter relating to *Road Transport (Vehicle Registration) Regulation 2007*.

Insert instead:

Road Transport (Vehicle Registration) Regulation 2017

Column 1	Column 2	Column 3
Provision	Authorised officer	Penalty
Clause 23 (4); Clause 29 (1); Clause 30 (1); Clause 31; Clause 36 (8); Clause 37 (1); Clause 37 (2); Clause 37 (3); Clause 37 (4); Clause 37 (6); Clause 37 (7); Clause 39 (1); Clause 42 (3); Clause 43 (4); Clause 47 (5); Clause 52 (3); Clause 53; Clause 54; Clause 55; Clause 56 (2); Clause 56 (3); Clause 60 (1) except in relation to a matter provided for elsewhere in this Table; Clause 60 (2); Clause 60 (4); Clause 60 (5); Clause 66 (4); Clause 68 (8); Clause 68 (9); Clause 69 (4); Clause 77 (1); Clause 77 (2); Clause 77 (3); Clause 78; Clause 80 (7); Clause 128 (1); Clause 129 (2); Clause 130 (1); Clause 130 (3)	Class 1, 2	Level 2
Clause 34 (1) and (2)	Class 1	Level 15
Clause 60 (1) (a), in the case of a class A motor vehicle	Class 1, 2	Level 6
Clause 60 (1) (a), in the case of a class B motor vehicle	Class 1, 2	Level 8
Clause 60 (1) (a), in the case of a class C motor vehicle	Class 1, 2	Level 8
Clause 60 (1) (b) (i) in the case of a light vehicle that does not comply with any of the following provisions of the Light Vehicle Standards Rules:		
(a) rule 25C (b), vehicle cause danger or unreasonable annoyance	Class 1, 2	Level 3
(b) rule 26, defective steering	Class 1, 2	Level 5
(c) rule 29 (3), motor vehicle manufactured on or after 1 January 2003 (except if the model of the vehicle is a model of a kind manufactured before 1 January 2003) that has a GVM of not more than 3.5 tonnes and that is fitted with a vehicle frontal protection system (such as bullbar, roobar or nudge bar) failing to comply with AS 4876.1–2002 <i>Motor vehicle frontal protection systems—Road user protection</i> because of:	Class 1, 2	Level 3
(i) incorrect method of mounting vehicle frontal protection system, or		
(ii) exposed edges, or		
(iii) unacceptable shape of material or unacceptable profile of vehicle frontal protection system, or		
(iv) use of non-standard or non-approved vehicle frontal protection system		

Road Transport (Vehicle Registration) Regulation 2017

Column 1	Column 2	Column 3
Provision	Authorised officer	Penalty
(d) rule 29 (3), motor vehicle manufactured on or after 1 January 2003 (except if the model of the vehicle is a model of a kind manufactured before 1 January 2003) that has a GVM of not more than 3.5 tonnes and that is fitted with a vehicle frontal protection system (such as bullbar, roobar or nudge bar) failing to comply with AS 4876.1–2002 <i>Motor vehicle frontal protection systems—Road user protection</i> because of dangerous protrusions (such as fishing rod holders, aerials, winches and brackets for the mounting of spot lamps) fitted to vehicle frontal protection system	Class 1, 2	Level 5
(e) rule 29A, oil and grease leaks	Class 1, 2	Level 3
(f) rule 31, defective seating	Class 1, 2	Level 5
(g) rule 31A, seatbelt removed or defective	Class 1, 2	Level 5
(h) rule 31A, motor vehicle not fitted or equipped with seatbelts or seatbelt anchorages	Class 1, 2	Level 5
(i) rules 119–121 or 123–128, defective brakes	Class 1, 2	Level 5
(j) rule 122, defective brake other than a defective emergency brake	Class 1, 2	Level 5
(k) rules 130, 134, 137 or 139–141, undue emission, inefficient silencer or excessive noise	Class 1, 2	Level 3
(l) rule 143 or 144, defective LPG or natural gas equipment or labelling	Class 1, 2	Level 3
Clause 60 (1) (b) (ii)	Class 1, 2	Level 3
Clause 64 (1)	Class 1, 2	Level 8
Clause 68 (10); Clause 69 (6)	Class 1, 2	Level 4
Clause 80 (4)	Class 1, 2	Level 5
Clause 81 (6), Clause 128 (2), in the case of a minor defect notice	Class 1, 2	Level 5
Clause 84 (1)	Class 1, 2	Level 9
Clause 85 (2); Clause 85 (5); Clause 93 (1); Clause 93 (2); Clause 93 (3)	Class 2	Level 8
Clause 85 (6)	Class 2	Level 5
Clause 90 (5); Clause 94 (2); Clause 94 (3); Clause 95 (1); Clause 95 (2)	Class 2	Level 9
Clause 109 (2); Clause 112 (1); Clause 112 (2); Clause 113; Clause 121	Class 1, 2	Level 5
Clause 116	Class 2	Level 8
Clause 119	Class 2	Level 12
Clause 128 (2), in the case of a major defect notice	Class 1, 2	Level 6
Clause 128 (3); Clause 128 (5)	Class 1, 2	Level 8
Clause 129 (1) (a), Clause 129 (3), in the case of a class A motor vehicle	Class 1, 2	Level 6
Clause 129 (1) (b), Clause 129 (1) (c), Clause 129 (4), in the case of a class A motor vehicle	Class 1, 2	Level 2
Clause 129 (1), Clause 129 (3), Clause 129 (4), in the case of a class B motor vehicle or class C motor vehicle	Class 1, 2	Level 8

Dictionary

Note. The Act and the *Interpretation Act 1987* contain definitions and other provisions that affect the interpretation and application of this Regulation.

applicable fee, in relation to a matter, means a fee set, fixed or prescribed by or under this Regulation in relation to the matter.

applicable vehicle standards—see clause 59.

articulated vehicle means a motor vehicle having at its rear a portion, on wheels, which is pivoted to, and a part of which (not being a pole, drawbar or similar device or an accessory of the motor vehicle) is superimposed upon, the forward portion of the vehicle.

authorised examiner means a person authorised to carry out any function under clause 68.

authorised inspection station means premises that a person is authorised to use under clause 69.

authorised person means a person authorised by the Authority to be an authorised person for the purposes of this Regulation.

authorised proprietor means a person authorised under clause 69.

Authority standard compliance specifications means any specifications that the Authority, by order published in the Gazette, has declared to be specifications the compliance with which will be taken to be compliance with the applicable vehicle standards for the purposes of clause 64 or 85.

auxiliary number-plate means a number-plate referred to in clause 22.

axle means one or more shafts positioned in a line across a vehicle, on which one or more wheels intended to support the vehicle turn.

axle group means a single axle group, tandem axle group, twinsteer axle group, tri-axle group or quad-axle group.

B-double means a combination consisting of a prime mover towing 2 semi-trailers.

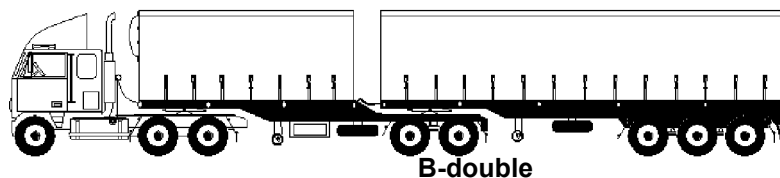

brake means a device for retarding or controlling the rotation of the wheels of a vehicle and for bringing the vehicle to a stop.

bus means a motor vehicle built mainly to carry people that seats over 9 adults (including the driver).

car means a motor vehicle built mainly to carry people that:

- seats not over 9 adults (including the driver), and
- has a body commonly known as a sedan, station wagon, coupe, convertible, or roadster, and
- has 3 or more wheels.

car derivative means a motor vehicle:

- that is of the kind known as a utility, station wagon or panel van, and
- that is of the same make as a factory produced car, and
- in which that part of the body form that is forward of the windscreen and the greater part of the mechanical equipment are the same or substantially the same as in a factory produced car.

certificate of approved operations means a certificate issued in respect of a registrable vehicle in accordance with clause 63.

certificate of registration means a certificate issued in respect of a registrable vehicle under Division 4 of Part 2.

combination means a group of vehicles consisting of a motor vehicle connected to 1 or more vehicles.

converter dolly means a trailer with 1 axle group or single axle and a fifth wheel coupling, designed to convert a semi-trailer into a dog trailer.

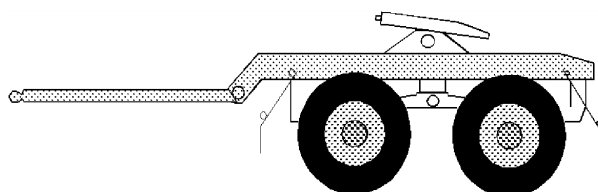

Converter dolly

corporation means a corporation recognised under the laws of Australia, including a foreign corporation and a body incorporated by or under statute.

dog trailer means a trailer (including a trailer consisting of a semi-trailer and converter dolly) with:

- (a) 1 axle group or single axle at the front that is steered by connection to the towing vehicle by a drawbar, and
- (b) 1 axle group or single axle at the rear.

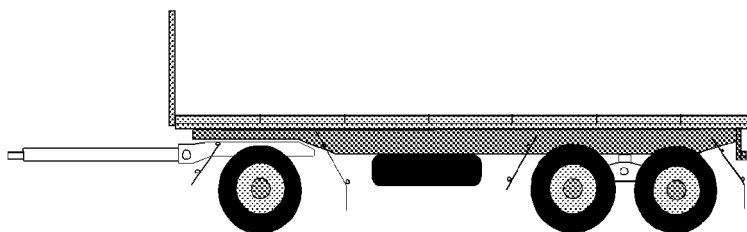

Dog trailer

drawbar means a part of a trailer (other than a semi-trailer) that connects the trailer body to a coupling for towing purposes.

drive includes be in control of.

driver, of a vehicle, means the person driving the vehicle.

duty legislation means the provisions of the *Duties Act 1997* relating to the payment of duty on the registration or transfer of registration of a motor vehicle, trailer or other registrable vehicle.

effective range means the distance at which a light, when lighted, will illuminate and render easily discernible under normal atmospheric conditions between sunset and sunrise any person dressed in dark clothing, or any substantial dark object, in front of the vehicle to which the light is affixed.

eligible pensioner has the same meaning as it has in the *Motor Vehicles Taxation Act 1988*.

examiner's authority means an authority in force under clause 68.

fifth wheel coupling means a device, other than the upper rotating element and the kingpin (which are parts of a semi-trailer), used with a prime mover, semi-trailer or a converter dolly to permit quick coupling and uncoupling and to provide for articulation.

forfeited vehicle means a registrable vehicle that is the subject of a forfeiture order of the Local Court made under section 79 of the Act.

identification plate means a plate authorised to be placed on a vehicle, or taken to have been placed on a vehicle, under the *Motor Vehicle Standards Act 1989* of the Commonwealth.

implement means a motor vehicle which comprises an excavator, road grader, road roller, bulldozer, forklift truck or other machinery or apparatus and is not constructed on a chassis of a type normally used in the construction of a motor lorry.

inspect, in relation to a registrable vehicle, includes observe the vehicle's performance, with or without the use of instrumentation.

inspection report, in relation to a registrable vehicle, means an inspection report issued under clause 59 for the vehicle.

jurisdiction means a State, the Australian Capital Territory or the Northern Territory, as the case requires.

left, in relation to a vehicle, means to the left of the centre of the vehicle when viewed by a person in the vehicle and facing towards the front of the vehicle.

light vehicle means a registrable vehicle that is not a heavy vehicle.

Light Vehicle Standards Rules means the rules set out in Schedule 2.

major defect notice—see clause 80 (1) (a).

minor defect notice—see clause 80 (1) (b).

motor bike means a motor vehicle with 2 wheels, and includes a 2 wheeled motor vehicle with a sidecar attached to it that is supported by a third wheel.

motor dealer, in relation to a vehicle, means the holder of a motor dealer's licence under the *Motor Dealers and Repairers Act 2013*.

motor lorry means any motor vehicle (whether or not in combination with any trailer) that is constructed principally for the conveyance of goods or merchandise or for the conveyance of any kind of materials used in any trade, business or industry, or for use in any work whatsoever other than the conveyance of persons, but does not include a motor bike or a tractor.

motor trike means a motor vehicle with 3 wheels, but does not include a 2 wheeled motor vehicle with a sidecar attached to it that is supported by a third wheel.

motor vehicle combination means a hauling unit with one or more trailers attached.

motor vehicle recycler has the same meaning as in Part 4.5 of the Act.

nominated configuration means the configuration in which a registrable vehicle will operate for the registration period, as nominated by the registered operator.

number includes a letter of the alphabet.

number-plate means a number-plate issued under this Regulation.

operations plate means a plate installed on a registrable vehicle in accordance with clause 63 (2).

owner, in relation to a vehicle, means:

- (a) a person in whose name the vehicle is registered under a Commonwealth, State or Territory Act, or
- (b) a person who, according to the vehicle registration authority's records, has acquired the vehicle from the person in whose name the vehicle is registered under the relevant Act, or
- (c) if the vehicle is not registered—a person to whom a mark, plate or permit has been issued to allow the vehicle to be used, or
- (d) a person who is entitled to the possession of the vehicle.

pole-type trailer means a trailer that:

- (a) is attached to a towing vehicle by means of a pole or an attachment fitted to the pole, and
- (b) is ordinarily used for transporting loads, such as logs, pipes, structural members or other long objects, that are generally capable of supporting themselves like beams between supports.

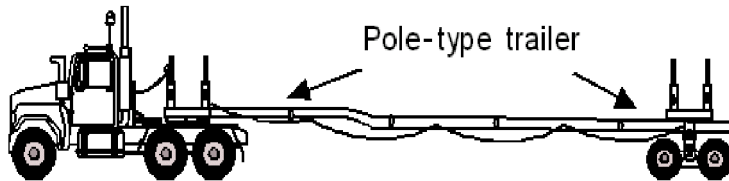

Pole-type trailer

prime mover means a motor vehicle built to tow a semi-trailer.

proprietor's authority means an authority in force under clause 69.

public passenger vehicle means a registrable vehicle that is constructed principally for the conveyance of passengers and that is:

- (a) used for conveying passengers for hire or reward, or
- (b) equipped to seat more than 8 adults, including the driver, and is used for conveying passengers in the course of trade or business.

public utility service vehicle means a vehicle being used by a public authority or statutory body, or an authorised distributor under the *Electricity Network Assets (Authorised Transactions) Act 2015*, in connection with the supply of water, gas, electricity or the like or to remove garbage.

quad-axle group means a group of 4 axles, in which the horizontal distance between the centre lines of the outermost axles is more than 3.2 metres but not more than 4.9 metres.

rear overhang, of a vehicle, means the distance between the rear overhang line and the rear of the vehicle.

rear overhang line means:

- (a) if there is a single axle at the rear of the vehicle—the centre line of the axle, or
- (b) if there is an axle group at the rear of the vehicle—the centre of the axle group, decided without regard to the presence of any steerable axle unless all axles in the group are steerable.

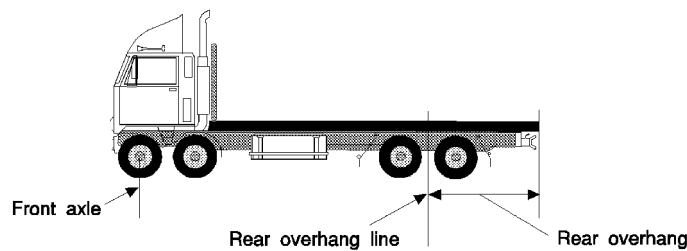

Rear overhang and rear overhang line—motor vehicle

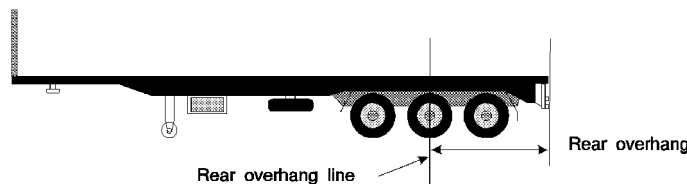

Rear overhang and rear overhang line—semi-trailer

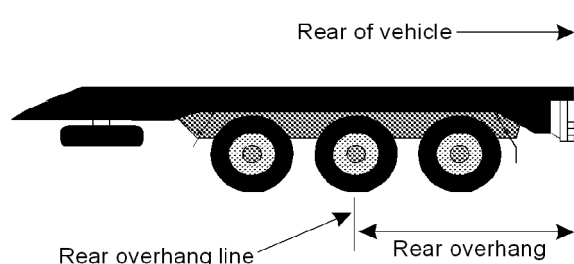

Rear overhang and rear overhang line—vehicle with tri-axle group at rear

Register means the NSW registrable vehicles register.

registry means a place at which registration of a registrable vehicle can be effected by or on behalf of the Authority.

registration label means a registration label issued under Division 4 of Part 2.

registration number means a number referred to in clause 20 (1).

relevant registration charge for a vehicle means:

- (a) in relation to a heavy vehicle—the amount payable as a registration charge under Schedule 2 to the Act, or
- (b) in relation to a light vehicle—the amount payable as motor vehicle tax under the *Motor Vehicles Taxation Act 1988*.

right, in relation to a vehicle, means to the right of the centre of the vehicle when viewed by a person in the vehicle and facing towards the front of the vehicle.

safety risk means danger to a person, to property or to the environment.

seasonal vehicle means a registrable vehicle used during part of the year only and of a type approved by the Authority for seasonal use.

seatbelt means a belt or similar device that is fitted to a motor vehicle and designed to restrain or limit the movement of a person who is seated in the vehicle and wearing the belt or device if the vehicle suddenly accelerates or decelerates.

seatbelt anchorage means the part of a motor vehicle which is designed to secure a seatbelt to the motor vehicle.

security interest means an interest in, or a power over, goods that secures payment of a debt or other pecuniary obligation or the performance of any other obligation and includes any interest in, or power over, goods of a lessor, owner or other supplier of goods, but does not include a possessory lien or pledge.

semi-trailer means a trailer (including a pole-type trailer) that has:

- (a) one axle group or single axle towards the rear, and
- (b) a means of attachment to a prime mover that would result in some of the load being imposed on the prime mover.

service brake means the brake normally used to decelerate a vehicle.

sidecar means any car, box or other receptacle attached to the side of a motor bike and for the carriage of which a third wheel is provided.

side marker light means a light which, when lighted, is visible from the side of the vehicle on which it is affixed.

single axle means an axle not forming part of an axle group.

single axle group means a group of 2 or more axles in which the horizontal distance between the centre lines of the outermost axles is less than 1 metre.

special number-plate means a number-plate that has a special design, content or format designated by the Authority from time to time as constituting a special number-plate for the purposes of this Regulation.

spring brake means a brake using one or more springs to store the energy required to operate the brake.

standard number-plate means a number-plate that is not a special number-plate.

station wagon means a motor vehicle:

- (a) in which any part of the body form that is adjacent to and forward of the front seat or seats, and the greater part of the mechanical equipment, are the same or substantially the same as in a car of the same make, and
- (b) in which the body is carried without significant reduction in height from the front seat or seats to, or substantially towards, the rear of the vehicle, and
- (c) that has an entrance at the rear suitable for the loading and unloading of goods, and
- (d) that is manufactured with a rear seat or seats which can be folded or removed readily to provide additional floor space for the carriage of goods, and
- (e) that, when the seat or seats immediately to the rear of the front seat or seats are in position for the accommodation of persons, has a substantial space for the carriage of goods in proportion to the overall size of the interior of the vehicle.

steerable axle means an axle the wheels of which are connected to a steering mechanism for the vehicle.

street rod vehicle means a vehicle that has been modified for safe road use and that:

- (a) has a body and frame that were built before 1949, or
- (b) is a replica of a vehicle the body and frame of which were built before 1949.

tandem axle group means a group of at least 2 axles in which the horizontal distance between the centre lines of the outermost axles is at least 1 metre, but not more than 2 metres.

taxi means a motor vehicle (other than a bus) that plies or stands in a road or road related area for hire for the conveyance of passengers.

the Act means the *Road Transport Act 2013*.

third party insurance legislation means the provisions of the *Motor Accidents Compensation Act 1999* relating to:

- (a) compensation in respect of third parties who are injured or killed by the use of motor vehicles or trailers, or
- (b) payment of contributions towards compensation of that kind.

tow truck means a motor lorry, operated or proposed to be operated by a tow truck operator, that is used for towing broken down or damaged vehicles and which comprises or has permanently affixed to it a crane or similar apparatus for lifting a vehicle partially clear of the ground and is equipped to maintain it in such a position while towing it and includes a tow truck within the meaning of the *Tow Truck Industry Act 1998*.

tow truck operator has the same meaning as it has in the *Tow Truck Industry Act 1998*.

tractor means any motor vehicle constructed principally for the purpose of supplying motive power for machinery or of hauling any vehicle, but which is not capable of carrying any loading (other than tools, spare parts, fuel, water, oil, or other accessories necessary for use in connection with the vehicle) or any part of the weight of a vehicle being drawn or its loading.

trader means a person who is entitled to hold a trader's plate.

tri-axle group means a group of at least 3 axles, in which the horizontal distance between the centre lines of the outermost axles is more than 2 metres, but not more than 3.2 metres.

turntable means a bearing that is built to carry vertical and horizontal loads, but does not allow quick separation of its upper and lower rotating elements, and that is used to connect and allow articulation between:

- (a) a prime mover and a semi-trailer, or

- (b) the steering axle or axle group of a dog trailer and the body of the trailer, or
- (c) a fifth wheel coupling and the vehicle to which it is mounted.

twinsteer axle group means a group of 2 axles:

- (a) with single tyres, and
- (b) fitted to a motor vehicle, and
- (c) connected to the same steering mechanism, and
- (d) the horizontal distance between the centre lines of which is at least 1 metre, but not more than 2 metres.

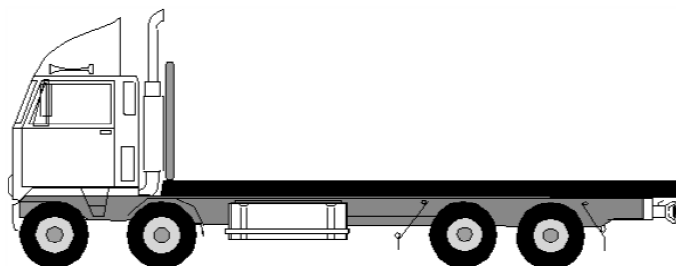

Twinsteer axle group on a motor vehicle

vehicle defect notice means:

- (a) a vehicle defect notice issued under the Act, or
Note. See section 76 (4) (a) of the Act.
- (b) a vehicle defect notice issued under the *Heavy Vehicle National Law (NSW)*.
Note. See Division 6 of Part 9.3 of that Law.

vehicle inspection station means a place operated by the Authority for the purpose of determining whether registrable vehicles comply with the applicable vehicle standards for the vehicles.

vehicle number-plate means a number-plate other than an auxiliary number-plate.

vehicle registration authority, in relation to a vehicle, means:

- (a) the authority that last registered the vehicle, or
- (b) if the vehicle has never been registered—the authority responsible for registering vehicles in the jurisdiction in which the vehicle is used or is intended to be used.

Vehicle Standards Bulletin 14 means the *National Code of Practice for Light Vehicle Construction and Modification* published in 2011 by the Commonwealth Department of Infrastructure and Transport (or any Department that succeeds that Department), as amended from time to time.

VIN means the Vehicle Identification Number allocated in accordance with the ADRs (within the meaning of the Light Vehicle Standards Rules).

windscreen means the main front windscreen and does not include any wind deflector or other subsidiary windscreen.