



New South Wales

Road Transport (General) Amendment (Mass, Loading and Access) Regulation 2015

under the

Road Transport Act 2013

His Excellency the Governor, with the advice of the Executive Council, has made the following Regulation under the *Road Transport Act 2013*.

DUNCAN GAY, MLC
Minister for Roads, Maritime and Freight

Explanatory note

The object of this Regulation is to incorporate, with minor amendments, into the *Road Transport (General) Regulation 2013* the provisions of the *Road Transport (Mass, Loading and Access) Regulation 2005*, which is repealed on 1 September 2015 by section 10 (2) of the *Subordinate Legislation Act 1989*.

This Regulation also makes minor, consequential amendments to the *Road Rules 2014* and the *Road Transport (Vehicle Registration) Regulation 2007*.

This Regulation is made under the *Road Transport Act 2013*, including sections 23 (the general regulation-making power), 24 and 195 and clause 7 of Schedule 1.

Road Transport (General) Amendment (Mass, Loading and Access) Regulation 2015

under the

Road Transport Act 2013

1 Name of Regulation

This Regulation is the *Road Transport (General) Amendment (Mass, Loading and Access) Regulation 2015*.

2 Commencement

This Regulation commences on 1 September 2015 and is required to be published on the NSW legislation website.

Schedule 1 Amendment of Road Transport (General) Regulation 2013

[1] **Clause 3 Definitions**

Omit the definitions of *axle group*, *semi-trailer* and *twin steer axle group* from clause 3 (1).

[2] **Clause 3 (1)**

Insert the following in alphabetical order:

axle group means a single axle, tandem axle group, twin steer axle group, tri-axle group or quad-axle group.

quad-axle group means a group of 4 axles, in which the horizontal distance between the centrelines of the outermost axles is more than 3.2 metres but not more than 4.9 metres.

semi-trailer means a trailer that has:

- (a) one axle group or single axle towards the rear, and
- (b) a means of attachment to a prime mover that would result in some of the mass of the trailer's load being imposed on the prime mover.

twin steer axle group means a group of 2 axles:

- (a) with single tyres, and
- (b) fitted to a motor vehicle, and
- (c) connected to the same steering mechanism, and
- (d) the horizontal distance between the centrelines of which is at least 1 metre but not more than 2 metres.

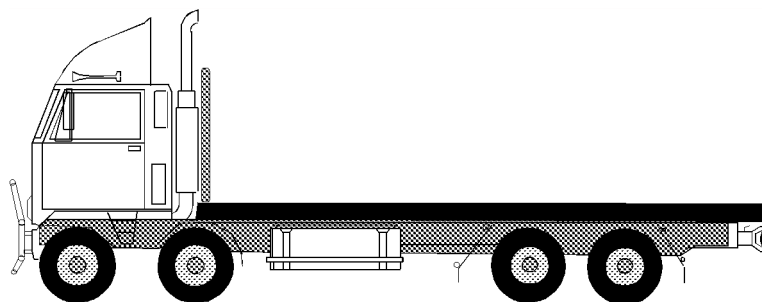

Typical twin steer axle group on a motor vehicle

[3] **Clause 3 (4)**

Insert “and diagrams” after “Notes”.

[4] **Clause 16 Use of crimson flashing warning lights on certain council vehicles**

Omit paragraph (b) of the definition of *excess weight limits legislation* from clause 16 (2).

Insert instead:

- (b) Part 3A and clause 148 of this Regulation.

[5] **Part 3A**

Insert after Part 3:

Part 3A Mass, dimension and load requirements for light vehicles and light combinations

Division 1 Preliminary

50A Application of Part

- (1) This Part applies to a light vehicle or light combination on a road only.
- (2) This Part does not apply to a light vehicle or light combination that is used only on a railway or tramway.

50B Definitions

In this Part:

added load means the moveable load carried by a vehicle.

axle load means the total load, determined in accordance with clause 50U, transmitted to the road by all wheels of a vehicle that are mounted on an axle.

laden mass means the mass of a vehicle and its load borne on the surface on which it is standing or running.

load-carrying, in relation to a vehicle or combination, means a vehicle or combination that is carrying, or is built to carry, a load.

loaded mass means the mass of a vehicle and its added load.

total mass, in relation to a load-carrying vehicle or combination, means the loaded mass of the vehicle or combination and, in relation to a non load-carrying vehicle or combination, means the mass of that vehicle or combination together with:

- (a) all the goods, passengers and drivers in or on the vehicle or combination, and
- (b) all fuel, water, lubricants and readily removable equipment carried in or on the vehicle or combination and required for its normal operation, and
- (c) personal items used by a driver of the vehicle or combination, and
- (d) anything that is normally removed from the vehicle or combination when not in use.

vehicle includes the vehicle's equipment and any substances that the vehicle is carrying that are essential for its operation.

wheel includes a group of wheels that are mounted on an axle and are on one side of the longitudinal centreline of the vehicle.

50C Use of vehicle in contravention of dimension, mass or load restraint requirements

- (1) A person must not drive, or cause to be driven, along a road a light vehicle or light combination that contravenes any of the dimension, mass or load restraint requirements imposed by this Part otherwise than in accordance with a permit issued under clause 50N.

Maximum penalty: 30 penalty units.

- (2) In this clause, **dimension requirement**, **mass requirement** and **load restraint requirement** have the same meanings as in clause 7 of Schedule 1 to the Act.

Division 2 Mass limits for certain motor lorries and certain trailers

50D Definitions

In this Division:

existing motor lorry means a motor lorry for which a New South Wales registration was in force on 1 January 1995 (as long as that registration has continued in force from that day without a break, including continuation by renewal or re-issue of the registration).

visiting motor lorry means a vehicle temporarily in New South Wales that is a motor lorry.

50E Application of Division

- (1) This Division applies to motor lorries (including articulated vehicles), but does not apply to any of the following:
 - (a) a caravan,
 - (b) a station wagon,
 - (c) a trailer, which weighs not more than 250 kilograms when unladen, that is used principally or solely for carrying camping equipment, a boat or other materials used in connection with tours for recreational purposes and that is not used in the course of trade or business,
 - (d) an excavator, road grader, road roller, bulldozer, or other machinery or apparatus, that cannot carry a load (other than any tools, spare parts, fuel, water, oil, or other accessories, used in connection with the vehicle).
- (2) Nothing in this Division authorises a person to drive or use a motor lorry, or cause a motor lorry to be driven or used, in contravention of any provision of the Act or the statutory rules.

50F Mass limit not to be exceeded

- (1) A person must not drive a motor lorry on a road if the total mass of the motor lorry exceeds the lorry's mass limit.
- (2) A person does not contravene this clause if:
 - (a) the motor lorry is driven in accordance with the prior written permission of the Authority and any conditions set out in the document containing the permission, and
 - (b) a copy of that document is carried by the driver of the motor lorry when driving the lorry otherwise than in accordance with subclause (1).

50G Mass limits to be marked on motor lorries over 2 tonnes (except trailers)

- (1) A person must not drive a motor lorry on a road unless the lorry is marked in accordance with this clause. However, this clause does not apply to a lorry that has an unladen mass of 2 tonnes or less or that is a trailer.
Maximum penalty: 20 penalty units.
- (2) A motor lorry (except a motor lorry to which subclause (3) or (4) applies) is marked in accordance with this clause if:
 - (a) the word "Tare" or the letter "T", followed by the unladen mass (in kilograms) of the lorry, is displayed on the right hand side or off-side of the lorry, and

- (b) there are displayed immediately under that matter the words “gross vehicle mass” or letters “GVM” (or, in the case of an articulated vehicle, the words “gross combination mass” or letters “GCM”) followed by the mass limit in kilograms that applies to the lorry, and
 - (c) the displayed matter is displayed in numerals, and block letters, at least 50 millimetres high, and clearly legible at a distance of 5 metres.
- (3) An existing motor lorry (except one for which a mass limit has been determined under clause 50J) is marked in accordance with this clause if:
- (a) the word “Tare” or the letter “T”, followed by the unladen mass (in kilograms) of the lorry, is displayed on the right hand side or off-side of the lorry, and
 - (b) the word “Aggregate” or the letter “A” is displayed immediately under that matter, followed by the mass limit in kilograms that applies to the lorry, and
 - (c) the displayed matter is displayed in numerals, and block letters, at least 50 millimetres high, and clearly legible at a distance of 5 metres.
- (4) A visiting motor lorry is marked in accordance with this clause if its tare mass and maximum laden mass are displayed in accordance with the law for the time being in force in the State or Territory where the lorry is registered.

50H Mass limits for motor lorries (except existing motor lorries)

- (1) For the purposes of this Division, the *mass limit* of a motor lorry (except an existing motor lorry) is:
- (a) in the case of an articulated vehicle—the GCM of the motor lorry, and
 - (b) in any other case—the GVM of the motor lorry.
- (2) For the purposes of subclause (1), the GCM or GVM of a motor lorry that has not been altered since manufacture is the mass recorded for that type of motor lorry by the Authority as the GCM or GVM, respectively.
- (3) However, if the Authority has not recorded a GCM for a type of motor lorry that is an articulated vehicle, but the Authority has recorded a GVM for its type of prime mover as a standard table top motor lorry, for the purposes of subclause (1) the GCM of the articulated vehicle (if unaltered since manufacture) is 1.67 times the GVM recorded for that type of standard table top motor lorry.
- (4) In the case of a motor lorry (except an existing motor lorry) that has been altered since manufacture or that has not been altered since manufacture but to which no mass limit applies under subclause (2) or (3), the mass limit of the lorry is that determined under clause 50J (or, in the case of a visiting motor lorry, in accordance with the law for the time being in force in the State or Territory where the lorry is registered).

50I Mass limits for existing motor lorries

- (1) For the purposes of this Division, the *mass limit* of an existing motor lorry is its aggregate weight, taken as the aggregate weight that was in force for the lorry immediately before 1 January 1995 under Regulation 120A of the *Motor Traffic Regulations 1935* (as in force immediately before that date).
- (2) However, if since that aggregate weight was determined, the lorry has been altered (whether before, on or after 1 January 1995), the mass limit of the lorry is to be the mass limit determined under clause 50J.

50J Determination of different mass limits

- (1) The Authority may determine a mass limit for a motor lorry (except a visiting motor lorry):
 - (a) if the lorry is not an existing motor lorry and no mass limit applies to the lorry under clause 50H (2) or (3), or
 - (b) if the lorry is an existing motor lorry and has been altered as referred to in clause 50I (2), or
 - (c) if the mass limit of the motor lorry applying under an earlier determination under this clause is no longer in accordance with the safe working limits of the motor lorry (for example, if the lorry has been altered since that determination was made), or
 - (d) on application by the owner of the motor lorry if the Authority is satisfied that the safe loading limits of the motor lorry have been altered.
- (2) A determination under this clause must be based on the construction and componentry of the lorry.
- (3) The Authority must notify the owner of a motor lorry of any determination made in respect of the lorry or any refusal by the Authority of an application by the owner under subclause (1) (d).
- (4) A determination under this clause takes effect when notice of it is served by the Authority on the owner of the motor lorry or from a later date specified in the notice.

50K Authority may require information or certificate

- (1) The Authority may, by written notice to the owner of a motor lorry, require the owner to provide the Authority within a period specified in the notice with the information in respect of the motor lorry or its equipment that is specified in the notice.
- (2) If the Authority determines a mass limit for a motor lorry under clause 50J, it may require the owner of the lorry to forward to the Authority the certificate of registration of the lorry for endorsement (or cancellation and re-issue) under this clause.
- (3) The Authority may endorse on a certificate of registration of a motor lorry (or cancel and re-issue a certificate with) a mass limit determined by the Authority under clause 50J. The Authority is to forward the certificate to the owner once it has so endorsed or re-issued it.
- (4) An owner of a motor lorry must not fail to comply with a requirement under this clause without reasonable excuse.
Maximum penalty: 20 penalty units.

Division 3 Dimension requirements

50L Projection of loading or equipment of vehicles

- (1) A person must not drive on a road:
 - (a) a motor vehicle (not being a motor bike or a mobile crane that is 9.5 metres or less in length) if the loading or equipment on the vehicle or any trailer drawn by the vehicle:
 - (i) projects more than 1.2 metres in front of the headlights of the motor vehicle if the motor vehicle is not a mobile crane, or

- (ii) projects more than 3.5 metres in front of the steering wheel of the motor vehicle if the motor vehicle is a mobile crane, or
 - (iii) in the case of a vehicle not exceeding 9.5 metres in length or a trailer, projects more than 1.2 metres to the rear of the motor vehicle or trailer, except as provided by subclause (2), or
 - (iv) in the case of a vehicle exceeding 9.5 metres in length, projects to the rear of the vehicle beyond a point that is 4 metres from the rear overhang line, or
 - (v) projects more than 150 millimetres beyond the extreme outer portion of either side of the vehicle or trailer, but nothing in this subparagraph applies to any rear vision mirror, signalling device, side mounted lamp or tyre pressure monitoring system permitted by the *Road Transport (Vehicle Registration) Regulation 2007* to be fitted to the vehicle, or
- (b) a motor bike without a sidecar attached if any loading or equipment on the motor bike projects more than 150 millimetres in front of the outer extremity of the front wheel or more than 300 millimetres behind the outer extremity of the rear wheel or the loading projects beyond the extreme outer portion of the cycle on either side, or
- (c) a motor bike with a sidecar attached if:
- (i) any part of the vehicle or its loading or equipment projects more than 600 millimetres in front of the outer extremity of the front wheel or more than 900 millimetres behind the outer extremity of the rear wheel of the motor bike, or
 - (ii) the loading projects beyond the extreme outer portion of the vehicle on either side, or
- (d) an articulated vehicle first registered on or after 1 January 1960, not being a vehicle to which a pole-type trailer is attached, if any part of the semi-trailer or its loading or equipment projects more than 1.9 metres radially forward of the axis of the pivot pin, or
- (e) an articulated vehicle that exceeds 19 metres in length, or
- (f) a motor vehicle and trailer combination that exceeds 19 metres in length.
- (2) It is not a contravention of subclause (1) (a) (iii) for any loading or equipment to project more than 1.2 metres to the rear of a motor vehicle or any trailer drawn by the vehicle if:
- (a) the overall length of the vehicle or of the combination of vehicle and trailer, together with the loading or equipment on it, is within the relevant limit fixed by Schedule 2 to the *Road Transport (Vehicle Registration) Regulation 2007*, and
 - (b) there is carried at the extreme rear of the loading or equipment a red flag or other suitable object, in either case not less than 300 millimetres square, and the flag or object is kept clearly visible as a warning to persons on the roadway in the near vicinity of the vehicle or trailer, and
 - (c) between the hours of sunset and sunrise or when there is insufficient daylight to render a person dressed in dark clothing clearly discernible at a distance of 100 metres, there is affixed at the extreme rear of the loading or equipment:
 - (i) a lighted lamp showing a clear red light to the rear, visible under normal atmospheric conditions at a distance of 200 metres, or

- (ii) not less than two reflectors capable of projecting a red reflection of light from the light of any following vehicle.
- (3) For the purpose of subclauses (1) (a) (iii) and (2), *equipment* includes the pole of a pole-type trailer.
- (4) If any portion of the loading or equipment of a motor vehicle or of any trailer drawn by the vehicle projects in a manner so that it would not be readily visible to any person following immediately behind the vehicle, the driver of the vehicle must:
 - (a) by means of a red flag or other suitable object, in either case not less than 300 millimetres square, mark the end of the loading or equipment so that it may be clearly visible to persons in its vicinity, and
 - (b) between the hours of sunset and sunrise or when there is insufficient daylight to render a person dressed in dark clothing discernible at a distance of 100 metres, cause to be attached to the extreme rear of the loading or equipment a lighted lamp or reflectors as referred to in subclause (2) (c).
- (5) In this clause:
centre of an axle group means:
 - (a) a line located midway between the centrelines of the outermost axles of the group, or
 - (b) if the group consists of 2 axles, one of which is fitted with twice the number of tyres as the other axle—a line located one third of the way from the centreline of the axle with more tyres towards the centreline of the axle with fewer tyres.

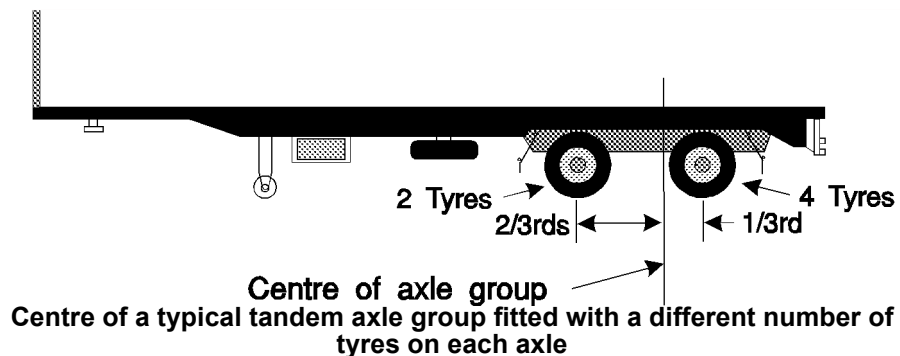
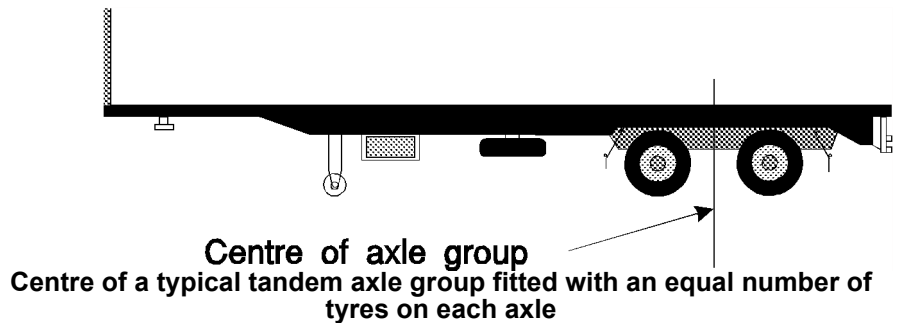

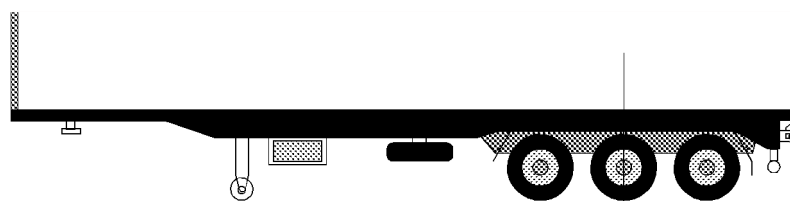

Centre of axle group
Centre of a typical tri-axle group

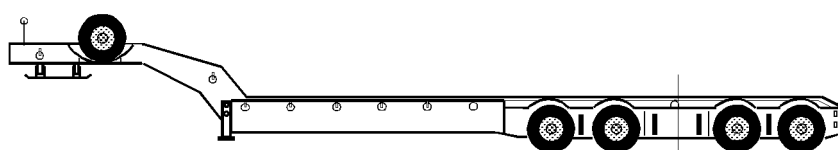

Centre of axle group
Centre of a typical quad axle group

pole-type trailer means a trailer that:

- (a) is attached to a towing vehicle by means of a pole or an attachment fitted to a pole, and
- (b) is ordinarily used for transporting loads, such as logs, pipes, structural members or other long objects, that are generally capable of supporting themselves like beams between supports.

Note. A pole-type trailer is also known as a jinker.

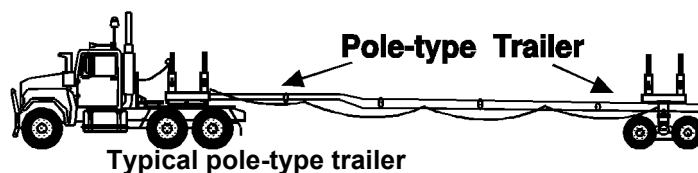

rear overhang line means:

- (a) if there is a single axle at the rear of the vehicle—the centreline of the axle, or
- (b) if there is an axle group at the rear of the vehicle—the centre of the axle group, determined without regard to the presence of any steerable axle or retractable axle in the group unless all axles in the group are steerable or retractable.

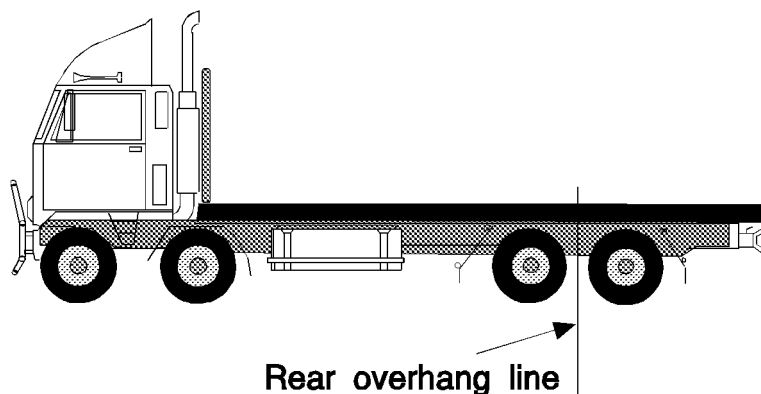

Rear overhang line on a typical motor vehicle that has an axle group

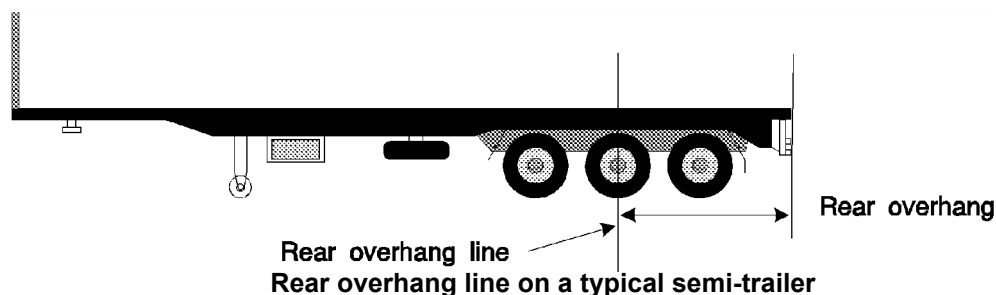

retractable axle means an axle that can be raised so that the tyres on the axle do not touch the ground.

50M Exemption by notice in Gazette

- (1) The Authority may, by notice published in the Gazette, exempt a person or class of persons from the operation of any of the provisions of clause 50L (1).
- (2) The notice must specify:
 - (a) the conditions (if any) of the exemption, and
 - (b) how long it is to remain in force.

50N Exemption by permit

- (1) The Authority may, on application by a person, issue a permit exempting the person from the operation of any of the provisions of clause 50L (1).
- (2) An application for a permit must:
 - (a) be in writing and in a form approved by the Authority, and
 - (b) be accompanied by the fee specified in Schedule 1.
- (3) The permit must set out the conditions (if any) of the exemption.

- (4) The Authority may waive or refund payment of all or part of a fee payable under this clause, if the Authority considers it appropriate to do so.

Division 4 Other mass and dimension requirements

50O Special mass limits

- (1) In a special case, or where the provisions of this Part do not apply to a vehicle, a roads authority may fix a maximum axle load, maximum loaded mass or other load limit for the vehicle.
- (2) A load or limit must be:
- (a) notified in writing to the owner of the vehicle to which it applies, or
 - (b) published in the Gazette or in a local newspaper circulated in the locality to which the limit applies.
- (3) A limitation referred to in subclause (2) is taken to be imposed by this Part.
- (4) A person must not fail to comply with the terms of a notification issued under this clause.

50P Mass limits for three-wheeled vehicles

A person must not drive a three-wheeled motor vehicle on a road if the mass of the load of the vehicle exceeds the mass that the vehicle is capable of carrying as stated in the certificate of registration for the vehicle.

Maximum penalty: 20 penalty units.

50Q Lower limit to apply if multiple mass requirements

If more than one mass limit applies to a vehicle or combination, or part of a vehicle or combination, the lower mass limit must be complied with.

50R Load requirements

- (1) A load on a vehicle or a trailer must not be placed in a way that makes the vehicle unstable or unsafe.
- (2) A load on a vehicle or a trailer must be secured so that it is unlikely to fall or be dislodged from the vehicle.
- (3) An appropriate method must be used to restrain the load on a vehicle.
- (4) In proceedings for a contravention of a requirement under this clause, it is sufficient for the prosecution to prove that the load on the vehicle was not placed, secured or restrained (as the case requires) in a way that met the performance standards recommended in the *Load Restraint Guide: Guidelines and Performance Standards for the Safe Carriage of Loads on Road Vehicles, Second Edition*, published by the National Transport Commission and in force from time to time (the **Load Restraint Guide**).
- Note.** The Load Restraint Guide is available on the National Transport Commission's website (www.ntc.gov.au).
- (5) In proceedings for a failure to comply with this clause, a document purporting to be the Load Restraint Guide is taken to be the Load Restraint Guide, unless the document is proved by the defendant not to be the Load Restraint Guide.
- (6) If the prosecution in proceedings for a contravention of a requirement under subclause (2) proves that the load, or part of the load, had fallen off the vehicle, the burden of proof is on the defendant to show compliance.

50S Driver to have sufficient control

A person must not drive a motor vehicle on a road:

- (a) if the vehicle is constructed, equipped or loaded, or if anything is attached to the vehicle, in a manner that prevents the driver from having a view of traffic on either side of the vehicle and in all directions in front of the vehicle that enables the driver to drive the vehicle safely, or
- (b) if the vehicle is a motor bike that is constructed, equipped or loaded, or if anything is attached to the motor bike, in a manner that prevents the driver from having a view of the approach of any overtaking vehicle, or
- (c) if the person is prevented from safely driving or controlling the motor vehicle or any trailer or other vehicle attached to the motor vehicle because of the weight or dimensions of the loading or equipment of the towing vehicle or trailer or other towed vehicle or the manner in which the loading or equipment is placed on or attached to the towing vehicle or trailer or other towed vehicle.

Maximum penalty: 20 penalty units.

Division 5 Checking and measuring procedures

50T Method of determining wheel loads

- (1) For the purpose of determining the wheel load of a wheel of a motor vehicle or a trailer, the wheel is to be weighed (alone or together with any other wheel or wheels forming an axle group of which the wheel the weight of which is being determined forms part) in such a way that the wheel or wheels are weighed together with the portion of the vehicle and load supported by the wheel or wheels.
- (2) If the wheel load of a wheel is determined under subclause (1) by weighing the wheel with other wheels, the load of the wheel the load of which is being determined is the mass of all the wheels so weighed divided by the number of wheels so weighed.
- (3) In this Division, *wheel load* means the mass transmitted to the road by a wheel.

50U Method of determining axle loads

For the purpose of determining the axle load of an axle or axle group of a motor vehicle or trailer, either of the following methods may be used:

- (a) the wheel loads of all wheels on the axle or in the axle group may be added together,
- (b) if the mass of the vehicle together with any load that it supports is known—the axle loads of all single axles and all the axle groups other than the axle or group the load of which is being determined are to be subtracted from that mass.

50V Method of determining total mass

For the purpose of determining the total mass of a vehicle or combination, either of the following methods may be used:

- (a) the axle loads of all the single axles and all the axle groups of the vehicle or combination may be added together,
- (b) all the wheels of the vehicle or combination, together with the vehicle and any added load supported by the wheels, may be weighed simultaneously on a weighing device or weighing devices.

50W Weighing devices

If a weighing device being used for the purpose of determining a wheel load, an axle load or a total mass in accordance with this Part shows a mass in excess of the weight for which the weighing device has been verified under the *National Measurement Act 1960* of the Commonwealth, the load on the weighing device when so used is, for the purposes of this Part, taken to be the weight for which the weighing device has been so verified.

Division 6 Miscellaneous

50X Keeping documents

- (1) The driver of a vehicle or a combination must carry in the driving compartment:
 - (a) a copy of any notice or permit given under this Part under which the vehicle or the combination is operating, or
 - (b) an information sheet issued by the Authority setting out the obligations imposed under the notice.Maximum penalty: 30 penalty units.
- (2) Subclause (1) does not apply if the notice or permit states that the subclause does not apply.
- (3) In this clause, *information sheet* means advice published or adopted by the Authority, and available on request from the Authority.

50Y Exemptions in emergencies

- (1) In an emergency such as a fire, explosion or natural disaster (including a drought), the Authority may exempt a vehicle or combination, or its driver or owner, from a requirement of this Part if:
 - (a) the vehicle or combination is being used, or is intended to be used, to protect life or property, to restore communication or the supply of energy, water or services such as sewage disposal or to provide drought relief, and
 - (b) the exemption does not present an unreasonable danger to other road users.
- (2) An exemption may be subject to conditions imposed by the Authority.
- (3) The Authority must make a written record of the exemption, and any conditions of the exemption, but may cause it to be communicated orally to the owner or driver.

[6] Clause 148

Insert after clause 147:

148 Mass requirements on certain roads and bridges

- (1) The council of a local government area or the Authority may do any of the following things by means of a notice (a *limit notice*) conspicuously displayed on or adjacent to the road, bridge or road-ferry concerned:
 - (a) prohibit vehicles with a laden mass exceeding a specified maximum mass from passing along or over a road, bridge or causeway,
 - (b) prohibit vehicles with a laden mass exceeding a specified maximum mass from using a road-ferry maintained in connection with a road.

- (2) A limit notice must:
 - (a) display the words “BRIDGE LOAD LIMIT” or “ROAD LOAD LIMIT”, or
 - (b) be in or similar to a sign approved by the Authority for the purposes of this clause.
- (3) A limit notice that displays the words “BRIDGE LOAD LIMIT” or “ROAD LOAD LIMIT” prohibits the passage, from a direction facing the notice, of a vehicle or combination if:
 - (a) the total mass of the vehicle or combination exceeds the gross mass indicated by the notice, or
 - (b) the mass carried by an axle or axle group of the vehicle or combination exceeds the mass indicated by the notice for that kind of axle or axle group.
- (4) A limit notice in or similar to a sign approved by the Authority for the purposes of this clause prohibits the passage, from a direction facing the notice, of a vehicle or combination exceeding the total mass indicated by the notice.
- (5) The powers conferred by this clause may only be exercised with respect to classified roads by the Authority.
- (6) A person who fails to comply with the terms of a limit notice is guilty of an offence.
Maximum penalty: 30 penalty units.
- (7) In an emergency such as a fire, explosion or natural disaster (including a drought), the Authority may exempt a vehicle or combination, or its driver or owner, from a prohibition referred to in this clause if the circumstances referred to in clause 50Y (1) (a) and (b) apply. Clause 50Y (2) and (3) apply to such an exemption.
- (8) In this clause:
 - (a) *bridge* and *classified road* have the same meanings as in the *Roads Act 1993*, and
 - (b) *laden mass*, *total mass* and *vehicle* have the same meanings as in Part 3A of this Regulation.

[7] Schedule 1 Fees

Omit the source reference.

[8] Schedule 1

Insert the following after item 2:

2A Application for a permit under clause 50N clause 50N (2) (b) 70

[9] Schedule 5 Penalty notice offences

Insert the following in appropriate order in the matter relating to the *Road Transport (General) Regulation 2013* in Columns 1, 2 and 3 respectively:

Clause 50C (in respect of a contravention of a requirement of clause 50F (1) or 50R) Class 1, 2, 6, 7, 12, 14 Level 9

Clause 50C (in respect of a contravention of a requirement of clause 50L) Class 1, 2, 6, 7, 12, 14 Level 3

Clause 50G (1)	Class 1, 2, 6, 7, 12, 14	Level 2
Clause 50K (4)	Class 1, 2	Level 4
Clause 50P	Class 1, 2	Level 4
Clause 50S (a); Clause 50S (b)	Class 1, 2, 12, 14	Level 4
Clause 50S (c)	Class 1, 2, 12, 14	Level 6
Clause 50X (1)	Class 1, 2, 6, 7, 12, 14	Level 3
Clause 148, if the offence arises because the laden mass of the vehicle exceeds the maximum specified by the limit notice:		
(a) by not more than 1 tonne	Class 1, 2, 12, 14	Level 5
(b) by more than 1 tonne but not more than 2 tonnes	Class 1, 2, 12, 14	Level 8
(c) by more than 2 tonnes but not more than 3 tonnes	Class 1, 2, 12, 14	Level 10
(d) by more than 3 tonne but not more than 4 tonnes	Class 1, 2, 12, 14	Level 11

[10] Schedule 5

Omit the matter relating to the *Road Transport (Mass, Loading and Access) Regulation 2005*.

[11] Schedule 6 Savings and transitional provisions

Insert after clause 4:

5 Road Transport (Mass, Loading and Access) Regulation 2005—savings

Any act, matter or thing that, immediately before the repeal of the *Road Transport (Mass, Loading and Access) Regulation 2005*, had effect under a provision of that Regulation continues to have effect under any provision of this Regulation that corresponds (or substantially corresponds) with the provision of the repealed Regulation.

Schedule 2 Amendment of other road transport legislation

2.1 Road Rules 2014

[1] Rule 221–1 NSW rule: using crimson flashing warning lights on certain local council vehicles

Omit paragraph (b) of the definition of *excess weight limits legislation* from rule 221–1 (2).

Insert instead:

- (b) Part 3A and clause 148 of the *Road Transport (General) Regulation 2013*.

[2] Dictionary

Omit paragraph (c) of the definition of *oversize vehicle*.

2.2 Road Transport (Vehicle Registration) Regulation 2007

[1] Clause 90 Application of Part 3A and clause 148 of Road Transport (General) Regulation 2013

Omit “the *Road Transport (Mass, Loading and Access) Regulation 2005* or a provision of a regulation that replaces that regulation” from clause 90 (1).

Insert instead “Part 3A or clause 148 of the *Road Transport (General) Regulation 2013*”.

[2] Clause 90 (2)

Omit the subclause.

[3] Schedule 2 Vehicle standards

Omit “the *Road Transport (Mass, Loading and Access) Regulation 2005* (or any regulation that replaces that regulation)” from clause 124 (10).

Insert instead “Part 3A or clause 148 of the *Road Transport (General) Regulation 2013*”.

[4] Schedule 2, clause 124 (11) (b)

Omit the paragraph. Insert instead:

- (b) Part 3A and clause 148 of the *Road Transport (General) Regulation 2013*.