



New South Wales

Fair Trading Amendment (Prams and Strollers) Regulation 2008

under the

Fair Trading Act 1987

Her Excellency the Governor, with the advice of the Executive Council, has made the following Regulation under the *Fair Trading Act 1987*.

LINDA BURNEY, M.P.,
Minister for Fair Trading

Explanatory note

The object of this Regulation is to amend the *Fair Trading Regulation 2007* to prescribe a product safety standard for prams and strollers.

The product safety standard prescribed is that prams and strollers must comply with certain provisions of the Australian/New Zealand Standard entitled AS/NZS 2088:2000, *Prams and Strollers—Safety requirements*.

This Regulation is made under the *Fair Trading Act 1987*, including sections 26 and 92 (the general regulation-making power).

2008 No 180

Clause 1 Fair Trading Amendment (Prams and Strollers) Regulation 2008

Fair Trading Amendment (Prams and Strollers) Regulation 2008

under the

Fair Trading Act 1987

1 Name of Regulation

This Regulation is the *Fair Trading Amendment (Prams and Strollers) Regulation 2008*.

2 Commencement

This Regulation commences on 1 July 2008.

3 Amendment of Fair Trading Regulation 2007

The *Fair Trading Regulation 2007* is amended as set out in Schedule 1.

Schedule 1 Amendment

(Clause 3)

Part 2, Division 15A

Insert after Division 15:

Division 15A Prams and strollers

52A Definitions

In this Division:

AS/NZS 2088 means the Australian/New Zealand Standard entitled AS/NZS 2088:2000, *Prams and Strollers—Safety requirements* published jointly by Standards Australia and Standards New Zealand on 15 December 2000.

pram means a wheeled vehicle with a body of box-like or boat-like shape designed to transport a baby or child weighing up to and including 9 kilograms primarily in a fully reclined position.

stroller means a wheeled vehicle designed to transport a child in a seated position, and which may also be adjusted to a semi-reclined position or fully reclined position.

52B Safety standard

The product safety standard prescribed for a pram or stroller is that they must comply with AS/NZS 2088.

52C Variation of AS/NZS 2088

For the purposes of this Division, AS/NZS 2088 is taken to have been amended as follows:

- (a) by omitting from clause 1 “This standard specifies materials, construction, performance and labelling requirements for prams and strollers, and includes a dimensional requirement for the depth of a pram.” and by inserting instead “This Standard specifies safety requirements for prams and strollers.”,
- (b) by omitting clauses 2, 3, 5, 6, 7.1–7.5, 7.7, 7.8.1.1 (b)–(d), 7.8.1.2, 7.9, 8.1–8.4, 8.6.1, 8.8–8.10, 9 and 10,
- (c) by omitting from clause 7.6 “(See Note to clause 7.5.)”,

2008 No 180

Fair Trading Amendment (Prams and Strollers) Regulation 2008

Schedule 1 Amendment

- (d) by inserting at the end of clause 7.6 the following:

The colour of the parking device actuator shall be red. The surrounding frame work and mouldings shall be a contrasting colour.
- (e) by omitting from clause 7.8.1.1 (a) “, comprising shoulder, waist and crotch straps. An example is shown in Figure 3.” and by inserting instead “that includes waist and crotch straps.”,
- (f) by omitting from clause 7.8.1.1 (e) “Items (a) and (b)” and by inserting instead “Item (a)”,
- (g) by omitting Figure 3 from clause 7.8.1.1,
- (h) by omitting from clause 7.8.1.3 “at a point where the seat cannot be pulled away from the frame of the stroller by pulling the restraint straps”,
- (i) by inserting before clause 8:

7.10 Tether strap

Vehicles shall be provided with a suitable strap to allow the vehicle to be tethered to the vehicle operator while it is in use.

The tether strap shall be designed to reduce the possibility of it being a strangulation hazard for infants inside or outside the vehicle.

The length of the strap is to be as short as practical and any loop in the strap shall have a perimeter of less than 360 mm.

- (j) by omitting from clause 8.6.2 (a) “(See also Note to Clause 7.9.)”,
- (k) by inserting at the end of clause 8.6.2 (a) the following:

When tested in accordance with the following procedures, the test ball shall not fall out of the seat unit:

Recline the backrest of the seat unit to the most reclined position. Attach, according to the manufacturer’s instructions, the textile parts intended to retain the child (including the rear part of the hood and aprons).

Fix the vehicle to a plane inclined at 45° with respect to the horizontal and 15° with respect to the perpendicular direction of the longitudinal axis considered when inclining the plane to 45°. The vehicle shall be placed along the longitudinal axis of the plane.

Place a test ball comprising of a sphere with a hard smooth surface of diameter 120 mm (±2 mm) and 5 kg (±0.1 kg) weight on the centre of the junction of the seat and backrest of the vehicle and let the ball roll freely. Record whether the test ball falls out of the seat unit.

Repeat the procedure but with the inclination of the plane of 15° to the opposite side of the longitudinal axis.

Repeat the procedure without inclining the plane at 15° but simply reclined at 45°.

- (l) by inserting after clause 8.6.2 (b) (ii) the following:
 - (iii) When tested in accordance with the following procedures, if the small torso probe passes through the gap between the handle and the body of the pram or stroller, the large head probe shall also pass through.

The probes used in this test are made of hard smooth material fitted with suitable handgrips, comprising the following:

- (a) a small torso probe with dimensions as shown in Figure A below:

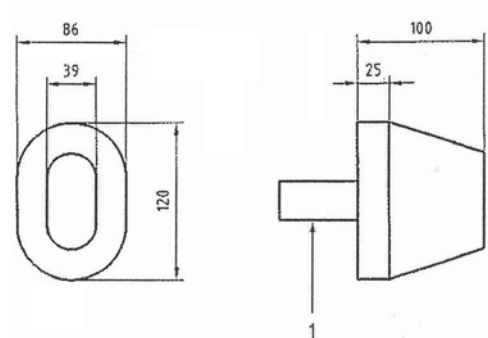

Notes to Figure A: Dimensions are in mm; 1 is the hand grip

2008 No 180

Fair Trading Amendment (Prams and Strollers) Regulation 2008

Schedule 1 Amendment

- (b) a large head probe in the shape of a cylinder of diameter 223 mm and length 100 mm, with a handgrip fitted to an end of the cylinder (these probes have dimensional tolerances of 2 mm).

Check whether the small torso probe can pass through the gap between the handle and the end of the pram/stroller body applying force of 90 N.

Check if the large head probe passes through the opening when pushed along the axis of the handgrip, with a force not exceeding 5 N.

- (m) by inserting after clause 11.1 (e) the following:
- (f) A notice placed on the tether strap, as follows:
WARNING: USE THIS STRAP TO STOP THE PRAM/STROLLER* ROLLING AWAY.
- (n) by omitting clause 11.2 and by inserting instead the following:
- 11.2 Legibility of marking**
The wording shall be clearly legible and the marking specified in clauses 11.1 (c), (d), (e) and (f) shall be characters not less than 2.5 mm high.
- (o) by omitting Appendices B—H, K and O—Q.

BY AUTHORITY
